

TRACTOR -- MODEL NUMBER BI12970A

ELECTRICAL

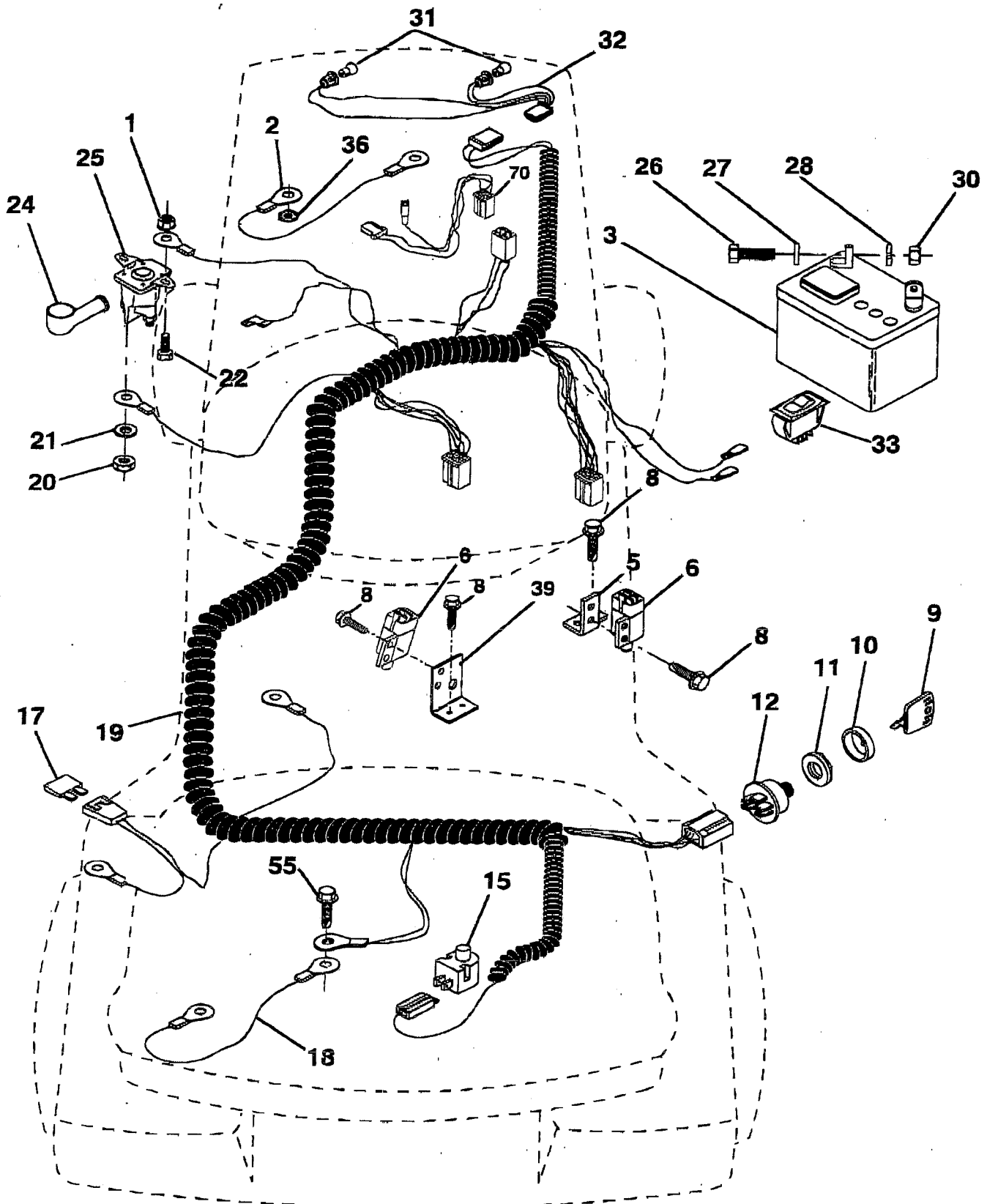

TRACTOR -- MODEL NUMBER BI12970A**ELECTRICAL**

KEY NO.	PART NO.	DESCRIPTION
1	73640400	Nut, Hex, Keps 1/4-20 UNC
2	108423X	Assembly, Cable
3	144924	Battery
5	108236X	Bracket, Switch
6	109553X	Switch, Interlock (4 Term)
8	17021008	Screw, Hex Head, Tapping #10-24 x 1/2
9	140401	Key, Molded
10	141226	Cover, Key, Ignition
11	140400	Nut, Ignition
12	144921	Switch, Ignition
15	121305X	Switch, Plunger
17	108824X	Fuse
18	128353	Assembly, Cable
19	146064	Harness, Ignition
20	73350400	Nut, Hex, Jam 1/4-20
21	10090400	Washer, Lock 1/4
22	71110408	Bolt, Hex 1/4-20 x 12 Grade 5
24	131563	Cover, Terminal
25	145673	Solenoid
26	74760412	Bolt, Hex Head 1/4-20 UNC x 3/4
27	19091016	Washer 9/32 x 5/8 x 16 Gauge
28	10040400	Washer, Lock, Hvy. Hel. Spring 1/4
30	73220400	Nut, Hex, Fin 1/4-20
31	4152J	Bulb Light
32	136850	Harness Asm Light
33	110712X	Switch Light
36	11150400	Washer, Lock Int. Tooth 1/4
39	141735	Bracket Switch Clutch
55	17490508	Screw Thdrol 5/16 - 18 x 1/2
70	140413	Harness, Engine

NOTE: All component dimensions given in U.S. inches
1 inch = 25.4 mm

REPAIR PARTS

TRACTOR - - MODEL NUMBER BI12970A

HOOD

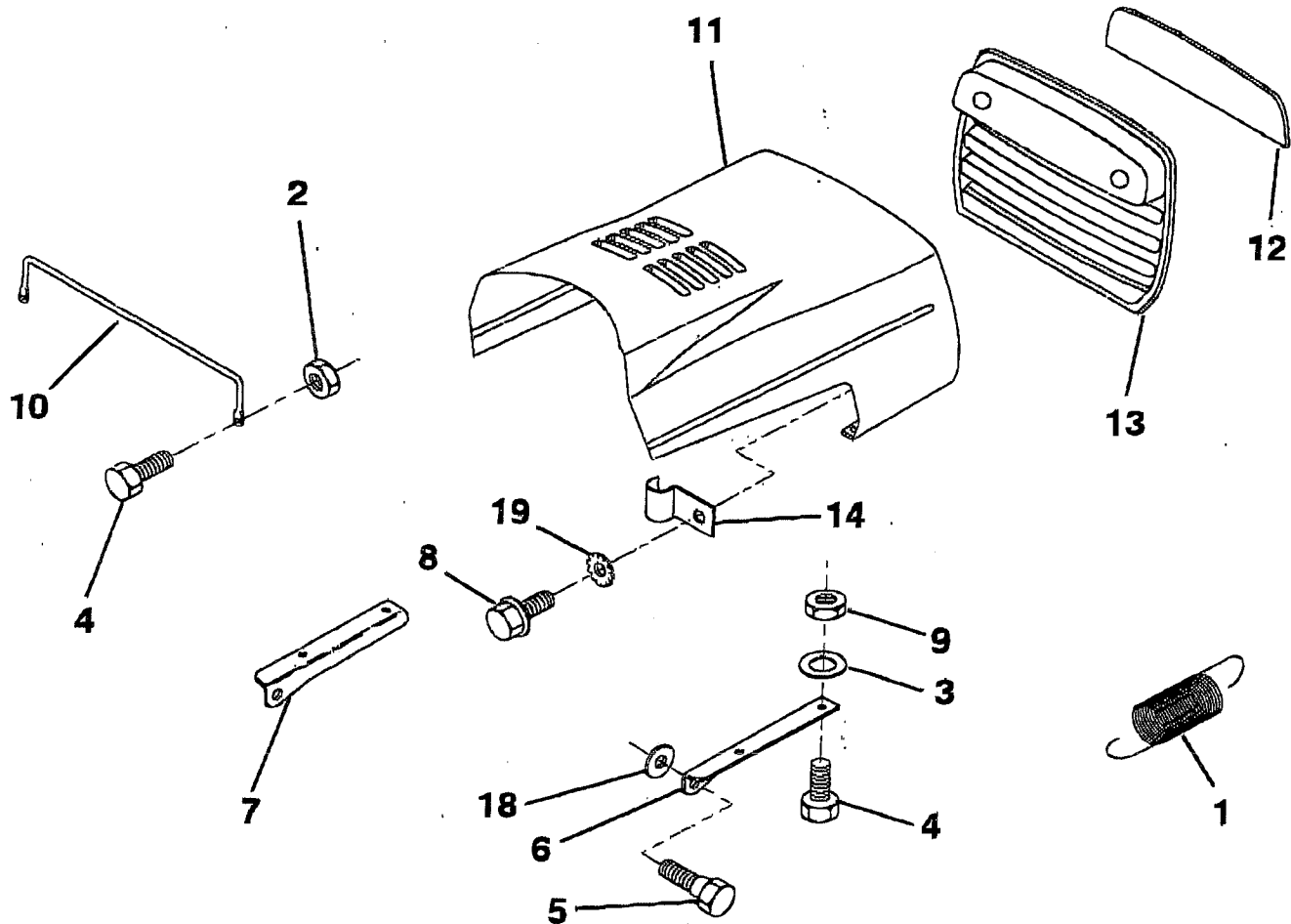

KEY NO.	PART NO.	DESCRIPTION
1	124657X	Bolt Hex 1/4 - 20 x 3/4
2	73640400	Nut, Keps, Hex
3	18091416	Support, Pivot, Hood
4	74780412	Washer 9/32 x 5/8 x 16 Ga.
5	139888	Bolt, Shoulder
6	122549X	Bracket, Hood, Rh
7	122548X	Bracket, Hood, Lh
8	17521312	Nut Lock w/Ins. 1/4 - 20 INC
9	73800400	Duct, Air

KEY NO.	PART NO.	DESCRIPTION
10	123693X	Bracket, Hood
11	132918X520	Hood
12	122035X	Lens
13	127029X	Grill
14	2751R	Clip Line Fuel 13/32 Mtg Hole
18	19111116	Washer 11/32 x 11/16 x 16 Ga.
19	11030400	Washer Lock 1.4 Int./Ext. Tooth

NOTE: All component dimensions given in U.S. inches
1 inch = 25.4 mm

TRACTOR -- MODEL NUMBER BI12970A

FENDER / CHASSIS

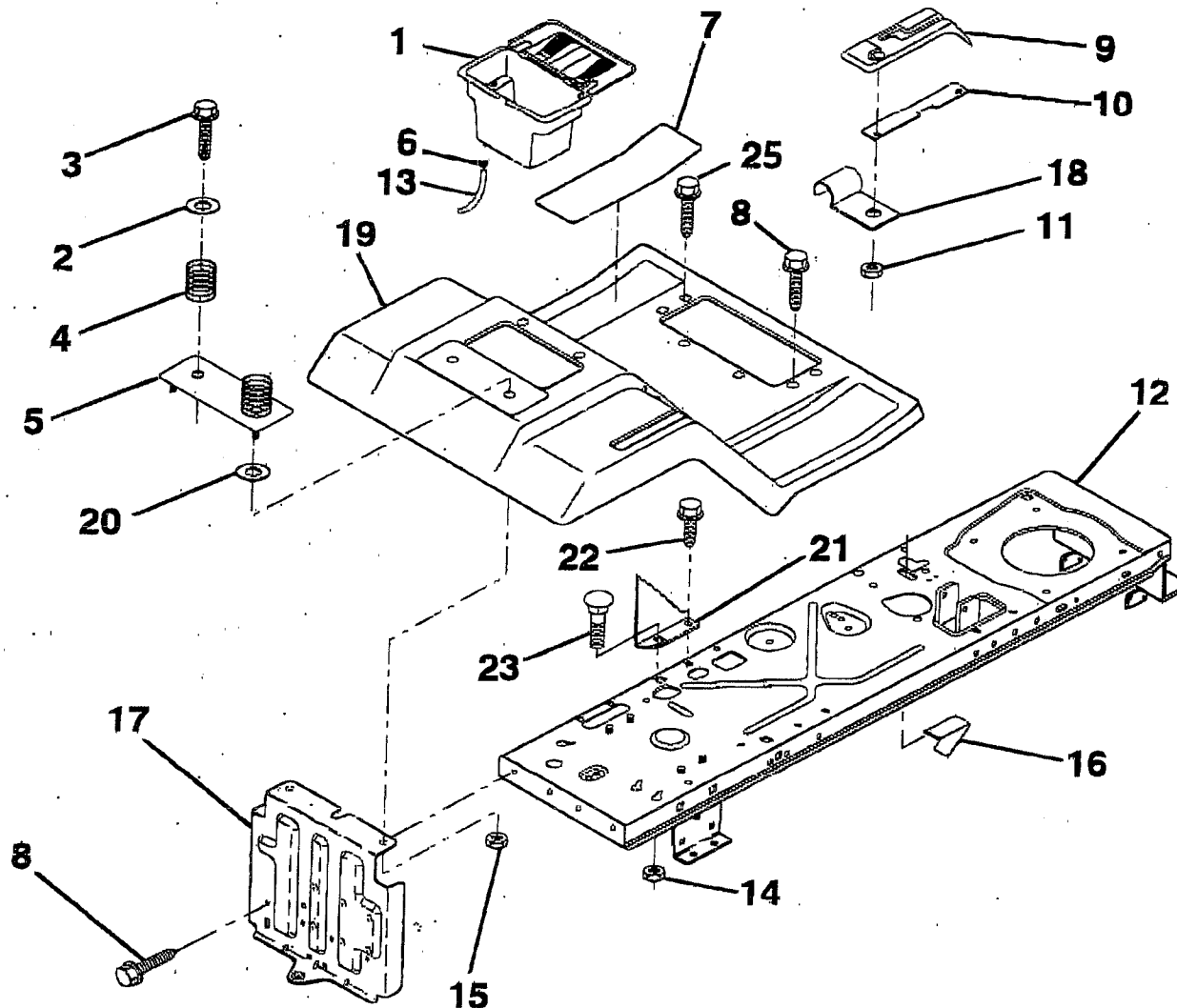

KEY NO.	PART NO.	DESCRIPTION
1	129965	Case, Battery
2	19132012	Washer 13/32 x 1-1/4 x 12 Ga.
3	17490612	Screw, Hex Washer Head, Thdrol 3/8 - 16 x 3/4
4	124181X	Spring, Compression, Seat
5	127115X520	Plate, Fender
6	109596X	Clamp, Hose
7	124144X	Pad, Footrest
8	17490512	Screw, Hex Washer Head, Thdrl 5/16 - 18 x 3/4
9	126985X	Console, Shift Control
10	139783	Bar, Shift Lock
11	124346X	Nut, Self-Threading 3/16
12	145190	Chassis, Assembly, Weldment
13	109238X	Tube, Battery Drain

KEY NO.	PART NO.	DESCRIPTION
14	73680500	Nut, Crownlock 5/16 - 18.
15	73640400	Nut, Hex Keps 1/4 - 20
16	141736	Switch Actuator
17	140782	Drawbar
18	126470X	Clip, Insulated
19	140956X520	Fender/Footrest
20	19091413	Washer 9/32 x 7/8 x 13 Ga.
21	140297	Bracket, Depth Stop
22	17490508	Screw, Thdrl 5/16 - 18 x 1/2
23	72110506	Bolt, Carriage 5/16 - 18 x 3/4
25	17190516	Screw Hex Wsh Hd, Thdrol 5/16-18 x 1

NOTE: All component dimensions given in U.S. inches
1 inch = 25.4 mm

REPAIR PARTS

TRACTOR -- MODEL NUMBER BI12970A

SEAT

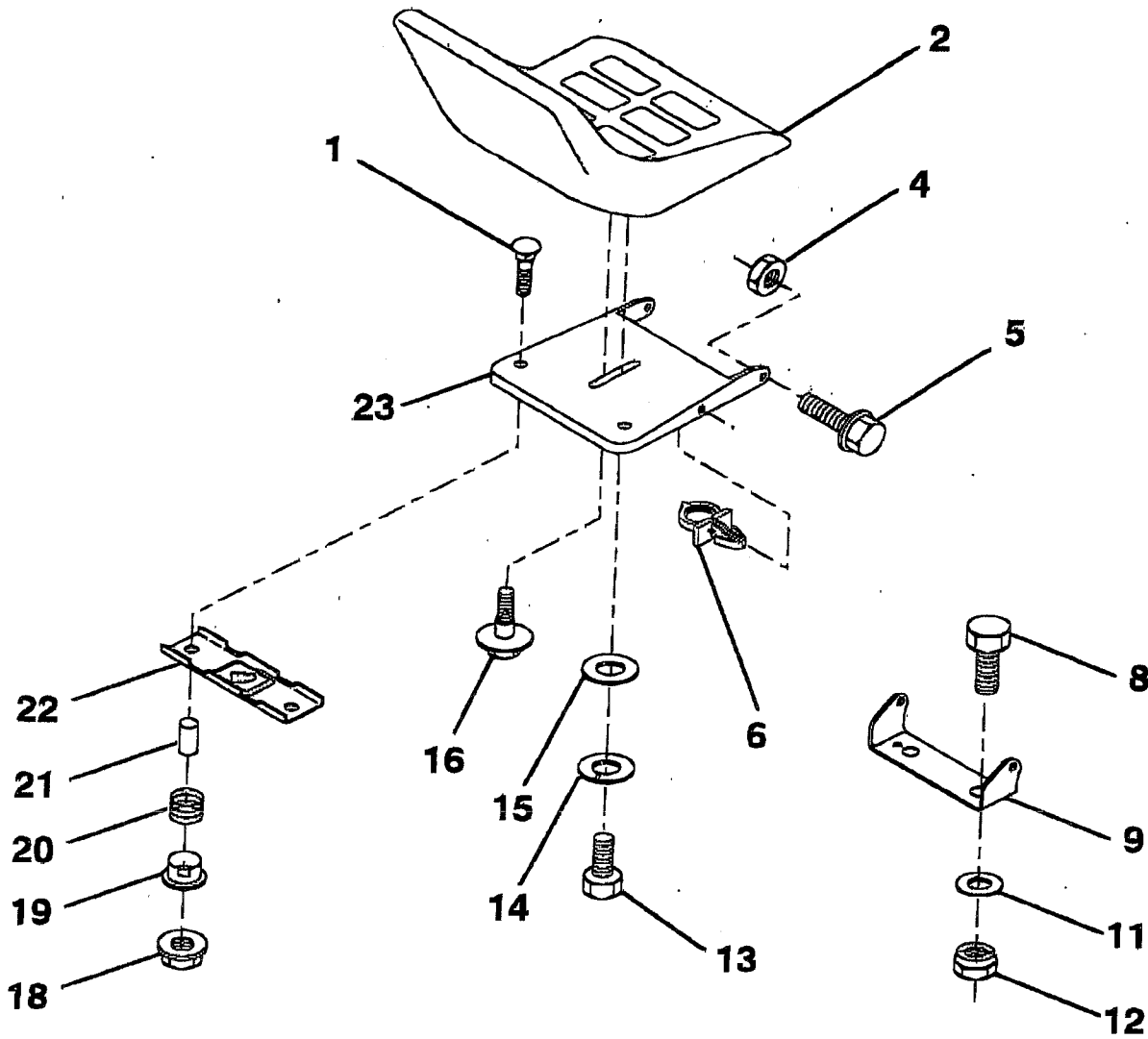

KEY NO.	PART NO.	DESCRIPTION
1	72050411	Bolt, Carriage 1/4-20 x 1-3/8
2	127427X	Seat
4	73800500	Nut, Lock Hex w/Ins. 5/16-18
5	139888	Bolt, Shoulder 5/16-18 UNC
6	145006	Clip, Push-In
8	74760616	Bolt, Hex, Fin 3/8-16 UNC x 1
9	140551	Bracket, Pivot, Seat
11	19133210	Washer 13/32 x 2 x 10 Gauge
12	73800600	Nut, Lock Hex w/Wsh 3/8-16 UNC
13	74780814	Bolt, Fin Hex 1/2-13 X 7/8 Gr. 5
14	10040800	Washer LockHvy Hlcl Spr. 1/2

KEY NO.	PART NO.	DESCRIPTION
15	19171912	Washer 17/32 x 1-3/16 x 12 Gauge
16	127018X	Bolt, Shoulder
18	123978X	Locknut, Hex, Large, Flange
19	121248X	Bushing, Snap
20	121250X	Spring, Compression
21	134300	Spacer, Split, Large .28 Id. x .96
22	121246X	Bracket, Switch, Mounting
23	140552	Pan, Seat

NOTE: All component dimensions given in U.S. Inches
1 inch = 25.4 mm

REPAIR PARTS

TRACTOR -- MODEL NUMBER BI12970A

DASHBOARD

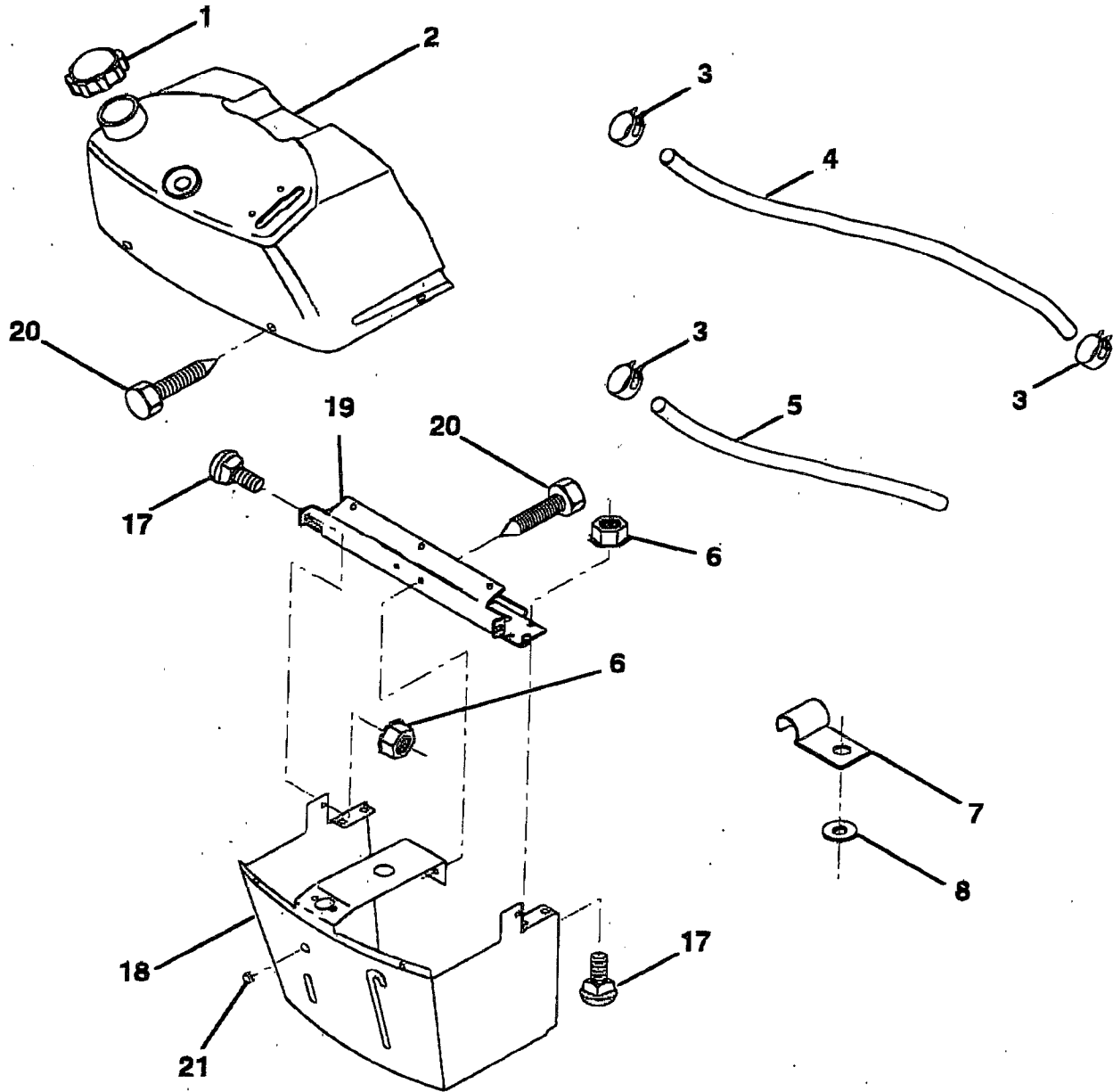

KEY NO.	PART NO.	DESCRIPTION
1	141523	Cap, Fuel
2	138392	Assembly, Dash & Fuel Tank
3	123487X	Clamp, Hose
4	8544R	Line, Fuel
5	8548R	Line, Fuel
6	73640400	Nut, Hex, Keps 1/4-20
7	2751R	Clip, Fuel Line
8	19091216	Washer 9/32 x 3/4 x 16 Gauge

KEY NO.	PART NO.	DESCRIPTION
17	72110404	Bolt, Carriage 1/4-20 x 1/2 Grade 5
18	131886	Support Assembly, Dash
19	134744	Brace, Cross
20	17060408	Screw, Self-Tapping 1/4-20 x 1/2
21	134014	Plug, Dome

NOTE: All component dimensions given in U.S. Inches
1 inch = 25.4 mm

REPAIR PARTS

TRACTOR -- MODEL NUMBER B112970A

STEERING WHEEL

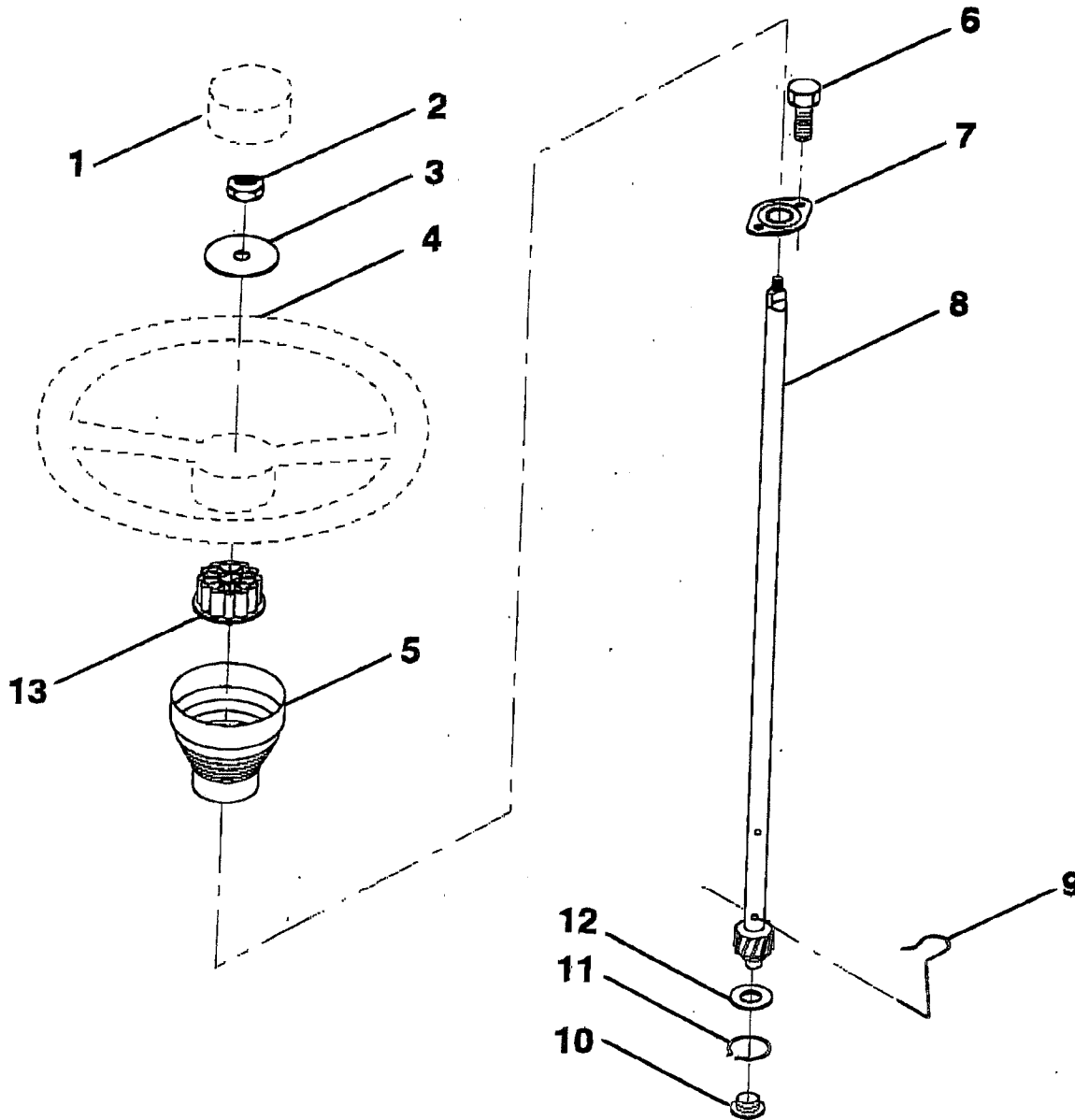

KEY NO.	PART NO.	DESCRIPTION
1	121584X	Insert, Steering Wheel
2	7810H	Locknut 3/8-24 UNF
3	19133808	Washer 13/32 x 2-3/8 x 8 Gauge
4	140044	Wheel, Steering
5	121897X	Sleeve, Steering
6	17431008	Screw, Hex Self-Tapping #10-16 x 1/2
7	102803X	Bushing, Steering

KEY NO.	PART NO.	DESCRIPTION
8	123651X	Shaft, Steering
9	124210X	Clip, Steering
10	123438X	Bushing, Lower, Steering
11	12000045	Ring, Retaining
12	19211616	Washer 21/32 x 1 x 16 Gauge
13	104820X	Adaptor, Steering Wheel

NOTE: All component dimensions given in U.S. inches
1 inch = 25.4 mm

TRACTOR -- MODEL NUMBER BI12970A

SECTOR GEAR / AXLE SUPPORT

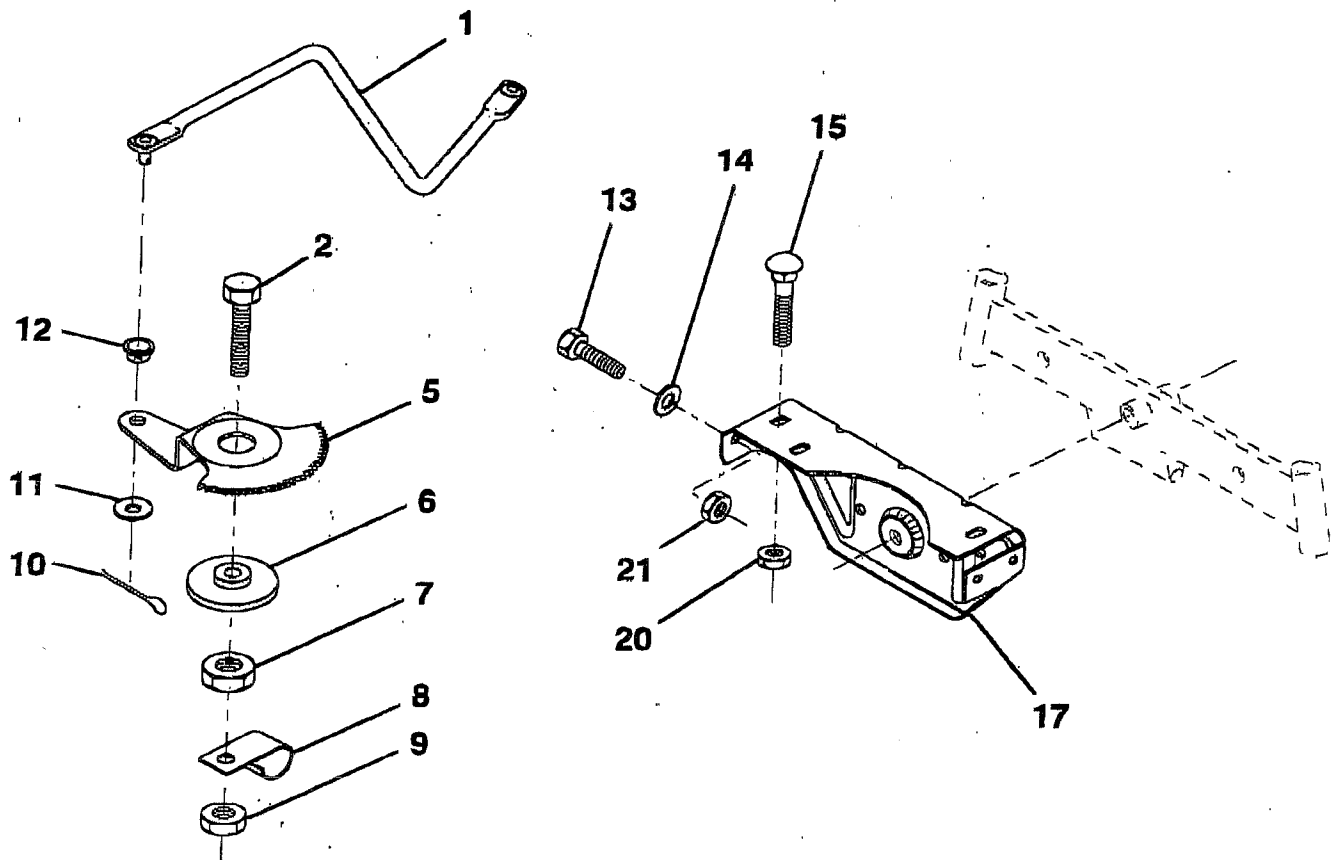

KEY NO.	PART NO.	DESCRIPTION
1	132566	Link, Drag
2	74780828	Bolt, Hex, Fin. 1/2-13 x 1-3/4
5	121926X	Gear, Sector
6	121927X	Bushing
7	73030800	Nut, Heavy, Hex, Top Lock 1/2-13 UNC
8	126472X	Clip, Wire
9	73680800	Nut, Crownlock 1/2-13
10	76020412	Pin, Cotter 1/8 x 3/4
11	19131316	Washer 13/32 x 13/16 x 16 Gauge

KEY NO.	PART NO.	DESCRIPTION
12	126847X	Bushing
13	74760512	Bolt, Hex 5/16-18 UNC x 3/4
14	19111416	Washer 11/32 x 7/8 x 16 Gauge
15	72110606	Bolt, Carriage 3/8-16 UNC x 3/4
17	137096	Support, Front Axle
20	73680600	Nut, Crownlock 3/8-16
21	73680500	Nut, Crownlock 5/16-18

NOTE: All component dimensions given in U.S. inches
1 inch = 25.4 mm

REPAIR PARTS

TRACTOR -- MODEL NUMBER BI12970A

FRONT AXLE

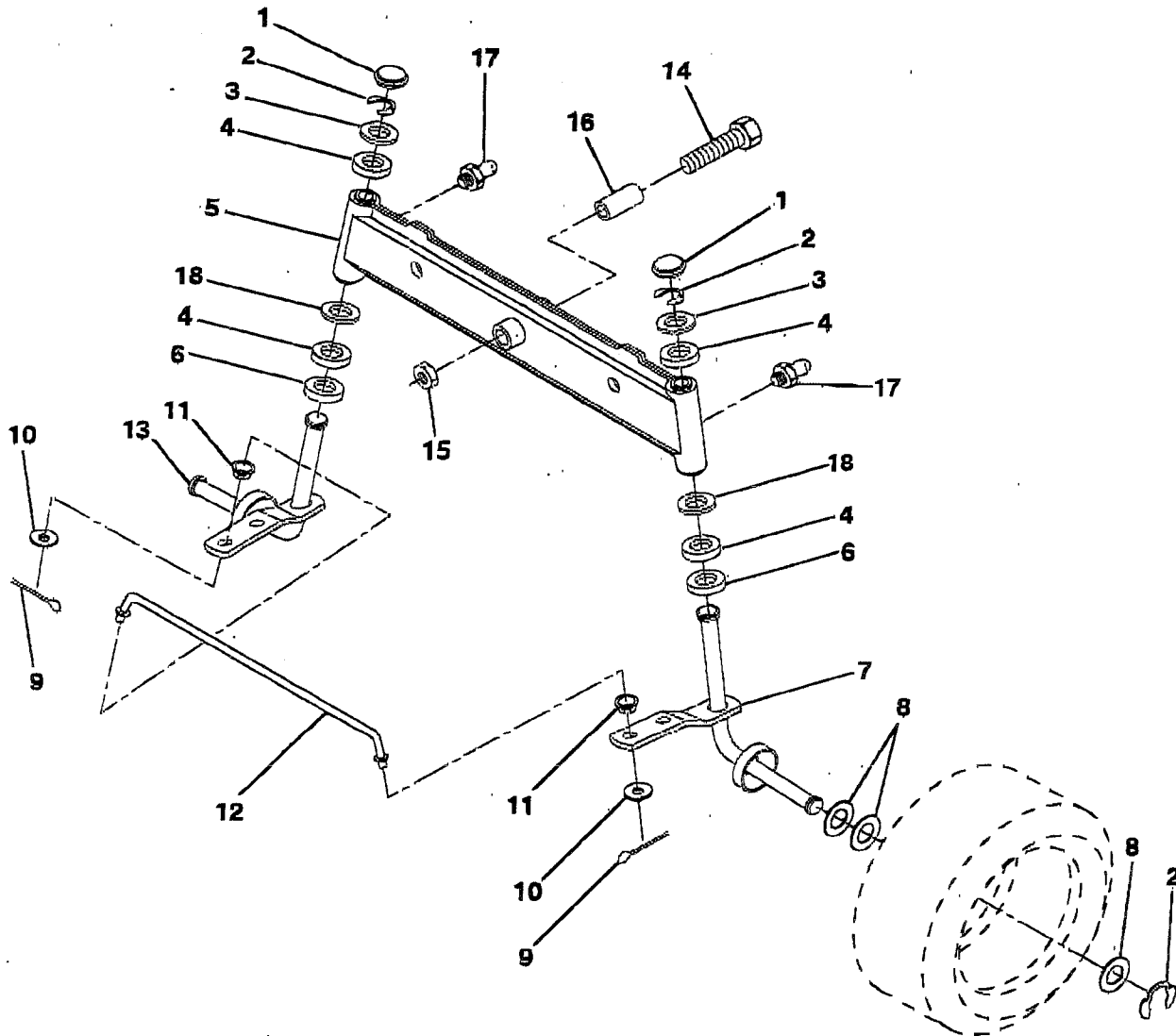

KEY NO.	PART NO.	DESCRIPTION
1	121232X	Cap, Spindle
2	12000029	Ring, Klip
3	121748X	Washer 25/32 x 1-5/8 x 16 Gauge
4	3366R	Bearing Col. Strg.
5	142033	Axle, Front
6	6266H	Bearing, Thrust
7	137062	Spindle Assembly, RH
8	121749X	Washer 25/32 x 1-1/4 x 16 Gauge
9	76020412	Pin, Cotter 1/8 x 3/4
10	19131316	Washer 13/32 x 13/16 x 16 Gauge

KEY NO.	PART NO.	DESCRIPTION
11	126847X	Bushing
12	130465	Rod, Tie
13	137061	Spindle Assembly, LH
14	74011056	Bolt, Hex 5/8 - 11 x 3-1/2
15	73901000	Nut, Lock Flange 5/8 - 11
16	110438X	Spacer Bearing Axle Front
17	6855M	Fitting Grease
18	19272016	Washer 27/32 x 1-1/4 x 16 Ga.

NOTE: All component dimensions given in U.S. inches
1 inch = 25.4 mm

REPAIR PARTS

TRACTOR -- MODEL NUMBER B112970A

BRAKE / REAR MOWER LIFT ASSEMBLY

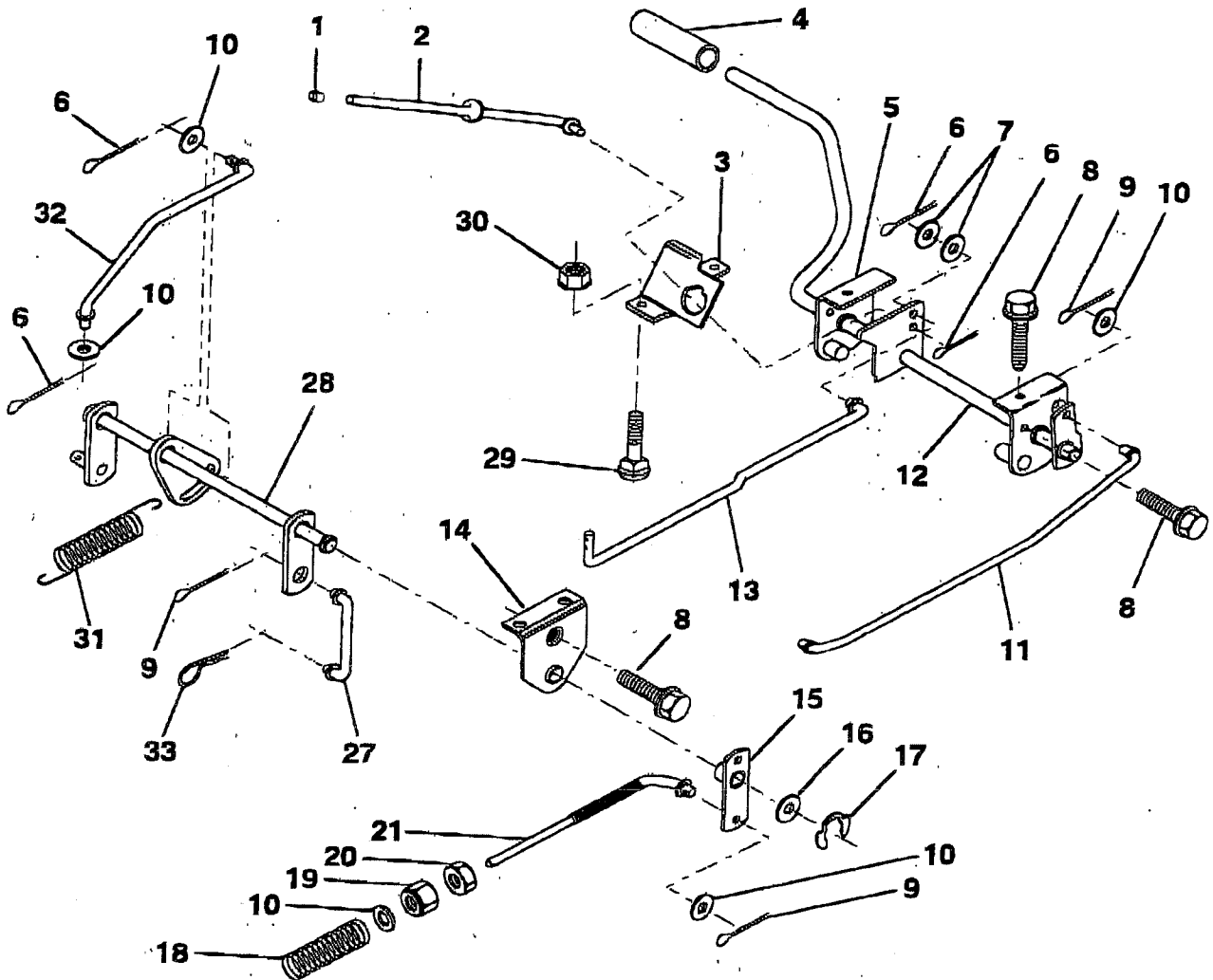

KEY NO.	PART NO.	DESCRIPTION
1	71673	Cap, Plunger
2	123436X	Rod, Parking Brake
3	123437X	Bracket, Parking Brake
4	8883R	Cover, Pedal
5	132205	Bracket Assy., Clutch Pedal, LH
6	76020312	Pin, Cotter 3/32 x 3/4
7	19131016	Washer 13/32 x 5/8 x 16 Gauge
8	17490508	Screw, Hex, Thd. Roll. 5/16-18 x 1/2
9	76020412	Pin, Cotter 1/8 x 3/4
10	19131316	Washer 13/32 x 13/16 x 16 Gauge
11	123543X	Rod, Front Brake
12	139934	Assembly, Clutch/Brake Pedal
13	123394X	Rod, Clutch
14	121978X	Bracket, Lift, Shaft
15	133332	Assembly, Brake, Pivot, Arm

KEY NO.	PART NO.	DESCRIPTION
16	19251816	Washer 25/32 x 1-1/8 x 16 Gauge
17	12000034	Ring, Klip
18	106888X	Spring, Brake Rod
19	73680600	Nut, Crownlock 3/8-16
20	73350600	Nut, Hex, Jam 3/8-16 UNC
21	131460	Rod, Rear Brake
27	136780	Link, Lift Rear
28	140777	Assembly, Rear Mower Lift
29	72110506	Bolt, Carriage 5/16-18 UNC x 3/4
30	73510500	Nut, Keps 5/16-18 UNC
31	133095	Spring, Counterbalance
32	133721	Link, Lift Lever
33	4939M	Retainer Spring

NOTE: All component dimensions given in U.S. inches
1 inch = 25.4 mm

REPAIR PARTS

TRACTOR -- MODEL NUMBER B112970A

ENGINE / THROTTLE

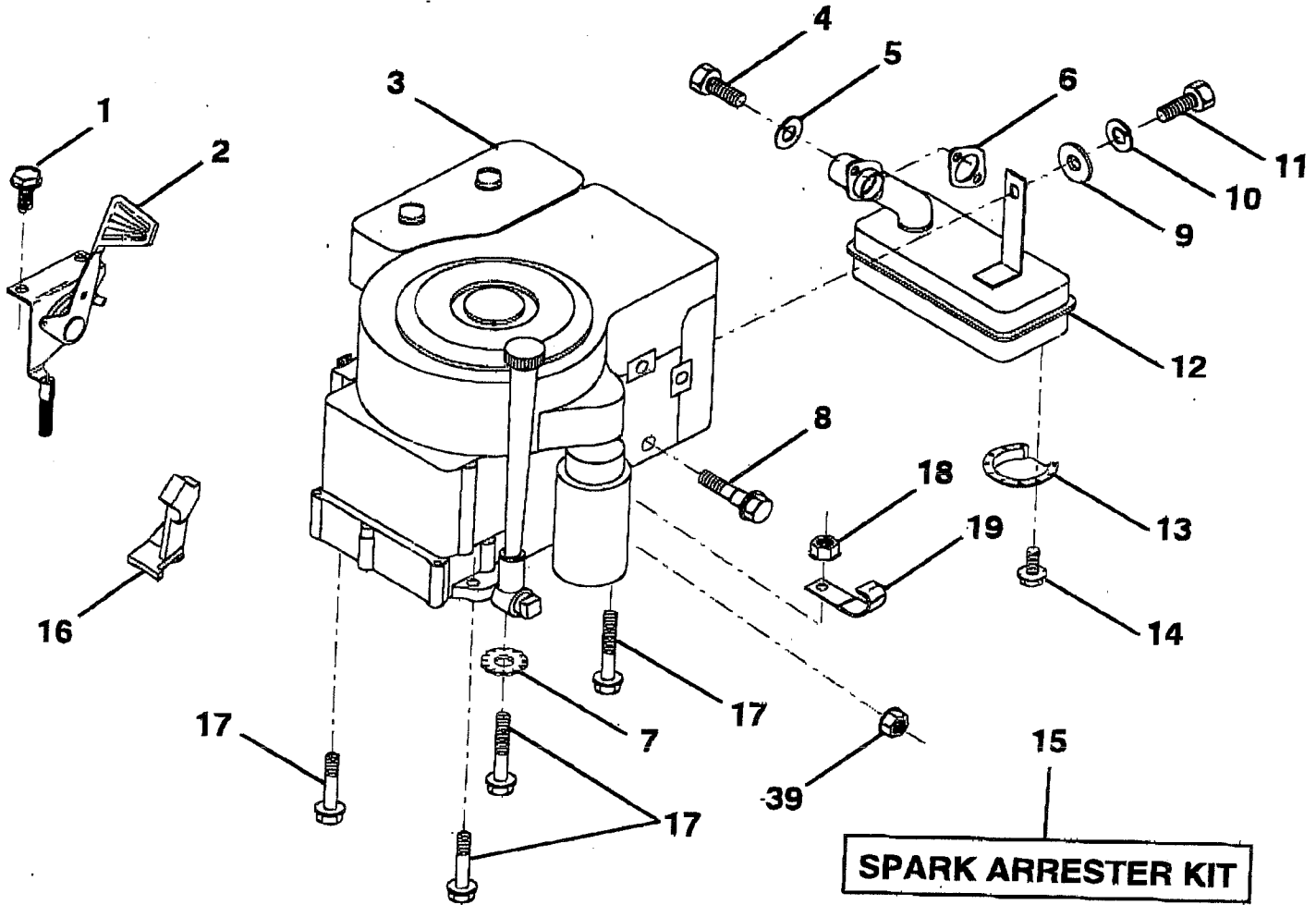

KEY NO.	PART NO.	DESCRIPTION
1	17060408	Screw, Hex, Thread Cutting 1/4-20 x 1/2
2	133025	Control, Throttle
3	-----	Engine, B&S, (Model No. 289707)
4	71070512	Screw, Hex Head Cap 5/16-18 x 3/4
5	10040500	Washer, Lock, Hvy Hlcl Sprng 5/16
6	125593X	Gasket, Exhaust
7	11050600	Washer Lock Ext. Tooth 3/8
8	121094X	Bolt, Shoulder
9	19101216	Washer 5/16 x 3/4 x 16 Gauge
10	10040400	Washer, Lock, Hvy Hlcl Spring 1/4
11	-----	Bolt, Hex, Fin. 1/4-20 UNC x 3/4 (Order from Engine mfg.)

KEY NO.	PART NO.	DESCRIPTION
12	137437	Muffler
13	101326L	Deflector, Muffler
14	17030808	Screw, Spiderloc
15	137180	Kit, Spark Arrester (Optional)
16	127951	Stop, Throttle .3000 RPM
17	17490624	Screw, Hex Washer Head, Thd. Roll. 3/8-16 x 1-1/2
18	73510600	Nut Keps Hex 3/8 - 16
19	2751R	Clip Line Fuel 13/32
39	73510400	Nut, Keps, Hex 1/4-20

NOTE: All component dimensions given in U.S. inches
1 inch = 25.4 mm

REPAIR PARTS

TRACTOR - - MODEL NUMBER BI12970A

GROUND DRIVE

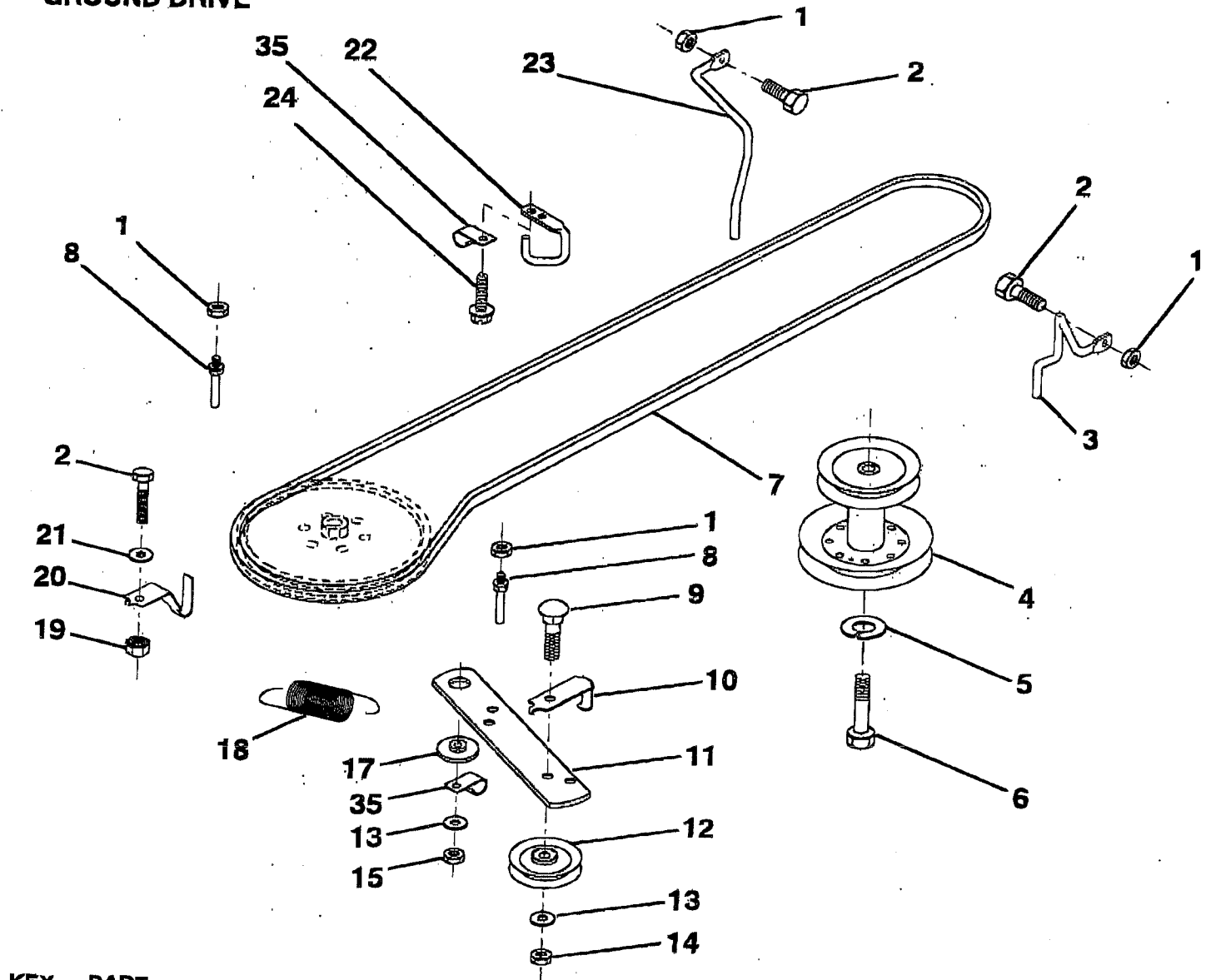

KEY NO.	PART NO.	DESCRIPTION
1	73680500	Nut, Crownlock 5/16-18
2	74760512	Bolt, Hex 5/16-18 UNC x 3/4
3	141341	Keeper, Mower Drive Belt, Engine
4	138029	Pulley, Engine
5	10040700	Washer, Lock 7/16
6	71170744	Bolt, Hex, Fin 7/16-20 Grade 5
7	124525X	Traction, V-Belt Drive
8	123405X	Keeper, T/A Ground Drive Belt
9	72140612	Bolt, Carriage 3/8-16 x 1-1/2
10	123396X	Keeper, Ground Drive Belt, Idler
11	140911	Arm, Ground Drive Clutch
12	123674X	Idler, Flat
13	19131316	Washer 13/32 x 13/16 x 16 Gauge

KEY NO.	PART NO.	DESCRIPTION
14	73930600	Nut, Centerlock 3/8-16 UNC
15	73680600	Nut, Crownlock 3/8-16 UNC
17	122052X	Spacer, Retainer
18	131459	Spring, Extension
19	73510500	Nut, Keps 5/16-18 UNC
20	139919	Keeper, T/A Ground Drive Belt
21	19111016	Washer 11/32 x 5/8 x 16 Gauge
22	123404X	Keeper, Frame, Ground Drive Belt
23	146792	Keeper Belt Lh Front
24	17720408	Screw, Thdcut 1/4-20 x 1/2
35	126472X	Clip, Insulated

NOTE: All component dimensions given in U.S. inches
1 inch = 25.4 mm

REPAIR PARTS

TRACTOR - - MODEL NUMBER BI12970A

TRANSAXLE

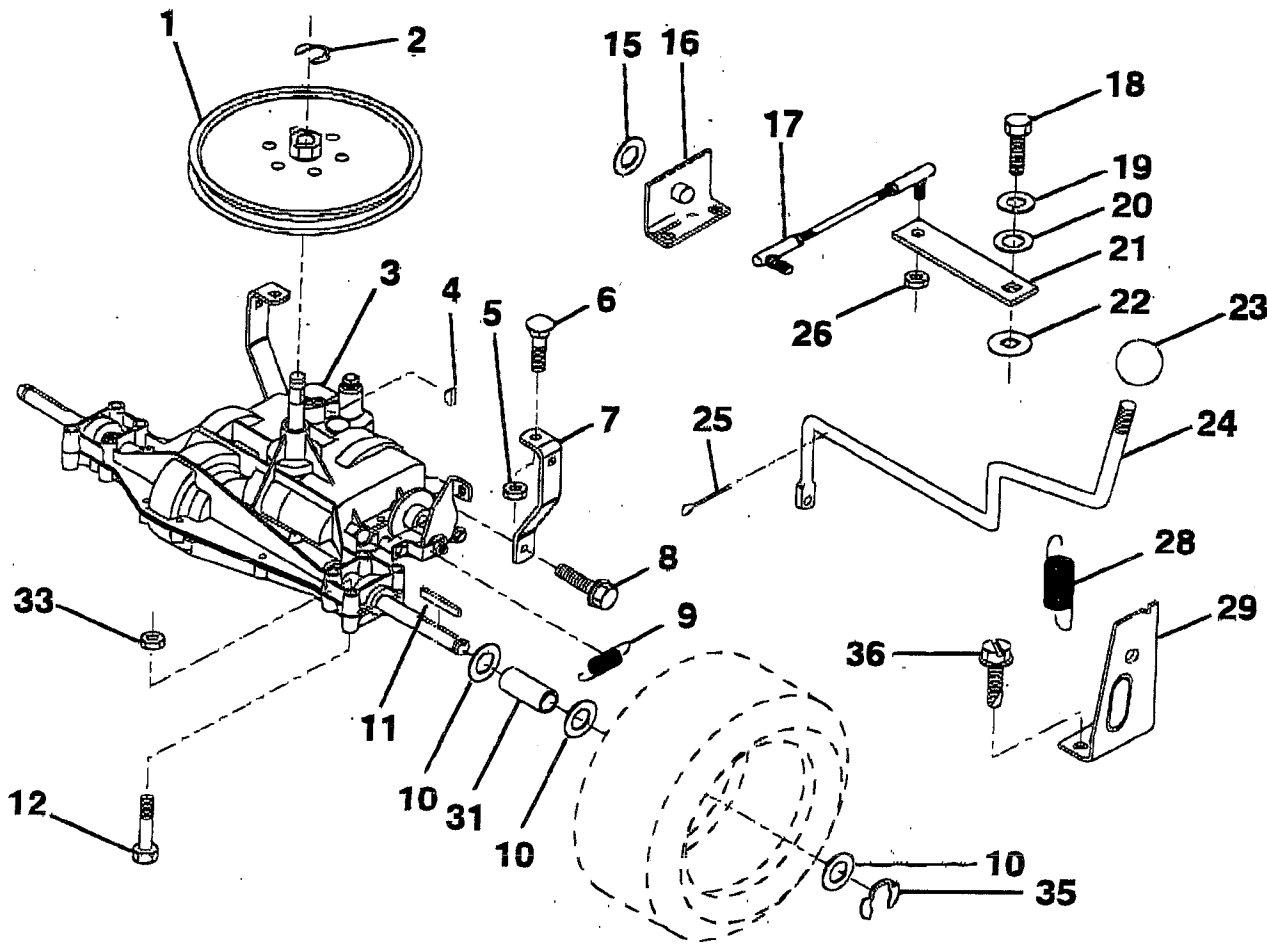

KEY NO.	PART NO.	DESCRIPTION
1	123385X	Pulley
2	12000028	Ring, Retainer
3	142603	Transaxle Dana, 6 speed, Model Number 4360-79
4	2228M	Key, Woodruff #9
5	73680500	Nut, Crownlock 5/16-18
6	72140506	Bolt, Carriage 5/16-18 x 3/4
7	123378X	Strap, Torque
8	17490512	Screw, Hex, Thdrl H 5/16-18 x 3/4
9	146682	Spring, Brake
10	121749X	Washer 25/32 x 1-1/4 x 16 Ga.
11	123583X	Key, Square
12	74760644	Bolt Hex 3/8-16 x 2-3/4
15	19171616	Washer 17/32 x 1 x 16 Ga.
16	124600X	Support Handle Shift LH
17	123632X	Link, Shift
18	74550412	Bolt Hex 1/4-28 x 3/4 Cat. 8

KEY NO.	PART NO.	DESCRIPTION
19	10040400	Washer, Lock 1/4
20	19091210	Washer 9/32 x 3/4 x 10 Ga.
21	123539X	Arm, Shift
22	105701X	Washer, Shift Plate
23	106933X	Knob
24	128215	Rod, Shift
25	76020416	Pin, Cotter 1/8 x 1
26	73810500	Nut, Hex, Nylon 5/16-24
28	128085	Spring, Extension
29	128084	Support Handle Shift RH
31	109502X	Spacer
33	73680600	Nut Crownlock 3/8 -16 UNC
35	12000001	E Ring
36	17720408	Screw, Thdcut. 1/4-20 x 1/2

NOTE: All component dimensions given in U.S. inches
1 inch = 25,4 mm.

TRACTOR - - MODEL NUMBER BI12970A

MOWER LIFT LEVER

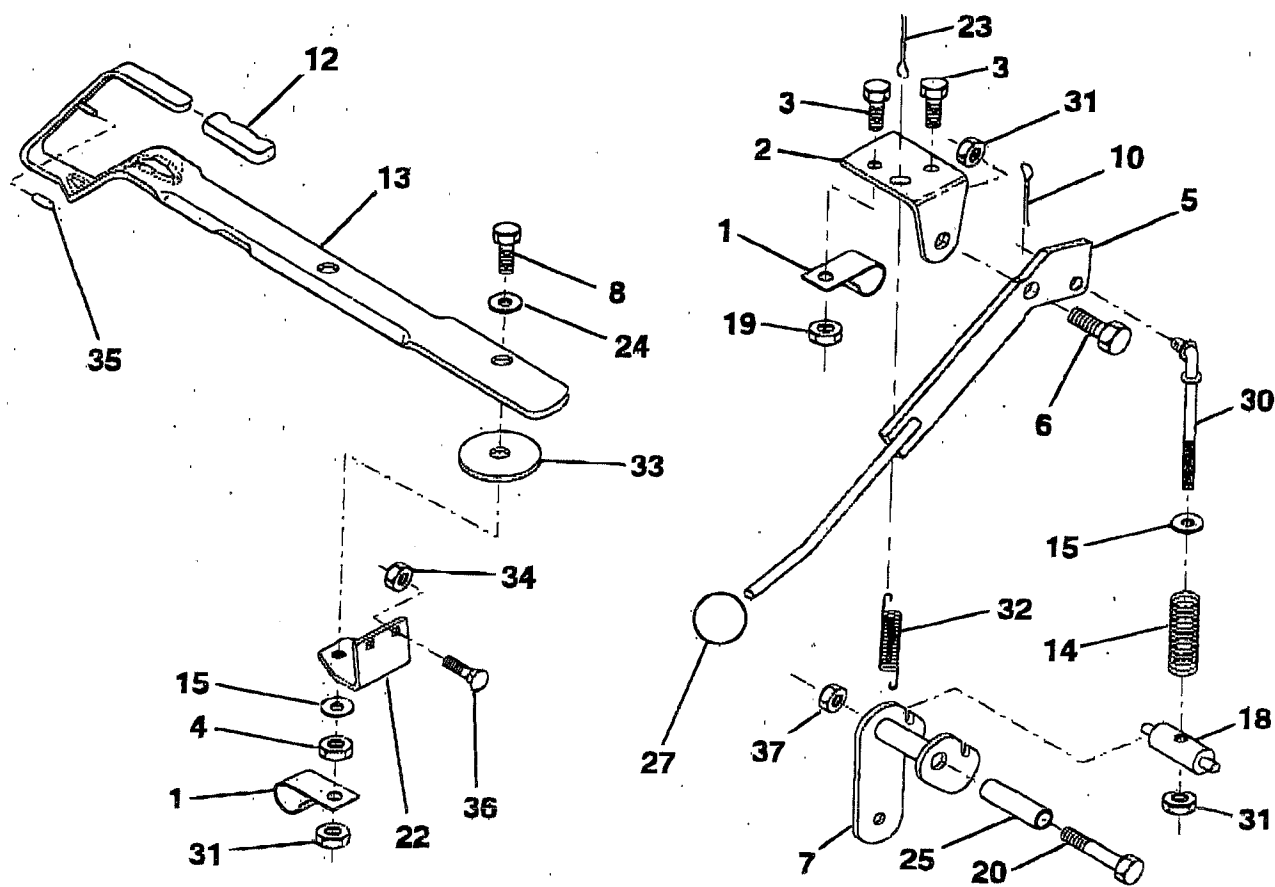

KEY NO.	PART NO.	DESCRIPTION
1	126470X	Clip, Fuel Line
2	122018X	Bracket, Mower Clutch
3	71110408	Bolt Hex 1/4-20 UNC x 1/2 Cat. 5
4	73930600	Nut, Centerlock 3/8-16
5	145187	Assembly, Clutch Lever
6	106451X	Bolt, Shoulder
7	141435	Assembly, Mower Clutch Arm
8	74930624	Bolt Hex 3/8-16 x 1-1/2
10	76020412	Pin, Cotter 1/8 x 3/4
12	122027X	Handle, Lift Lever
13	136658	Lever, Lift
14	133939	Spring, Compression, Clutch
15	19131616	Washer 13/32 x 1 x 16 Ga.
18	135107	Trunnion
19	73680400	Nut, Crownlock 1/4-20
20	74760644	Bolt Hex 3/8-16 UNC x 2-3/4

KEY NO.	PART NO.	DESCRIPTION
22	132561	Bracket, Lift Lever
23	76020312	Pin, Cotter 3/32 x 3/4
24	7672J	Washer 25/64 x 1-1/4 x 12 Ga.
25	121933X	Tube, Spacer
27	106932X	Knob
30	135039	Rod, Tension, Clutch
31	73800600	Nut Lock Hex W/Ins 3/8-16
32	133435	Spring, Extension, Return
33	62333	Washer
34	73800500	Nut, Lock Hex w/Wsh 5/16-18
35	133603	Cap, Vinyl, Red
36	72140506	Bolt, Carriage 5/16-18 x 3/4
37	73680600	Nut, Crownlock 3/8-16

NOTE: All component dimensions given in U.S. inches
1 inch = 25,4 mm.

TRACTOR -- MODEL NUMBER BI12970A

MOWER DECK

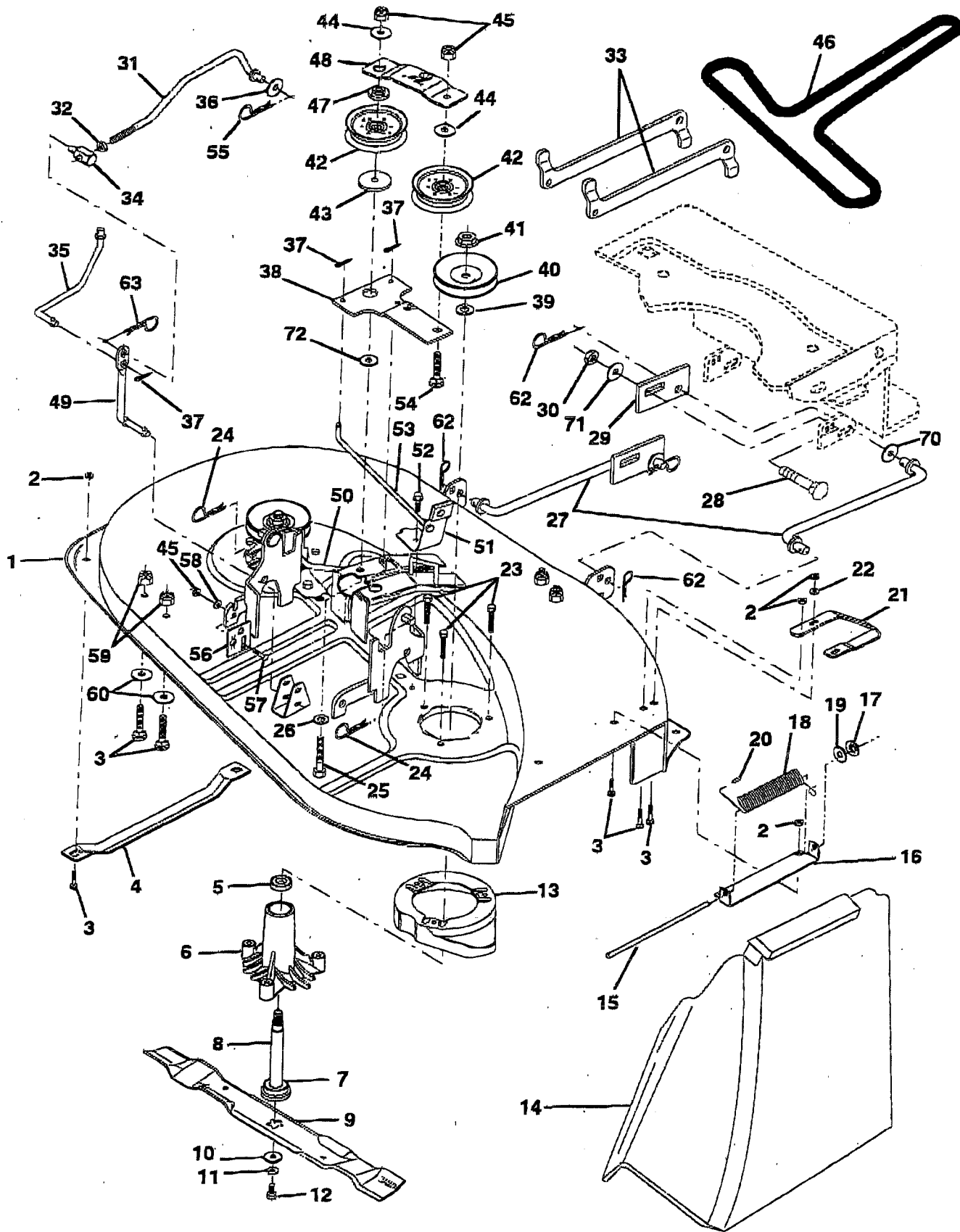

TRACTOR -- MODEL NUMBER B112970A

MOWER DECK

KEY NO.	PART NO.	DESCRIPTION	KEY NO.	PART NO.	DESCRIPTION
1	142830	Mower Deck Assembly	37	76020312	Pin, Cotter 3/32 x 3/4
2	73680500	Nut, Crownlock 5/16-18	38	133840	Idler Arm
3	72140506	Bolt, Carriage 5/16-18 x 3/4	39	129963	Washer .150 Thick
4	7631J	Runner, L.H.	40	129206	Pulley, Mandrel
5	110485X	Bearing	41	137266	Nut, Flangelock 9/16
6	128774	Housing, Mandrel	42	121316X	Pulley, Flat Idler
7	129895	Bearing	43	122052X	Spacer, Retainer
8	137645	Shaft & Bearing Assembly, Mandrel (Includes Key #7)	44	19131612	Washer 13/32 x 1 x 12 Gauge
9	138497	Blade, High Lift	45	73680600	Nut, Crownlock 3/8-16
10	140296	Washer, Hard	46	126520X	Belt
11	10030600	Washer, Lock 3/8	47	133502	Spacer, Idler Arm
12	850857	Bolt 3/8-24 x 1-1/4 Grade 8	48	133503	Stiffener, Idler Arm
13	140329	Stripper, Mower, Vented	49	133551	Rod, Pivot
14	106736X	Shield, Deflector	50	131289	Rod, Brake, L.H.
15	106735X	Rod, Hinge	51	130840	Brake Assembly
16	137607	Bracket Assembly, Deflector	52	17490512	Screw, Hex Washer Head, Thd., Roll. 5/16-18 x 3/4
17	110452X	Pushnut	53	131288	Rod, Brake, R.H.
18	123713X	Spring, Torsion	54	72110614	Bolt, Carriage 3/8-16 x 1-3/4 Grade 5
19	19111016	Washer 11/32 x 5/8 x 16 Gauge	55	4921H	Retainer Spring
20	105304X	Cap, Sleeve	56	136782	Plate Adj. Link Rear
21	128772	Runner, R.H.	57	72140608	Bolt Carriage 3/8 - 16 Unc X 1
22	19111216	Washer 11/32 x 3/4 x 16 Gauge	58	19131212	Washer 13/32 x 3/4 x 12 Ga.
23	138776	Screw Throl Hex Hd Zinc Mwr	59	73680500	Nut, Crownlock 5/16-18
24	4939M	Retainer, Spring	60	19111112	Washer 11/32 x 11/16 x 16 Ga.
25	74600636	Bolt, Carriage 3/8-16 x 2-1/4	62	3146R	Retainer Spring
26	19131612	Washer 13/32 x 1 x 12 Gauge	63	4497H	Spring, Retainer
27	139756	Link, Lift	70	19162016	Washer 1/2 x 1-1/4 x 16 Ga.
28	72140608	Bolt, RhHd Sqnk 3/8-16 x 1	71	19131610	Washer, Flat 13/32 x 1 x 10 Ga.
29	139757	Plate, Slide Link	72	133943	Washer Hardened
30	73800600	Nut, Lock Hex w/Wsh 3/8-16	--	144975	Mower Deck, Serv. 38 HP, LR
31	140915	Rod, Clutch, Primary	--	130794	Mandrel Asm (Includes Key #'s 5-8, 10-12, 39 and 41)
32	73350600	Nut, Hex, Jam 3/8-16			
33	132559	Arm, Suspension, Rear			
34	133604	Trunnion 3/8-16			
35	132554	Rod, Clutch, Secondary			
36	19131316	Washer 13/32 x 13/16 x 16 Gauge			

NOTE: All component dimensions given in U.S. inches
1 inch = 25.4 mm

WHEELS & TIRES

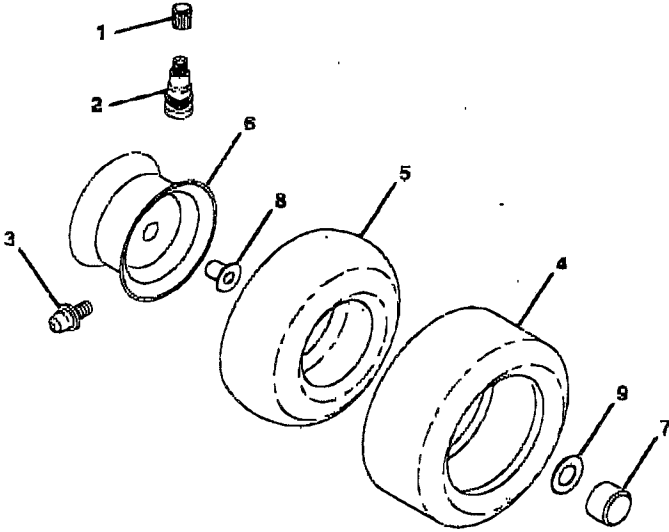

KEY NO.	PART NO.	DESCRIPTION
1	59192	Cap, Valve
2	65139	Stem, Valve
3	278H	Fitting, Grease (Front Only)
4	137422	Tire, Front
	132703	Tire, Rear
5	59904	Tube, Tire, Front
	8134H	(Not Supplied, Service Item Only)
	8134H	Tube, Tire, Rear
	8134H	(Not Supplied, Service Item Only)
6	122394X427	Rim, Front
	140325X427	Rim, Rear
7	104757X	Cap, Axle (Front and Rear)
8	9040H	Bearing, Flange (Front only)
9	121748X	Washer 25/32 x 1-5/8 x 16 Gauge
--	144334	Sealant, Tire (10 oz. Tube)

NOTE: All component dimensions given in U.S. inches
1 inch = 25.4 mm

TRACTOR -- MODEL NUMBER BI12970A

DANA TRANSAXLE - MODEL NUMBER 4360-79

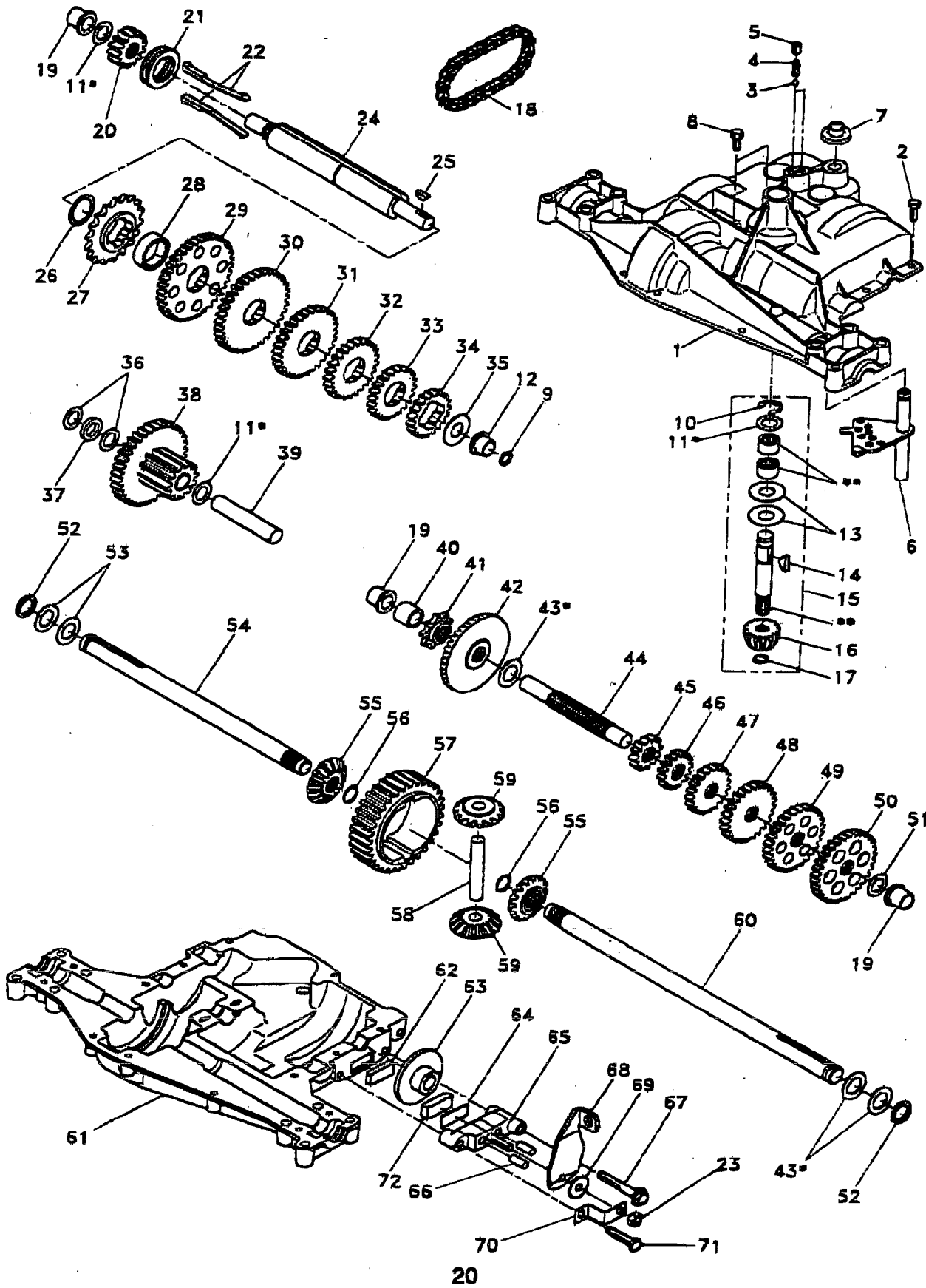

REPAIR PARTS**TRACTOR -- MODEL NUMBER BI12970A****DANA TRANSAXLE - MODEL NUMBER 4360-79**

KEY PART NO. NO.	DESCRIPTION	KEY PART NO. NO.	DESCRIPTION
1 142671	Housing, Upper	41 105928X	Sprocket, 9 Teeth
2 2274J	Screw, Self-Tapping, Large 1/4-20 x .734	42 110084X	Gear, Bevel, 42 Teeth
3 134400	Ball, Detent	43 134394	* Assembly, Kit, Shim .750 Shaft
4 105904X	Spring, Detent	44 120473X	Shaft, Drive
5 105905X	Screw, Set	45 142678	Gear, Spur, 12 Teeth
6 138235	Kit, Shifter Assembly	46 142679	Gear, Spur, 15 Teeth
7 134399	Boot, Shifter	47 120407X	Gear, Spur, 20 Teeth
8 134791	Screw, Tapping w/Sealer	48 106589X	Gear, Spur, 25 Teeth
9 138241	Square Ring	49 120408X	Gear, Spur, 28 Teeth
10 142672	Ring, Retaining	50 105937X	Gear, Spur, 31 Teeth
11 134793	* Assembly, Kit, Shim .625 Shaft	51 2226J	Washer, Plain .632 x 1.00 x .060
12 142673	Bearing, Flange	52 134401	Washer, Neoprene
13 120415X	Washer, Plain .632 x 1.38 x .046	53 2264J	Washer, Plain .758 x 1.25 x .031
14 142674	Key, Woodruff, #9	54 120474X	Axle, L.H.
15 138234	Assembly, Kit, Input Shaft	55 110081X	Gear, Miter, 15 Teeth
16 110078X	Pinion, Bevel, 14 Teeth	56 105941X	Ring, Retaining
17 105909X	Ring, Retaining	57 110071X	Gear, Spur, 32 Teeth
18 105910X	Chain, 24 Pitches	58 120952X	Shaft, Cross
19 105911X	Bearing, Flange	59 110082X	Gear, Miter, 15 Teeth
20 142675	Gear, Spur, 14 Teeth	60 120475X	Axle, R.H.
21 138246	Collar, Clutch	61 142680	Housing, Lower
22 138236	Assembly, Kit, Clutch Keys	62 120961X	Puck, Friction
23 73810500	Locknut 5/16-24	63 7294J	Disc, Brake
24 142676	Shaft, Intermediate	64 108989X	Spacer
25 2244J	Key, Woodruff, #61	65 120953X	Jaw, Brake
26 105916X	Ring, Retaining	66 120954X	Pin, Dowel
27 120470X	Sprocket, 18 Teeth	67 134799	Screw, Self-Tapping, Large 5/16-18 x 2.25
28 110070X	Spacer	68 138244	Lever, Actuating
29 142677	Gear, Spur, 37 Teeth	69 108996X	Washer, Plain .321 x 1.00 x .055
30 142681	Gear, Spur, 35 Teeth	70 120956X	Bracket, Anti-Rotation
31 120405X	Gear, Spur, 30 Teeth	71 106596X	Screw, Self-Tapping, Large 5/16-18 x 1.44
32 108980X	Gear, Spur, 25 Teeth	72 120951X	Puck, Friction
33 120406X	Gear, Spur, 22 Teeth	73 120416X	Grease
34 134796	Gear, Spur, 19 Teeth		
35 105925X	Washer, Plain .640 x 1.37 x .061		
36 2232J	Washer, Plain .632 x 1.00 x .026		
37 108978X	Spacer .630 x 1.00 x .169		
38 110079X	Assembly, Gear, Combination of 12 Teeth and 35 Teeth		
39 124639X	Shaft, Idler		
40 120472X	Spacer .635 x .875 x .755		

* Use in combinations to maintain proper clearances

** Order Key No. 15

NOTE: All component dimensions given in U.S. inches
1 inch = 25.4 mm