

OV691EA/OV691EP (TVT691/VTX691)

Four-Cycle Twin Cylinder Engine • Vertical Crankshaft • Air-Cooled

Table of Contents

IMPORTANT NOTICE! Safety Definitions	ii
I. General Safety Precautions	1
II. How to Get Service	3
III. Oil and Fuel Specifications	4
IV. Before Starting Your Engine	4
V. Starting Your Engine.....	6
VI. Stopping Your Engine and Short-Term Storage.....	8
VII. Maintenance.....	8
VIII. Transporting Your Engine	12
IX. Storing Your Engine.....	12
X. Preventing Forest, Brush and Grass Fires	14
XI. Maintenance Intervals	14
California & US EPA Emission Control Warranty Statement	20
Emission Control System Warranty.....	21
XII. Warranty Information.....	22

IMPORTANT NOTICE!

Safety Definitions

Statements in this manual preceded by the following words and graphics are of special significance:

WARNING

Or

WARNING

WARNING indicates a potentially hazardous situation which if NOT avoided, could result in death or serious injury.

CAUTION

Indicates a potentially hazardous situation which, if NOT avoided, may result in minor or moderate injury.

CAUTION

Indicates a potential situation which, if NOT avoided, could result in equipment or property damage.

NOTE

Refers to important information and is placed in italic type.

It is recommended that you take special notice of all items discussed on the next two pages and wear the appropriate safety equipment.

Before operating this engine *it is your responsibility* to read this Operator's Manual. Follow these basic rules for your personal safety:

- Keep this manual handy at all times for future reference.
- Read it carefully and familiarize yourself with operating, maintenance, components and safety instructions.

Notice Regarding Emissions

NOTE

Engines which are certified to comply with California and U.S. EPA emission regulations for SORE (Small Off Road Equipment), are certified to operate on regular unleaded gasoline, and may include the following emission control systems: (EM) Engine Modification and (TWC) Three-way Catalyst (if so equipped).

TecumsehPower Contact Information

For engine adjustments, repairs or warranty service NOT covered in this manual, contact your nearest Authorized TecumsehPower Servicing Dealer. Find them on our website at www.TecumsehPower.com or call TecumsehPower Company at 1-800-558-5402 for additional information.

The trademarks TECUMSEH® and the DESIGN (Native American Head logo) are registered trademarks of Tecumseh Products Company and are used by TecumsehPower Company under license from Tecumseh Products Company. TecumsehPower Company is no longer owned by Tecumseh Products Company nor is it associated or affiliated in any way with Tecumseh Products Company.

©Copyright 2006, 2008

TecumsehPower Company

All Rights Reserved

I. General Safety Precautions

⚠ WARNING

Read equipment manufacturer's manual and this material thoroughly before using this engine. Failure to do so can result in serious injury or death. Consult your local Authorized TecumsehPower Servicing Dealer, call 1-800-558-5402, or go to www.TecumsehPower.com for additional information.

A. Avoid Carbon Monoxide Poisoning

All engine exhaust contains carbon monoxide, a deadly gas. Breathing carbon monoxide can cause headaches, dizziness, drowsiness, nausea, confusion and eventually death.

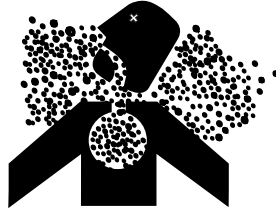

Carbon monoxide is a colorless, odorless, tasteless gas which may be present even if you DO NOT see or smell any engine exhaust. Deadly levels of carbon monoxide can collect rapidly and you can quickly be overcome and unable to save yourself. Also, deadly levels of carbon monoxide can linger for hours or days in enclosed or poorly-ventilated areas. If you experience any symptoms of carbon monoxide poisoning, leave the area immediately, get fresh air, and SEEK MEDICAL TREATMENT.

To prevent serious injury or death from carbon monoxide:

- NEVER run engine indoors. Even if you try to ventilate engine exhaust with fans or open windows and doors, carbon monoxide can rapidly reach dangerous levels.
- NEVER run engine in poorly-ventilated or partially enclosed areas such as barns, garages, basements, carports, under dwellings, or in pits.
- NEVER run engine outdoors where engine exhaust can be drawn into a building through openings such as windows and doors.

B. Avoid Gasoline Fires

Gasoline (fuel) vapors are highly flammable and can explode. Fuel vapors can spread and be ignited by a spark or flame many feet away from engine. To prevent injury or death from fuel fires, follow these instructions:



- NEVER store engine with fuel in fuel tank inside a building with potential sources of ignition such as hot water and space heaters, clothes dryers, electric motors, etc.
- NEVER remove fuel fill cap or add fuel when engine is running.
- NEVER start or operate the engine with the fuel fill cap removed.
- Allow engine to cool before refueling.

- NEVER fill fuel tank indoors. Fill fuel tank outdoors in a well-ventilated area.
- DO NOT smoke while refueling tank.
- Use only an approved red GASOLINE container to store and dispense fuel. TecumsehPower Company recommends purchasing gasoline in containers with a capacity of 2.5 gallons or less. Small containers are easier to handle and help eliminate spillage during refueling.
- DO NOT pour fuel from engine or siphon fuel by mouth. To empty the fuel tank, see "I. Draining Fuel" instructions on page 13.

C. Adult Supervision of Operation, Refueling and Maintenance

The manufacturer of the equipment may provide information about who is allowed to use this engine (see equipment manufacturer's manual). NOT everyone who is allowed to use this engine is capable of safely and responsibly operating, maintaining and/or fueling it. TecumsehPower Company recommends the following:

- An adult should fuel this engine. NEVER allow children to refuel this engine. See "C. Filling Fuel Tank" instructions on page 5.
- An adult should perform maintenance on this engine. See "VII. Maintenance" instructions on page 8. Only allow children to perform maintenance if an adult has determined they are experienced and capable of such operation.
- An adult should start the engine. See "G. Avoid Accidental Starts" instructions on page 2. Only allow children to start the engine if an adult has determined they are experienced and capable of such operation.
- To avoid unsupervised operation of the engine, especially by children, NEVER leave it unattended when it is running. Remove ignition key, if equipped.

D. Stay Away from Rotating Parts

NEVER operate the engine with an unguarded engine shaft or flywheel. See Figure 1 on page 2.

The equipment manufacturer may attach a sprocket and chain or pulley and belt to the engine shaft. If these parts are NOT properly guarded, or if you are NOT sure whether they are properly guarded, DO NOT use your engine; contact the equipment manufacturer. Hands, feet, hair, jewelry, clothing, etc., can become entangled in rotating parts, leading to serious injury or death. To avoid serious injury or death, be sure the flywheel guard is in place. See Figure 1 on page 2.

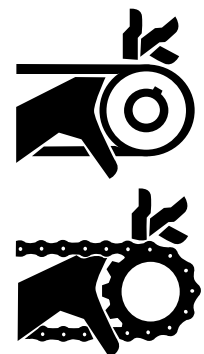

E. DO NOT Modify Engine

To avoid serious injury or death, DO NOT modify engine in any way. Tampering with the governor setting can lead to a runaway engine and cause it to operate at unsafe speeds. NEVER tamper with factory setting of engine governor.

⚠ WARNING

Use of this engine on fun-carts, go-karts, or mini-bikes can result in serious injury or death. TecumsehPower Company manufactures the Power Sport line of engines for use in such applications. Consult your local Authorized TecumsehPower Servicing Dealer, call 1-800-558-5402, or visit www.TecumsehPower.com for additional information.

F. Avoid Burns and Fire from Hot Surfaces

The muffler and other engine parts become extremely hot during operation and remain hot after the engine has stopped.



- To avoid severe burns on contact, STAY AWAY from hot areas of engine. DO NOT operate the engine without the muffler guard in place, if equipped.
- To reduce the risk of fire keep all materials that can burn, including grass and leaves, away from muffler and rest of engine. DO NOT operate, idle or park engine powered equipment in long dry grass or other dry ground cover.

G. Avoid Accidental Starts

NOTE

The Twin Cylinder Engines have **two** spark plug connections.

To prevent accidental starting when working on equipment always:

- Carefully disconnect spark plug wire and keep it away from spark plug. See Figures 2 and 3.
 - Keep the disconnected spark plug wire securely away from metal parts where arcing could occur.
 - Carefully attach the spark plug wire to the grounding post, if provided.
- Disconnect battery at negative terminal first, if engine is equipped with a DC electric starter.
- Turn all engine switches to “OFF” position.
- Remove ignition key, if provided.

H. Use Hearing Protection

Engine noise may cause hearing damage. Always wear hearing protection when operating an engine.

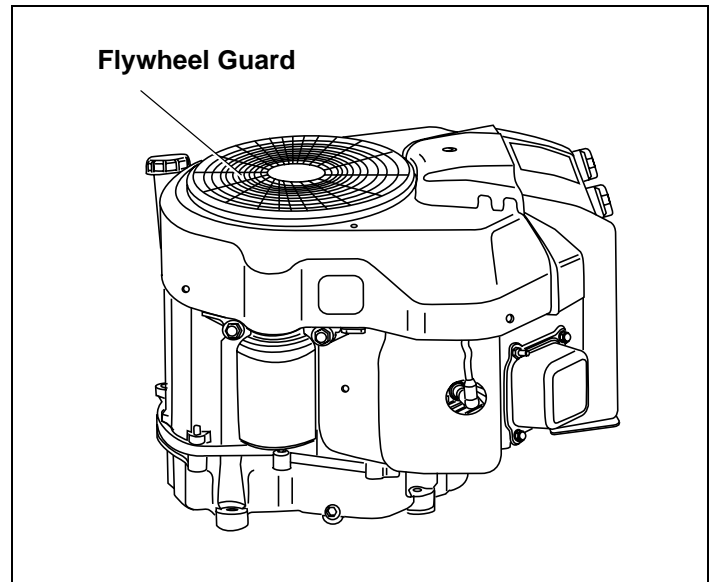

Figure 1. Typical Flywheel Guard Location

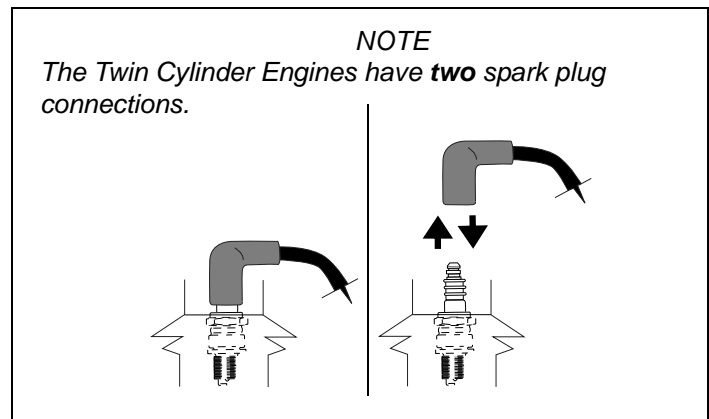

Figure 2. Disconnecting/Connecting Spark Plug

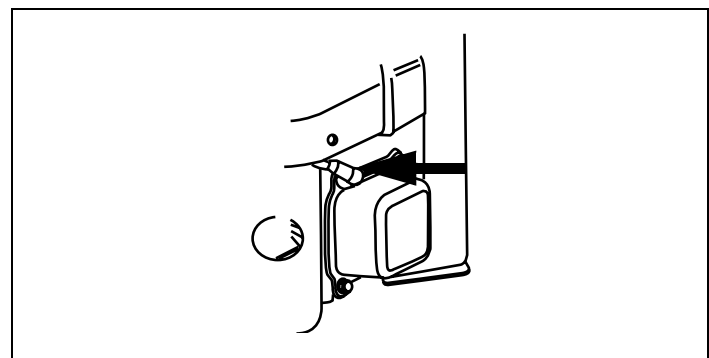

Figure 3. Typical Spark Plug Grounding Post

II. How to Get Service

For engine adjustments, repairs or warranty service NOT covered in this manual, contact your nearest Authorized TecumsehPower Servicing Dealer. Find them on our website at www.TecumsehPower.com or call TecumsehPower Company at 1-800-558-5402 for additional information.

Visit our web site at www.TecumsehPower.com

- ◆ Register Your TecumsehPower Engine
- ◆ Maintenance Tips
- ◆ On-Line Store
- ◆ Locate your nearest TecumsehPower Servicing Dealer

LOG ON!

A. Engine Identification Decal

A sample engine identification decal is located in the next column and indicates the engine's model number, specification and date of manufacture (DOM). See Figure 4.

NOTES

Please look at the decal on your engine.

Fill in the engine information in the spaces provided for future reference.

The engine identification decal also includes engine life specifications for the emissions-related useful life period of your engine. This period relates to the emission compliance life as certified by EPA and/or CARB.

- OV models are designated as "C" 250 hours, "B" 500 hours and "A" 1,000 hours.

B. Technician's Handbook

If you have a general understanding of internal combustion engines and wish to repair and service your engine and/or engine emission control systems yourself, a Technician's Handbook is available from your Authorized TecumsehPower Servicing Dealer. See Figure 5. This handbook covers repairs and adjustments not covered within this Operator's Manual, and it is intended for individuals who have had adequate training, experience and who practice proper tool usage. Service procedures should be clearly understood and practiced when servicing TecumsehPower engines.

- Order as part #696325 for V-Twin models.

TecumsehPower Company manufactures and is responsible only for the engine used on this power equipment. If repair or service is needed for anything other than the engine, contact the service source recommended by the equipment manufacturer.



Figure 4. Engine Identification Decal

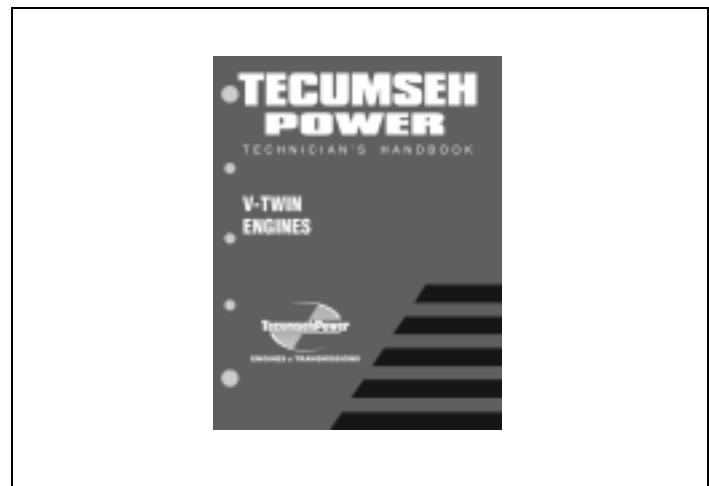

Figure 5. Technician's Handbook

III. Oil and Fuel Specifications

A. Oil

To operate engine you need to use a clean, high quality, detergent oil. For recommended engine oil, see Table 1. In addition, you need to be sure the oil sump contains the correct amount of oil to operate properly.

NOTES

The oil sump capacity (including oil filter) is 80 ounces or 5 U.S. Pints (2.36 liters).

The oil sump capacity (without oil filter) is 72 ounces or 4-1/2 U.S. Pints (2.12 liters).

Be sure original container is marked A.P.I. Service "SL/SJ".

Using multigrade oil above 32°F (0°C) will increase oil consumption. SAE 10W40 is NOT recommended.

Special-formulated oils are available at your Authorized TecumsehPower Servicing Dealer.

B. Fuel

Use unleaded regular, unleaded premium or reformulated automotive fuel only. You may use gasoline containing the components identified in Table 2.

- DO NOT use leaded fuel.
- Fuel must be fresh and clean. NEVER use fuel left over from last season or stored for long periods.
- NEVER mix oil with fuel.
- DO NOT use fuel containing Methanol (Wood Alcohol).

CAUTION

The use of alternative fuels such as E85 or E20 are NOT recommended for use in TecumsehPower engines. Alternative fuels with high alcohol content can cause hard starting, poor engine performance, and may cause internal engine damage.

NOTE

Damage and/or performance problems that occur from use of fuels other than those listed in the Operator's Manuals will not be considered warranty.

IV. Before Starting Your Engine

A. Checking Oil Level

To avoid engine damage, it is important to:

- Check oil level before each use and every 5 operating hours when engine is warm. Check oil level more frequently during engine break-in.
- Keep oil level between "FULL" and "ADD" marks on oil fill cap/dipstick or to point of overflow on engines with an oil fill cap/plug. See Figure 6.
- Be sure oil fill cap/dipstick or oil fill cap/plug is tightened securely.

Table 1. Recommended Oil

TecumsehPower Recommended Oil Usage										
					Straight Grade TecumsehPower Part No. 730225A or SAE 30W					
			Multi Grade TecumsehPower Part No. 730226A or SAE 5W30 or SAE 10W							
			TecumsehPower Synthetic Part No. 730263 or SAE 0W30							
	-20°F	0°F	20°F	32°F	40°F	60°F	80°F	100°F		
	-30°C	-20°C	-10°C	0°C	10°C	20°C	30°C	40°C		

Table 2. Recommended Fuel

Fuel Component	Percentage
Ethanol	10%
Grain Alcohol ("Gasohol")	10%
MTBE (Methyl Tertiary Butyl Ether)	15%
ETBE (Ethyl Tertiary Butyl Ether)	15%

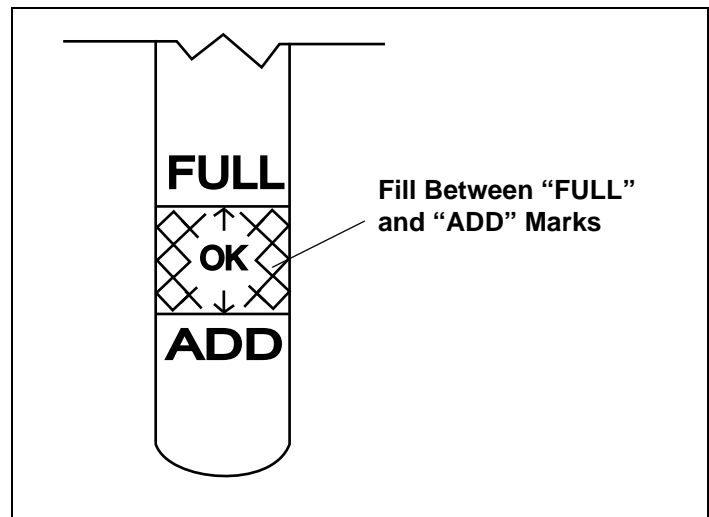

Figure 6. Engine Oil Level

NOTES

DO NOT overfill oil filler. Doing so may result in oil carry-over to the air cleaner and equipment and cause malfunction or damage.

DO NOT allow oil level to fall below the "ADD" mark on oil fill cap/dipstick. Doing so may result in equipment malfunction or damage.

Contact your Authorized TecumsehPower Servicing Dealer for TecumsehPower Oil.

Some engines are equipped with an oil fill cap/dipstick or oil fill cap/plug (see equipment manufacturer's instructions). To change the oil on your engine, see "A. Changing Oil" instructions on page 8.

B. Filling Oil Sump

1. Be sure engine is upright and level.
2. Unscrew oil fill cap/dipstick from oil filler tube and wipe dipstick clean. See Figure 7.
3. Screw oil fill cap/dipstick back into oil filler tube. Tighten securely.
4. Unscrew and remove oil fill cap/dipstick from oil filler tube. Note oil level. If oil reading on dipstick is below "ADD" mark, slowly add oil to reach "FULL" level. See Figure 6 on page 4. Afterward, continue reading instructions below.
5. Screw oil fill cap/dipstick back into oil filler tube. Tighten securely.
6. Wipe away any spilled oil.

C. Filling Fuel Tank

⚠ WARNING An adult should fuel this engine. NEVER allow children to refuel this engine. Gasoline (fuel) vapors are highly flammable and can explode. Fuel vapors can spread and be ignited by a spark or flame many feet away from engine. To prevent injury or death from fuel fires, follow these instructions:

1. Stop engine and allow it to cool before refueling.
2. Be sure engine is outdoors and in a well-ventilated area.
3. Clean area around fuel fill cap and remove fuel fill cap.

NOTE

For recommended fuel, see Table 2 and "III. Oil and Fuel Specifications" instructions on page 4. Afterward, continue reading instructions below.

4. Using an approved red GASOLINE container, add fuel slowly, being careful to avoid spilling. DO NOT overfill fuel tank. Leave space in the tank to allow fuel to expand without overflowing.
5. Replace fuel fill cap securely and wipe up spilled fuel before starting engine. If fuel is spilled DO NOT start engine. Move machine away from area of spillage. Avoid creating any source of ignition until fuel vapors are gone.

The Twin Cylinder Engines have **two** spark plug connections.

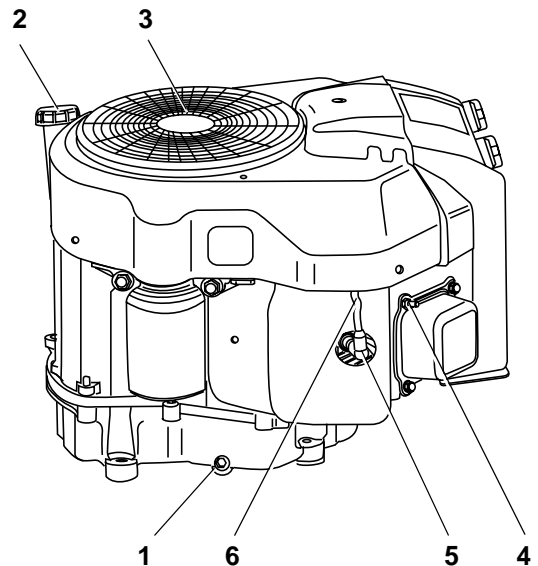

1. Oil Drain Plug
2. Oil Fill Cap/Dipstick
3. Air Intake Screen
4. Grounding Post
5. Spark Plug Cap
6. Spark Plug Wire

Figure 7. Engine with Oil Fill Cap/Dipstick

V. Starting Your Engine

WARNING To avoid serious injury or death, an adult should start this engine. Only allow children to start engine if an adult has determined they are experienced and capable of such operation.

WARNING If you are unable to start this engine after following instructions in this manual, contact your Authorized TecumsehPower Servicing Dealer. To avoid serious burn injuries or damage to your engine, DO NOT attempt to start or troubleshoot this engine in any other way. For example:

- DO NOT use starting fluid.
- DO NOT spray flammable vapors into carburetor or onto air cleaner.
- DO NOT put flammable liquids into carburetor or onto air cleaner.
- DO NOT operate engine or pull on starter rope with spark plug removed. Fuel can spray from spark plug hole and ignite.

A. Combined Speed and Choke Control

1. To avoid carbon monoxide poisoning, be sure engine is outdoors in a well-ventilated area.
2. Move combined control to “CHOKE” or “START” position (see equipment manufacturer’s instructions). See Figures 8 and 9.

NOTE

If restarting a warm engine after a short shutdown, move combined control to “FAST” instead of “CHOKE” or “START” position. See Figures 8 and 9.

3. Push starter button or turn ignition switch key (see equipment manufacturer’s instructions) to start engine.

NOTES

DO NOT operate an electric starter for more than 5 seconds each attempt.

If engine fails to start after 3 attempts repeat steps 2 thru 3.

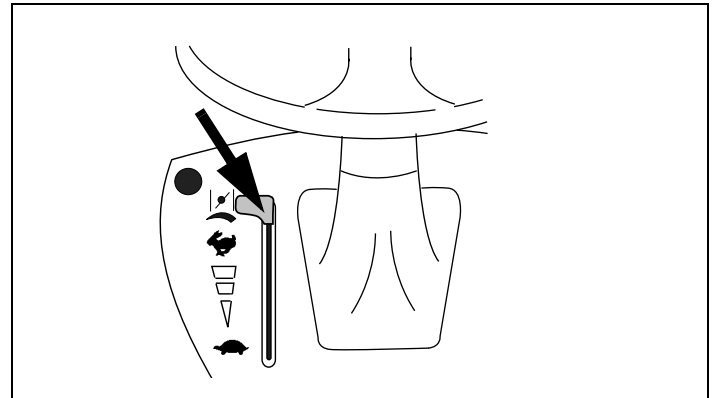

Figure 8. Combined Speed and Choke Control

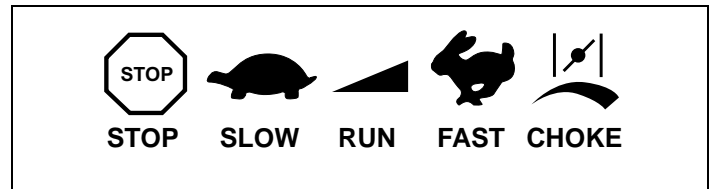

Figure 9. Typical Engine Symbols

4. When engine starts:
 - a. Release starter button or ignition switch key.
 - b. Next, move combined control to “FAST” position.
 - c. Finally, move combined control to desired speed in “RUN” range.

NOTES

If engine starts, but falters when combined control is moved to “FAST” position:

- a. *Momentarily move combined control back to “CHOKE” position.*
- b. *Next, move combined control to “FAST” position.*
- c. *Finally, move combined control to desired speed in “RUN” range.*

If engine dies after combined control is moved to “FAST” position, repeat steps 2 thru 4 to restart engine.

5. If engine fires but does NOT continue to run, move combined control to “FAST” position and then start engine.
6. If engine fails to start after 3 attempts with combined control in “FAST” position, move combined control to “CHOKE” position and push button or turn key to start engine again.
7. If engine does NOT start after following steps 1 thru 6, contact your Authorized Tecumseh Servicing Dealer. DO NOT attempt to start or troubleshoot this engine in any other way.

B. Independent Speed and Choke Controls

1. To avoid carbon monoxide poisoning, be sure engine is outdoors in a well-ventilated area.
2. Move independent speed control to “FAST” position and set independent choke control to “FULL CHOKE” position (see equipment manufacturer’s instructions). See Figures 9 thru 11 starting on page 6. Afterwards, continue reading instructions below.

NOTES

Generator and Water Pump applications may have the choke lever mounted on the engine. See Figure 12.

If restarting a warm engine after a short shutdown, move independent speed control to “FAST” position and move independent choke control to “NO CHOKE” position.

3. Push starter button or turn ignition switch key (see equipment manufacturer’s instructions) to start engine.

NOTES

DO NOT operate an electric starter for more than 5 seconds each attempt.

If engine fails to start after 3 attempts repeat steps 2 thru 3.

4. When engine starts:
 - a. Release starter button or ignition switch key.
 - b. Move independent choke control to “1/2 CHOKE” position until engine runs smoothly.
 - c. Next, move independent choke control to “NO CHOKE” position. See Figure 11.
5. Finally, move independent speed control to desired speed in “RUN” range.

NOTES

If engine starts but falters when independent choke control is moved to “NO CHOKE” position:

- a. Momentarily move independent choke control back to “FULL CHOKE” position.
- b. Next, move independent choke control to “1/2 CHOKE” position until engine runs smoothly.
- c. Finally, move independent choke control to “NO CHOKE” position.

If engine dies after independent choke control is moved to “NO CHOKE” position, repeat steps 2 thru 5 to restart engine.

6. If engine fires but does NOT continue to run, move independent choke control to “NO CHOKE” position and start engine.
7. If engine fails to start after 3 attempts in the “NO CHOKE” position, move independent choke control to “FULL CHOKE” position and start engine.
8. If engine does NOT start after following steps 1 thru 7, contact your Authorized Tecumseh Power Servicing Dealer. DO NOT attempt to start or troubleshoot this engine in any other way.

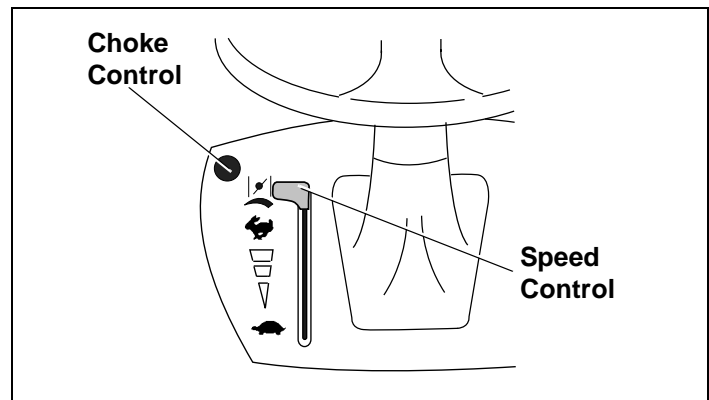

Figure 10. Independent Speed and Choke Controls

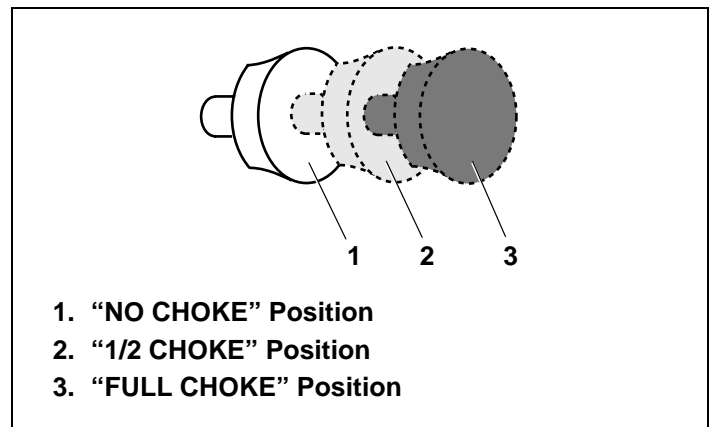

Figure 11. Choke Control Positions

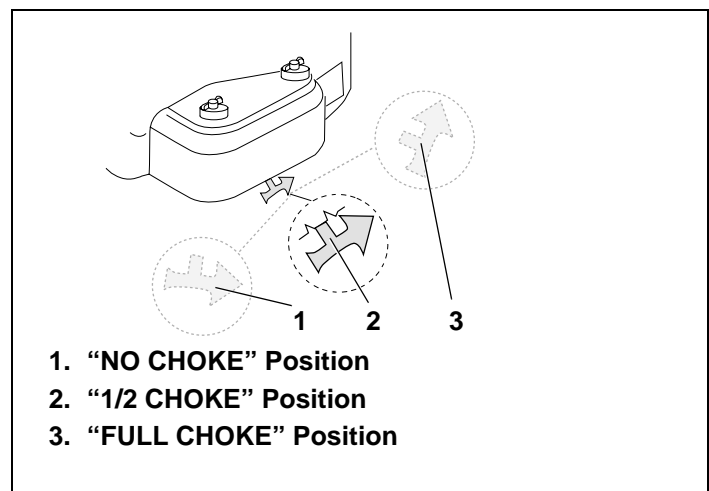

Figure 12. Engine Mounted Choke Lever

VI. Stopping Your Engine and Short-Term Storage

Stop engine according to equipment manufacturer's instructions.

WARNING To avoid unsupervised operation of an engine, especially by children, NEVER leave it unattended when it is running. Always turn off the engine after use and remove ignition key, if provided. Failure to do so may lead to serious injury or death.

WARNING NEVER store engine with fuel in the fuel tank inside a building with potential sources of ignition such as hot water or space heaters, clothes dryers, electric motors, etc. Doing so may lead to an explosion resulting in death or serious injury.

VII. Maintenance

WARNING To avoid serious injury or death, an adult should perform maintenance on this engine. Only allow children to perform maintenance if an adult has determined they are experienced and capable of such operation.

NOTE

The Twin Cylinder Engines have **two** spark plug connections.

WARNING To prevent accidental starting when working on equipment, always:

- Carefully disconnect spark plug wire and keep it away from spark plug. See "G. Avoid Accidental Starts" instructions on page 2. Afterward, continue reading instructions below.
 - Keep the disconnected spark plug wire securely away from metal parts where arcing could occur.
 - Carefully attach the spark plug wire to the grounding post, if provided.
- Disconnect battery at negative terminal first, if engine is equipped with a DC electric starter.
- Turn all engine switches to "OFF" position.
- Remove ignition key, if provided.

A. Changing Oil

To avoid engine damage, it is important to:

- Check oil level before each use and every 5 operating hours when engine is warm. See "A. Checking Oil Level" instructions on page 4. Afterward, continue reading instructions below.
- Change oil after first 2 operating hours and every 50 operating hours thereafter; more often if operated in extremely dusty or dirty conditions. Engine should still be warm but NOT hot from recent use.

NOTE

The Twin Cylinder Engines have **two** spark plug connections.

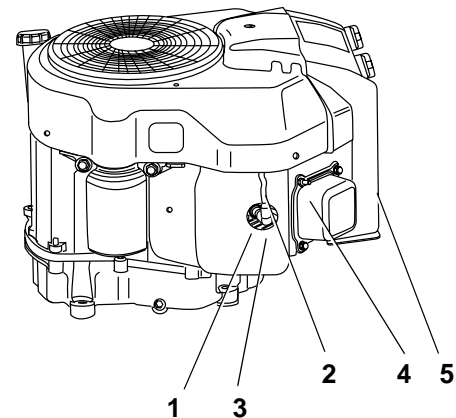
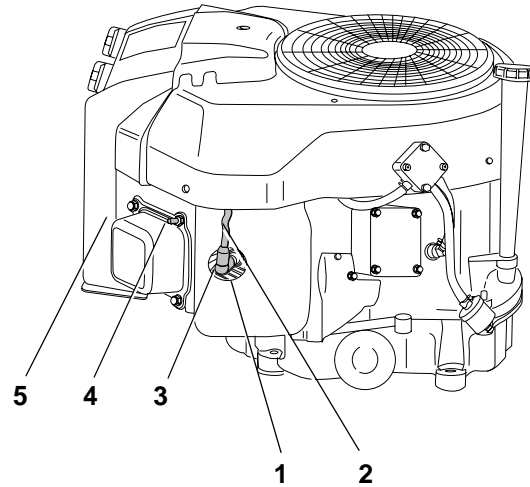

1. Spark Plug
2. Spark Plug Wire
3. Spark Plug Cap
4. Grounding Post
5. Front Orientation of Engine

Figure 13. Spark Plug Locations

1. Be sure you find the correct drain plug location, if present (see equipment manufacturer's instructions). See Figure 14 on page 9. Afterward, continue reading instructions below.

NOTE

The Twin Cylinder Engines have **two** spark plug connections.

2. Carefully disconnect spark plug wires and keep them away from spark plugs. See "G. Avoid Accidental Starts" instructions on page 2. Afterward, continue reading instructions below.
3. Be sure the fuel fill cap is on and is tightened securely.

4. Clean area around oil drain plug. See Figure 14.
5. Place approved recyclable oil container under oil drain plug (see equipment manufacturer's instructions).

NOTE

Used oil must be disposed of at a proper collection center.



6. Remove oil drain plug and drain oil into an approved recyclable oil container.
7. Install oil drain plug and tighten securely.
8. Fill with recommended oil. See "III. Oil and Fuel Specifications" instructions and Table 1 on page 4. See Figure 15. Afterward, continue reading instructions below.
9. Wipe away any spilled oil.
10. Carefully disconnect spark plug wires from grounding posts, if provided.
11. Connect spark plug wires to spark plugs before attempting to start engine. See Figure 13 on page 8. Afterward, continue reading instructions below.

NOTES

The oil filter if so equipped, should be changed every 100 operating hours or at least once a year.

The filter should be changed more often if the engine is operated in extremely dusty or dirty conditions.

Changing the oil filter requires that additional oil be added to fill the filter.

Contact your Authorized TecumsehPower Servicing Dealer for a genuine replacement Oil Filter.

B. Removing Debris from Engine

Before each use, remove grass clippings, dirt and debris from the following areas:

- Levers and Linkage
- Cooling Fins
- Air Intake Screen
- Guards

Removing debris will insure adequate cooling, correct engine speed and reduce the risk of fire.

NOTES

Before removing air cleaner cover, see "I. Servicing Foam Pre-Filter" instructions on page 10 and/or "II. Servicing Paper Filters" instructions on page 11. Special care should be taken to prevent damage when removing air cleaner cover. See Figure 17 on page 10. Afterward, continue reading instructions below.

DO NOT bend levers and linkage with fingers.

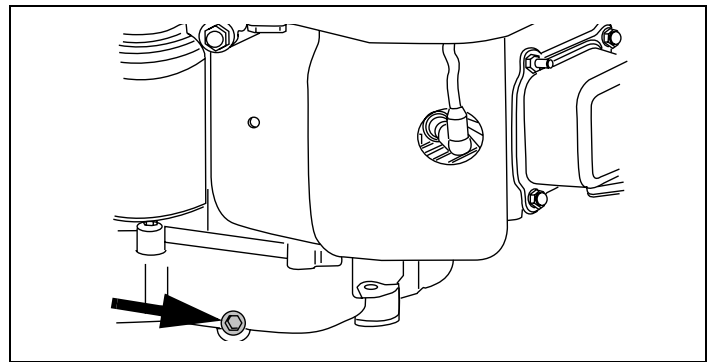
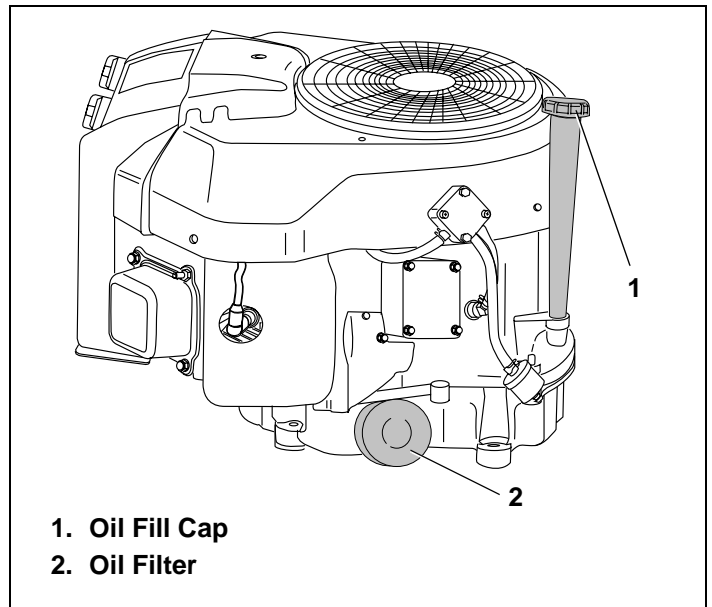

Figure 14. Oil Drain Plug Location



1. Oil Fill Cap
2. Oil Filter

Figure 15. Oil Fill Cap and Oil Filter Location

1. Remove air cleaner cover and filters. See Figure 17 on page 10.
2. Remove debris from air inlet, air cleaner cover and air intake screen.
3. Inspect filter(s) for discoloration or dirt accumulation. If either is present, see "I. Servicing Foam Pre-Filter" instructions on page 10 and/or "II. Servicing Paper Filters" instructions on page 11. Afterward, continue reading instructions below.
4. Replace air cleaner cover and filters.

C. Spark Plug

NOTE

The Twin Cylinder Engines have **two** spark plug connections.

Check both spark plugs yearly or every 100 operating hours.

1. Clean area around spark plug.
2. Remove and inspect spark plug.
3. Replace spark plug if porcelain is cracked or if electrodes are:
 - Pitted
 - Burned
 - Fouled with Deposits
4. Check electrode gap with wire feeler gauge and set gap to—.030 (0.76 mm) if necessary. See Figure 16.
5. Install spark plug and tighten securely.

NOTE

A resistor spark plug must be used for replacement. Contact your Authorized TecumsehPower Servicing Dealer for a genuine replacement Resistor Spark Plug.

D. Cleaning/Replacing Air Cleaner

Your engine has an air cleaner which helps prevent premature engine wear and failure. NEVER run engine without complete air cleaner installed on engine. Your air cleaner periodically needs to be cleaned or replaced.

NOTES

ALWAYS inspect filter(s) for discoloration or dirt accumulation. If either is present, see "I. Servicing Foam Pre-Filter" instructions on this page and/or "II. Servicing Paper Filters" instructions on page 11.

Contact your Authorized TecumsehPower Servicing Dealer for a genuine replacement Air Cleaner.

I. Servicing Foam Pre-Filter

Clean foam pre-filter every 3 months or every 25 operating hours. Clean daily if used in extremely dusty conditions. After removing the pre-filter, follow these cleaning instructions below:

1. Wash in warm water and detergent solution then press (DO NOT twist) until all dirt is removed.
2. Rinse thoroughly until water is clear.
3. Wrap in a clean cloth and press (DO NOT twist) until completely dry.

NOTE

DO NOT oil foam pre-filter.

4. Replace foam pre-filter onto paper filter.

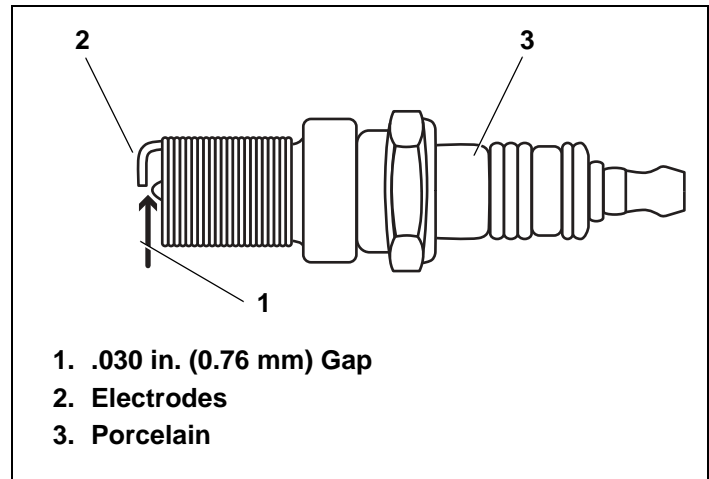

Figure 16. Resistor Spark Plug

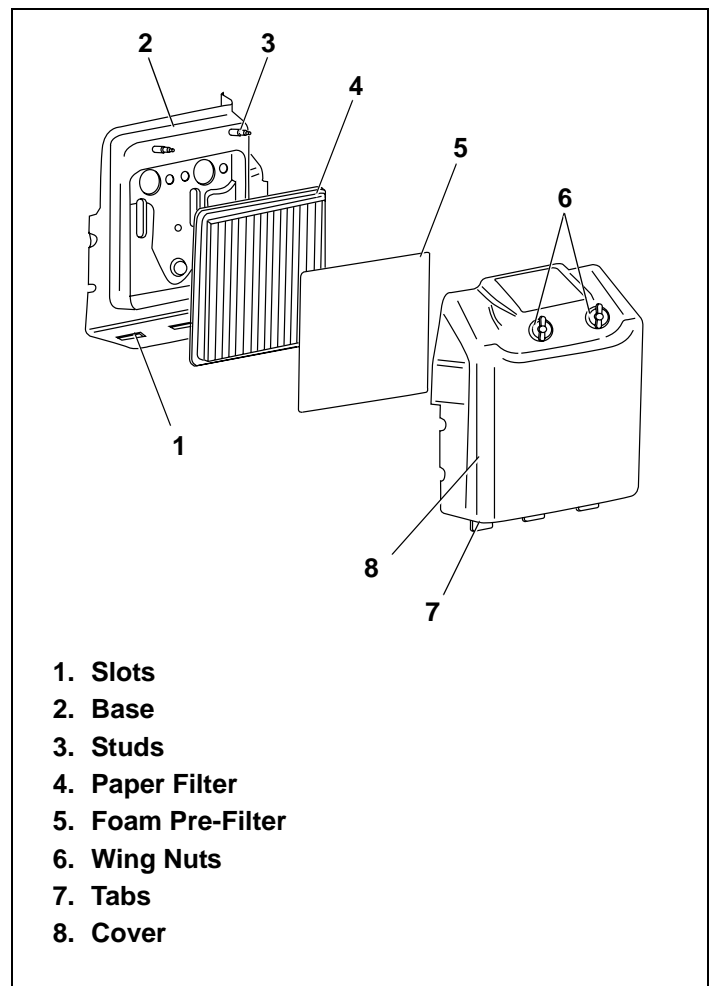

Figure 17. Air Cleaner Components

II. Servicing Paper Filters

Paper filters cannot be cleaned and must be replaced once a year or every 100 operating hours; more often if used in extremely dusty conditions. Replacement filters are available at an Authorized TecumsehPower Servicing Dealer.

NOTE

DO NOT put oil on or clean a paper filter.

III. Filter Removal/Installation

1. Remove wing nuts from air cleaner cover. See Figure 17 on page 10. Afterward, continue reading instructions below.
2. Remove air cleaner cover while lifting upward then outward.
3. Remove and inspect filter(s) for discoloration or dirt accumulation. If either is present, see "I. Servicing Foam Pre-Filter" instructions on page 10 and/or "II. Servicing Paper Filters" instructions. Afterward, continue reading instructions below.
4. Clean inside of cover and body thoroughly.
5. Install paper filter (see equipment manufacturer's instructions).

NOTE

Wire mesh side of paper filter must face air cleaner base.

6. Install foam pre-filter (see equipment manufacturer's instructions).
7. Install cover.
 - a. Push cover inward onto base.
 - b. Lock tabs into slots on base.
 - c. Push down onto cover.
8. Install wing nuts and tighten securely.

E. Carburetor

If you think your carburetor needs adjusting, see your nearest Authorized TecumsehPower Servicing Dealer. Engine performance should not be affected at altitudes up to 7,000 feet (2,134 meters). For operation at higher elevations, contact an Authorized TecumsehPower Servicing Dealer.

F. Engine Speed



WARNING

To avoid serious injury or death, DO NOT modify engine in any way.

Tampering with the governor setting can lead to a runaway engine and cause it to operate at unsafe speeds. NEVER tamper with factory setting of engine governor.

Running the engine faster than the speed set at the factory can be dangerous and will **VOID THE ENGINE WARRANTY.**

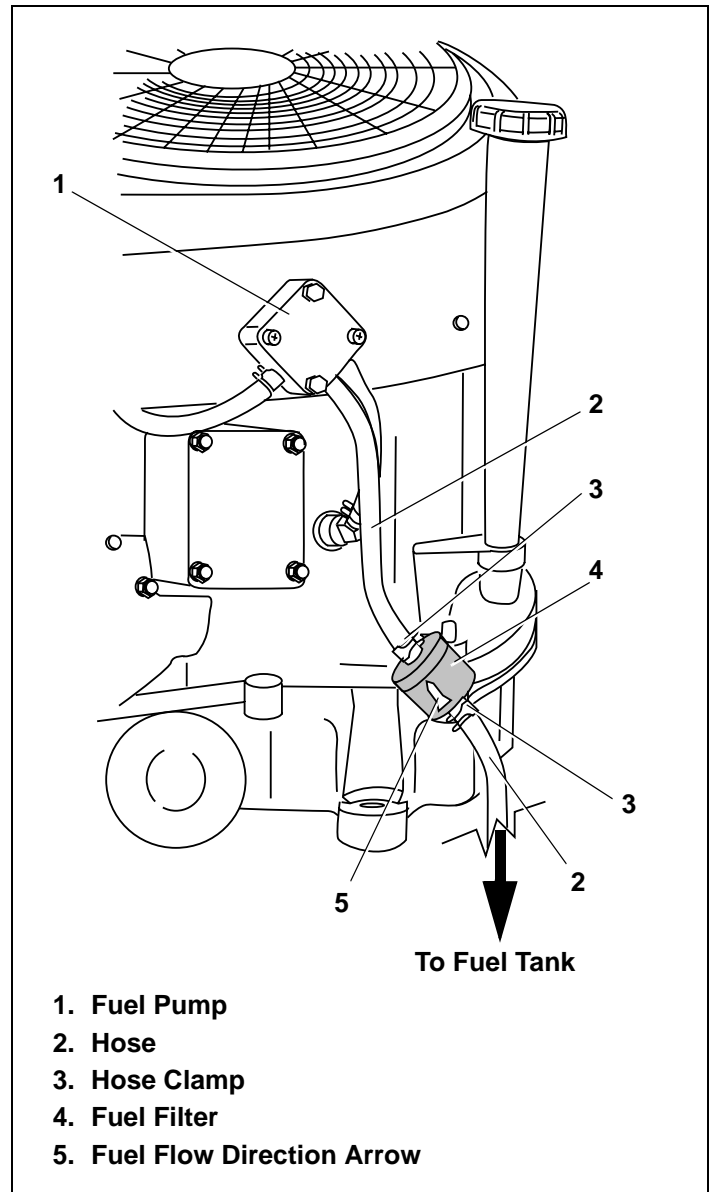

Figure 18. Replacing Fuel Filter

G. Adjustments

DO NOT make any engine adjustments. Factory settings are satisfactory for most conditions. If adjustments are needed, contact your Authorized TecumsehPower Servicing Dealer.

H. Fuel Filter Removal/Installation

1. Remove hose clamp on hose. See Figure 18.
2. Slide hose clamp away from filter; repeat for other clamp.
3. Remove hoses from fuel filter.
4. Place hoses on both ends of new fuel filter.
5. Slide hose clamp toward filter; repeat for other clamp.
6. Install hose clamp; repeat for other hose.

VIII. Transporting Your Engine

 **WARNING** NEVER transport this engine inside another vehicle or in any enclosed space if there is any gasoline in the tank. Fuel vapor or spilled fuel may ignite leading to serious injury or death.

If there is fuel in the fuel tank, close the fuel shut-off valve, if equipped, and transport the engine upright in an open vehicle, such as an open trailer or open bed of a pickup truck.

If you DO NOT have an open vehicle and have to transport the engine upright in a closed vehicle, follow these steps for emptying the fuel tank before transporting:

1. Empty fuel tank by using a commercially available suction device designed for use with gasoline.

 **WARNING** To avoid serious injury or death, DO NOT pour fuel from engine or siphon fuel by mouth.

2. Drain fuel into an approved red GASOLINE container, being careful to avoid spilling.
3. Run the engine until remaining fuel is consumed.

 **WARNING** NEVER leave the engine unattended when it is running and NEVER run engine in enclosed areas to avoid death or serious injury.

IX. Storing Your Engine

A. Short-Term/Seasonal Storage

I. Clean Engine

Before servicing the engine remove the air cleaner cover and/or blower housing. Remove grass clippings, dirt and debris from the following areas:

- Cooling Fins
- Air Intake Screen
- Levers
- Linkage
- Guards
- Carburetor
- Head

Removing debris will insure adequate cooling, correct engine speed and reduce the risk of fire.

II. Fuel Storage

 **WARNING** NEVER store engine with fuel in the fuel tank inside a building with potential sources of ignition such as hot water or space heaters, clothes dryers, electric motors, etc. Doing so may lead to an explosion resulting in death or serious injury.

NOTES

If engine fuel stored in the gas tank and/or an approved gas container is to be unused without gasoline stabilizer for more than 15-30 days, prepare it for short-term/seasonal storage. See "IV. Fuel Treatment" instructions. Afterward, continue reading instructions below.

*If engine fuel is to be stored for more than one season, without gasoline stabilizer, it will gradually deteriorate. Also, if it is stored in the engine's gas tank without gasoline stabilizer it is likely that your carburetor will have gum deposits, a clogged fuel system and **WILL VOID YOUR WARRANTY**. Prepare the fuel for extended storage. See "B. Extended Storage" instructions on page 13. Afterward, continue reading instructions below.*

III. Fuel System

To avoid stale gas and carburetor problems, treat the fuel system in the following method below:

NOTES

TecumsehPower Company recommends using ULTRA-FRESH™ Gasoline Stabilizer as an acceptable method of minimizing formation of fuel gum deposits during storage. This product is available from your Authorized TecumsehPower Servicing Dealer.

Always follow mix ratio found on stabilizer container. Failure to do so may result in equipment damage.

It is NOT necessary to drain stabilized gas from carburetor.

IV. Fuel Treatment

1. Add fuel stabilizer according to manufacturer's instructions.
2. Run engine at least 10 minutes after adding stabilizer to allow it to reach carburetor.

 **WARNING** NEVER store engine with fuel in the fuel tank inside a building with potential sources of ignition such as hot water or space heaters, clothes dryers, electric motors, etc. Doing so may lead to an explosion resulting in death or serious injury.

NOTE

Instead of using a fuel preservative/stabilizer, you can empty the fuel tank as described under "I. Draining Fuel" instructions on page 13. See "B. Extended Storage" instructions.

B. Extended Storage

I. Draining Fuel

NOTES

Clean debris from engine before draining fuel from carburetor. See "I. Clean Engine" instructions on page 12. Afterward, continue reading instructions below.

If you have prepared your fuel for short-term storage it is NOT necessary to drain fuel that contains stabilizer from your carburetor. See "A. Short-Term/Seasonal Storage" instructions on page 12. Afterward, continue reading instructions below.

WARNING

To avoid serious injury or death, DO NOT pour fuel from engine or siphon fuel by mouth.

1. To prevent serious injury from fuel fires, empty fuel tank by running engine until it stops from lack of fuel. DO NOT attempt to pour fuel from engine.
2. Run the engine while waiting until the remaining fuel is consumed.

WARNING

NEVER leave the engine unattended when it is running and NEVER run engine in enclosed areas to avoid death or serious injury.

3. Begin servicing the cylinder bore. See "II. Oil Cylinder Bore" instructions.

NOTE

If you operate the engine during all four seasons, it is NOT necessary to lubricate the cylinder bore.

II. Oil Cylinder Bore

CAUTION

When lubricating cylinder bore, fuel may spray from spark plug hole. To prevent serious injury from fuel fires, follow these instructions:

1. Carefully disconnect spark plug wires and keep them away from spark plugs. See Figures 19 and 20.
 - Keep the disconnected spark plug wires securely away from metal parts where arcing could occur.
 - Carefully attach the spark plug wires to the grounding posts, if provided.
- Disconnect battery at negative terminal first, if engine is equipped with a DC electric starter.
- Turn all engine switches to "OFF" position.
- Remove ignition key, if provided.
2. Remove spark plugs.
3. Squirt 1oz. (30 ml) of clean engine oil into spark plug holes.
4. Cover spark plug holes with rags to prevent fuel from spraying from spark plug holes when starter is engaged.
5. Push starter button or turn ignition switch key to "START" position. Immediately release starter button or turn ignition switch key to "OFF" position (this will distribute oil throughout the cylinders to prevent corrosion during storage).
6. Remove rags covering spark plug holes.
7. Install spark plugs.
8. Carefully disconnect spark plug wires from grounding posts, if provided.
9. Connect spark plug wires to spark plugs before attempting to start engine.

III. Oil

Change oil if NOT changed within the last 3 months. See "A. Changing Oil" instructions on page 8.

IV. Battery

See equipment manufacturer's instructions for proper battery storage, if machine is equipped with a battery.

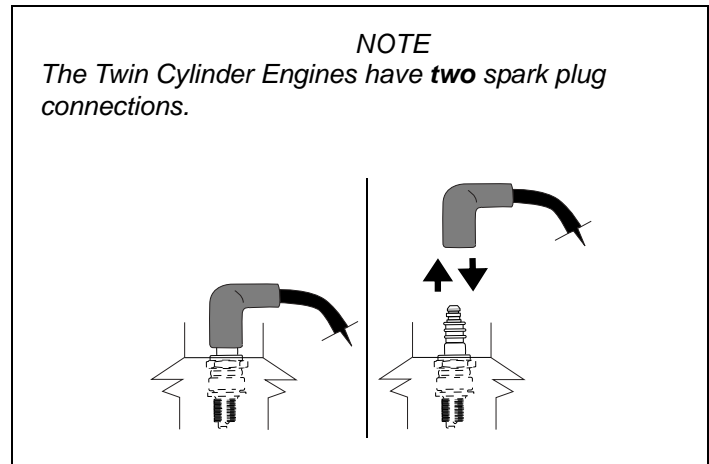

Figure 19. Disconnecting/Connecting Spark Plug

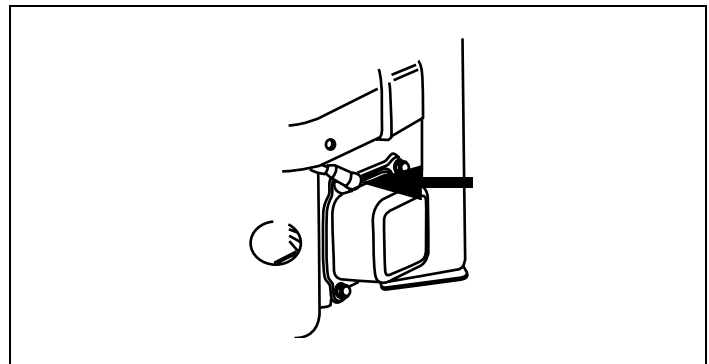

Figure 20. Typical Spark Plug Grounding Post

X. Preventing Forest, Brush and Grass Fires

Local, state and federal laws may require use of a spark arrester to prevent fires. For example, it is a violation of California Public Resources Code (section 4442) to use or operate engine on any forest-covered, brush-covered or unimproved grass-covered land unless engine is equipped with a spark arrester. Spark arrester must be maintained in effective working order by owner and/or operator.

To determine if your engine has a spark arrester, locate the muffler on your engine. For example, the muffler discharge will have a spark arrester cover that reads "Screen Type 36085".

If your engine does NOT have a spark arrester, you may purchase one from your Authorized TecumsehPower Servicing Dealer. In some cases the muffler may need to be replaced to allow the spark arrester to be installed.

XI. Maintenance Intervals

Maintenance is one of the most important things that you can do to extend the life of your TecumsehPower engine. If you are unable to perform maintenance intervals yourself, contact your nearest Authorized TecumsehPower Servicing Dealer. Find them on our website at www.TecumsehPower.com or call TecumsehPower Company at 1-800-558-5402 for additional information.

ALWAYS promptly follow maintenance intervals listed in this manual. See Table 3.

Table 3. Maintenance Intervals

Procedure	Time
Change Oil	After First 2 Hours When Engine is Warm
Check Oil Level	Every 5 Hours or Before Each Use
Clean Cooling Fins	Every 5 Hours or Before Each Use
Clean Foam Pre-Filter	Every 25 Hours or 3 Months
Change Oil	Every 50 Hours or 3 Months
Replace Paper and Oil Filter	Every 100 Hours or Seasonally
Check Spark Plugs	Every 100 Hours or Seasonally
Replace Spark Plugs	Every 200 Hours or Seasonally

Scheduled Maintenance

After First 2 Hours When Engine is Warm

1. Change Oil

Date _____ Owner/Dealer

CALIFORNIA & US EPA EMISSION CONTROL WARRANTY STATEMENT

The U. S. Environmental Protection Agency ("EPA"), the California Air Resources Board ("CARB") and TecumsehPower Company are pleased to explain the Federal and California Emission Control Systems Warranty on your new small off-road engine. In California, new 1995 and later small off-road engines must be designed, built and equipped to meet the State's stringent anti-smog standards. In other states, new 1997 and later model year engines must be designed, built and equipped, at the time of sale, to meet the U.S. EPA regulations for small non-road engines. TecumsehPower Company will warrant the emission control system on your small off-road engine for the periods of time listed below, provided there has been no abuse, neglect, unapproved modification, or improper maintenance of your small off-road engine.

Your emission control system may include parts such as the carburetor, air cleaner assembly, ignition system, exhaust system, crankcase breather assembly and, the evaporative control system. Also included may be the compression release system and other emission-related assemblies.

Where a warrantable condition exists, TecumsehPower Company will repair your small off-road engine at no cost to you for diagnosis, parts and labor.

MANUFACTURER'S EMISSION CONTROL SYSTEM WARRANTY COVERAGE

Emission control systems on 1995 and later model year California small off-road engines are warranted for two years as hereinafter noted. In other states, 1997 and later model year engines are also warranted for two years. If, during such warranty period, any emission-related part on your engine is defective in materials or workmanship, the part will be repaired or replaced by TecumsehPower Company.

OWNER'S WARRANTY RESPONSIBILITIES

As the small off-road engine owner, you are responsible for the performance of the required maintenance listed in your Operator's Manual, but TecumsehPower Company will not deny warranty solely due to the lack of receipts or for your failure to provide written evidence of the performance of all scheduled maintenance.

As the small off-road engine owner, you should, however, be aware that TecumsehPower Company may deny you warranty coverage if your small off-road engine or a part thereof has failed due to abuse, neglect, improper maintenance or unapproved modifications.

You are responsible for presenting your small off-road engine to a TecumsehPower Authorized Service Outlet

(any TecumsehPower Registered Service Dealer, TecumsehPower Authorized Service Distributor or TecumsehPower Central Warehouse Distributor) as soon as a problem exists. The warranty repairs should be completed in a reasonable amount of time, not to exceed 30 days.

Warranty service can be arranged by contacting either an Authorized TecumsehPower Servicing Dealer and/or TecumsehPower Company, c/o Service Manager, 900 North Street, Grafton, WI 53024-1499. Telephone 1-262-377-2700 [or in USA/Canada call 1-800-558-5402].

IMPORTANT NOTE

This warranty statement explains your rights and obligations under the Emission Control System Warranty ("ECS Warranty") which is provided to you by TecumsehPower Company pursuant to California law. TecumsehPower Company also provides to original purchasers of new TecumsehPower engines the TecumsehPower Company Limited Warranties for New TecumsehPower Engines and Electronic Ignition Modules. The TecumsehPower Company Limited Warranties for New TecumsehPower Engines and Electronic Ignition Modules ("TecumsehPower Company Warranty") are located on the back cover of the Operator's Manual, enclosed with all new TecumsehPower engines. The ECS Warranty applies only to the emission control system of your new engine. To the extent that there is any conflict in terms between the ECS Warranty and the TecumsehPower Company Warranty, the ECS Warranty shall apply except in any circumstances in which the TecumsehPower Company Warranty may provide a longer warranty period. Both the ECS Warranty and the TecumsehPower Company Warranty describe important rights and obligations with respect to your new engine.

Warranty service can only be performed by a TecumsehPower Authorized Servicing Dealer. At the time of requesting warranty service, evidence must be presented of the date of sale to the original purchaser. The purchaser shall pay any charges for making service calls and/or for transporting the products to and from the place where the inspection and/or warranty work is performed. The purchaser shall be responsible for any damage or loss incurred in connection with the transportation of any engine or any part(s) thereof submitted for inspection and/or warranty work.

If you have any questions regarding your warranty rights and responsibilities, you should contact TecumsehPower Company at 1-262-377-2700 or in USA/Canada call 1-800-558-5402.

Revised February 2008

IMPORTANT!

The Emission Regulations may be different for your country. The Emissions Control Warranty Statement is only applicable to engines with an emissions compliance statement and decal that references "Emissions Regulations".

EMISSION CONTROL SYSTEM WARRANTY

Emission Control System Warranty ("ECS Warranty") for 1995 and later model year California small off-road engines (for other states, 1997 and later model year engines):

A. APPLICABILITY: This warranty shall apply to 1995 and later model year California small off-road engines (for other states, 1997 and later model year engines). The ECS Warranty Period shall begin on the date the new engine or equipment is delivered to its original, end-use purchaser, and shall continue for 24 consecutive months thereafter.

B. GENERAL EMISSIONS WARRANTY COVERAGE:

TecumsehPower Company warrants to the original, end-use purchaser of the new engine or equipment and to each subsequent purchaser that each of its small off-road engines is:

1. Designed, built and equipped so as to conform with all applicable regulations adopted by the Air Resources Board pursuant to its authority in Chapters 1 and 2, Part 5, Division 26 of the Health and Safety Code, and
2. Free from defects in materials and workmanship which, at any time during the ECS Warranty Period, will cause a warranted emissions-related part to fail to be identical in all material respects to the part as described in the engine manufacturer's application for certification.

C. THE ECS WARRANTY ONLY PERTAINS TO EMISSION-RELATED PARTS ON YOUR ENGINE AS FOLLOWS:

1. Any warranted, emissions-related parts which are not scheduled for replacement as required maintenance in the Operator's Manual shall be warranted for the ECS Warranty Period. If any such part fails during the ECS Warranty Period, it shall be repaired or replaced by TecumsehPower Company according to Subsection 4 below. Any such part repaired or replaced under the ECS Warranty shall be warranted for any remainder of the ECS Warranty Period.
2. Any warranted, emissions-related part which is scheduled only for regular inspection as specified in the Operator's Manual shall be warranted for the ECS Warranty Period. A statement in such written instructions to the effect of "repair or replace as necessary", shall not reduce the ECS Warranty Period. Any such part repaired or replaced under the ECS Warranty shall be warranted for the remainder of the ECS Warranty Period.
3. Any warranted, emissions-related part which is scheduled for replacement as required maintenance in the Operator's Manual, shall be warranted for the period of time prior to the first scheduled replacement point for that part. If the part fails prior to the first scheduled replacement, the part shall be repaired or replaced by TecumsehPower Company according to Subsection 4 below. Any such emissions-related part repaired or replaced under the ECS Warranty, shall be warranted for the remainder of the ECS Warranty Period prior to the first scheduled replacement point for such emissions-related part.
4. Repair or replacement of any warranted, emissions-related part under this ECS Warranty shall be performed at no charge to the owner at a TecumsehPower Authorized Service Outlet.

5. The owner shall not be charged for diagnostic labor which leads to the determination that a part covered by the ECS Warranty is in fact defective, provided that such diagnostic work is performed at a TecumsehPower Authorized Service Outlet.

6. TecumsehPower Company shall be liable for damages to other original engine components or approved modifications proximately caused by a failure under warranty of an emission-related part covered by the ECS Warranty.

7. Throughout the ECS Warranty Period, TecumsehPower Company shall maintain a supply of warranted emission-related parts sufficient to meet the expected demand for such emission-related parts.

8. Any TecumsehPower Company authorized and approved emission-related replacement part may be used in the performance of any ECS Warranty maintenance or repair and will be provided without charge to the owner. Such use shall not reduce TecumsehPower Company ECS Warranty obligations.

9. Unapproved add-on or modified parts may not be used to modify or repair a TecumsehPower engine. Such use voids this ECS Warranty and shall be sufficient grounds for disallowing an ECS Warranty claim. TecumsehPower Company shall not be liable hereunder for failures of any warranted parts of a TecumsehPower engine caused by the use of such an unapproved add-on or modified part.

EMISSION-RELATED PARTS INCLUDE THE FOLLOWING:

1. Carburetor Assembly including internal components:
 - a) Carburetor gaskets
 - b) Intake pipe
2. Air Cleaner Assembly including components:
 - a) Air filter element
3. Ignition System including components:
 - a) Spark plug
 - b) Ignition module
 - c) Flywheel assembly
4. Exhaust System including components:
 - a) Catalytic muffler (*if so equipped*)
 - b) Muffler gasket (*if so equipped*)
 - c) Exhaust manifold (*if so equipped*)
5. Crankcase Breather Assembly including components
 - a) Breather connection tube
6. Evaporative Control System including components:
 - a) Fuel line(s)
 - b) Fuel filter
 - c) Canister (*if so equipped*)
 - d) Fuel tank (*if so equipped*)
 - e) Fuel fill cap (*if so equipped*)

Revised February 2008

IMPORTANT!

The Emission Regulations may be different for your country. The Emissions Control Warranty Statement is only applicable to engines with an emissions compliance statement and decal that references "Emissions Regulations".

XII. Warranty Information

LIMITED WARRANTY FOR NEW TECUMSEHPower ENGINES AND ELECTRONIC IGNITION MODULES

For the time period shown below from the date of purchase and subject to the exceptions and limitations described herein, TecumsehPower Company will, at its option as the exclusive remedy, either repair or replace for the original purchaser, free of charge, any part of any new TecumsehPower engine which is found, upon examination by any Authorized TecumsehPower Servicing Outlet or by TecumsehPower's Service Division, to be **DEFECTIVE IN MATERIAL AND/OR WORKMANSHIP**. This Limited Warranty **DOES NOT COVER** (i) any TecumsehPower engine or part(s) thereof used to power any vehicle in competitive racing and/or used on any commercial or rental track, or (ii) defects or damage caused by alterations or modifications of new TecumsehPower engines or parts or by normal wear, accidents, improper maintenance, improper use or abuse of the product, or failure to follow the instructions contained in an Instruction Manual for the operation of the new TecumsehPower engine or part. The cost of normal maintenance or replacement of service items which are not defective shall be paid for by the original purchaser. At the time warranty service is requested, evidence must be presented of the date of purchase by the original purchaser. Any charge for making service calls and/or for transporting any engine or part(s) thereof to and from the place where the inspection and/or warranty work is performed is payable solely by the purchaser. The purchaser is responsible for any damage or loss incurred in connection with the transportation of any engine or part(s) thereof submitted for inspection and/or warranty work. **WARRANTY SERVICE CAN ONLY BE PERFORMED BY A TECUMSEHPower AUTHORIZED SERVICE OUTLET.** Warranty service can be arranged by contacting a TecumsehPower Authorized Service Outlet (any TecumsehPower Registered Service Dealer, TecumsehPower Authorized Service Distributor, or TecumsehPower Central Warehouse Distributor) or by contacting TecumsehPower Company c/o Service Manager, 900 North Street, Grafton, Wisconsin USA 53024-1499.

Warranty Category ⁽⁶⁾	"CONSUMER USE" ⁽⁴⁾		"COMMERCIAL USE" ⁽⁵⁾	
	Within U.S.A. and Canada	Outside U.S.A. and Canada	Within U.S.A. and Canada	Outside U.S.A. and Canada
(A)	90 Day	90 Day ⁽¹⁾	No Warranty	No Warranty
(B)	1 Year	1 Year ⁽¹⁾	1 Year	1 Year
(C)	2 Years	1 Year ⁽¹⁾	1 Year	1 Year
(D)	2 Years	2 Years ⁽²⁾	1 Year	1 Year
(E)	2 Years	2 Years	1 Year	1 Year
(H)	2 'n 10 ⁽³⁾	2 'n 10 ⁽³⁾	1 Year	1 Year
(K)	2 'n 10 ⁽³⁾	2 'n 10 ⁽³⁾	2 'n 10 ⁽³⁾	1 Year
(M) ⁽⁷⁾	3 Years	3 Years	1 Year	1 Year

- (1) 2 years for Member States of the European Union. Consumers may have additional legal rights not affected by the terms of this warranty pursuant to EU Directive 1999/44/EC and the national legislation of certain Member States of the European Union.
- (2) 1 year for Australian/New Zealand for rotary mower engines.
- (3) 2 years on engine and 10 years (the first 5 years covering parts and labor only; the second 5 years covering parts only) on electronic ignition.
- (4) For purposes of this warranty policy, "consumer use" shall mean consumer's personal, residential, household use by the original retail purchaser.
- (5) For purposes of this warranty policy, "commercial use" shall mean all other uses, including use for commercial, income producing, or rental purposes.
- (6) The engine warranty category of your engine can be determined by review of the engine model number on the "Important Engine Information" decal. One letter in the engine model number will be surrounded by parenthesis (A), (B), (C), (D), (E), (H) (K) or (M) and that letter is your engine warranty category designation.
- (7) Qualification for three (3) year consumer use warranty under engine warranty category (M) may be determined by notation of an (M) designation on the "Important Engine Information" decal located on the engine housing or an addendum decal affixed adjacent thereto.

THIS EXPRESS WARRANTY IS SUPPLEMENTED BY THE TECUMSEHPower CALIFORNIA EMISSION CONTROL WARRANTY STATEMENT, if any.

THIS EXPRESS WARRANTY IS IN LIEU OF ALL OTHER EXPRESS WARRANTIES. Neither TecumsehPower Company nor any of its affiliates makes any warranties, representations, or promises, written or oral, as to the quality of the engine or any of its parts, other than as set forth herein. **ANY IMPLIED WARRANTY OF MARKETABILITY, MERCHANTABILITY, OR FITNESS FOR A PARTICULAR PURPOSE, TO THE EXTENT THAT EITHER MAY APPLY TO ANY TECUMSEHPower ENGINE OR PART(S) THEREOF, SHALL BE LIMITED IN DURATION TO THE PERIODS OF THE EXPRESS WARRANTIES SHOWN IN THE WARRANTY PERIOD CHART ABOVE AND TO THE EXTENT PERMITTED BY LAW ANY AND ALL IMPLIED WARRANTIES ARE EXCLUDED. IN NO EVENT WILL TECUMSEHPower COMPANY BE LIABLE FOR ANY INDIRECT, INCIDENTAL, CONSEQUENTIAL OR SPECIAL DAMAGES AND/OR EXPENSES, INCLUDING, BUT NOT LIMITED TO, ANY LOSS OF TIME, INCONVENIENCE, LOSS OF UNIT USE OR ANY COST OR EXPENSE OF SUBSTITUTE UNITS DURING PERIODS OF MALFUNCTION OR NON-USE.** Some states do not allow limitations on how long an implied warranty lasts or the exclusion or limitation of incidental or consequential damages, so the above limitation(s) or exclusion(s) may not apply to you. This Limited Warranty gives you specific legal rights and you may also have other legal rights which vary from state-to-state.

TecumsehPower Company neither assumes nor authorizes any other person, natural or corporate, to assume for TecumsehPower Company any other obligations or liabilities in connection with or with respect to any TecumsehPower product or parts. The seller or dealer of a TecumsehPower product or part has no authority, whatsoever, to make any representations or promises on behalf of TecumsehPower Company or to modify the terms or limitations of TecumsehPower's warranty in any way.

Revised February 2008

WARNING CALIFORNIA PROPOSITION 65

The engine exhaust from this product contains chemicals known to the State of California to cause cancer, birth defects or other reproductive harm.



TecumsehPower Company • Grafton, Wisconsin 53024-1499 • USA

Telephone: 1-800-558-5402

Visit us at: www.TecumsehPower.com

Tecumseh Parts

181-1273-14
(English) 7/01/08