



**PARTS CATALOGUE**

**ECHO  
CHAIN SAW  
CS-302S**

OCCASIONAL USER SAW

S/N 30501 - 64670



1

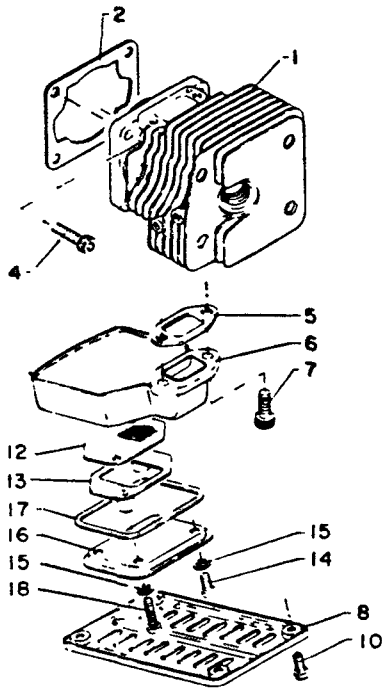

Key No.	Part No.	Q'ty	Description
1- 1	101 011-1333 0	1	Cylinder
2	101 010-1333 0	1	Cylinder packing
4	900 162-0502 0	4	H.S.H bolt 5×20
5	145 510-0393 0	1	Muffler gasket
6	145 806-0393 2	1	Muffler
7	900 105-0501 5	2	H.S.H bolt 5×15
8	145 621-0393 0	1	Muffler cover
10	900 241-0401 0	4	Screw 4×10
12	145 862-0393 0	1	Screen
13	145 905-0393 1	1	Screen retainer
14	900 220-0400 6	2	Screw 4×6
15	900 610-0000 4	4	Lock washer
16	145 861-0393 1	1	Muffler lid
17	145 866-0393 0	1	Packing
18	900 220-0401 4	2	Screw

2

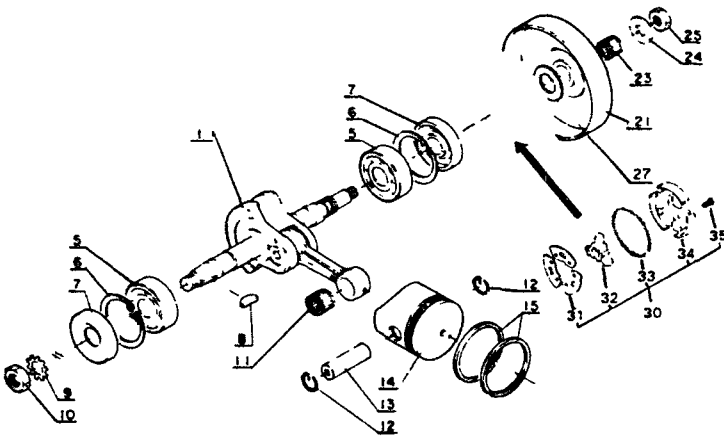

Key No.	Part No.	Q'ty	Description
2- 1	100 100-0393 0	1	Crankshaft ass'y
5	900 810-3620 1	2	Ball bearing
6	900 702-0003 2	2	Circlip
7	100 213-0393 0	2	Oilseal
8	100 131-0162 0	1	Key
9	900 611-0000 8	1	Lockwasher (TWB-8)
10	900 500-0000 8	1	Nut
11	100 012-0072 0	1	Roller bearing
12	100 015-0393 0	2	End ring
13	100 013-0393 0	1	Piston pin
14	100 010-1333 0	1	Piston
15	100 011-1333 0	2	Piston ring
21	175 005-1153 0	1	Clutch case
23	175 012-0393 0	1	Roller bearing
24	175 014-1153 0	1	Clutch washer
25	100 139-0393 0	1	Lock nut (6 φ L-h)
27	175 015-0393 0	1	Clutch washer (In.)
30	175 000-0393 1	1	Clutch ass'y
31	-175 019-1983 0	1	Side plate
32	-175 016-0393 1	1	Boss, clutch
33	-175 018-1983 0	1	Spring
34	-175 002-1983 0	1 set	Shoe
35	-900 281-0400 8	6	Screw

898 595-1333 1

3

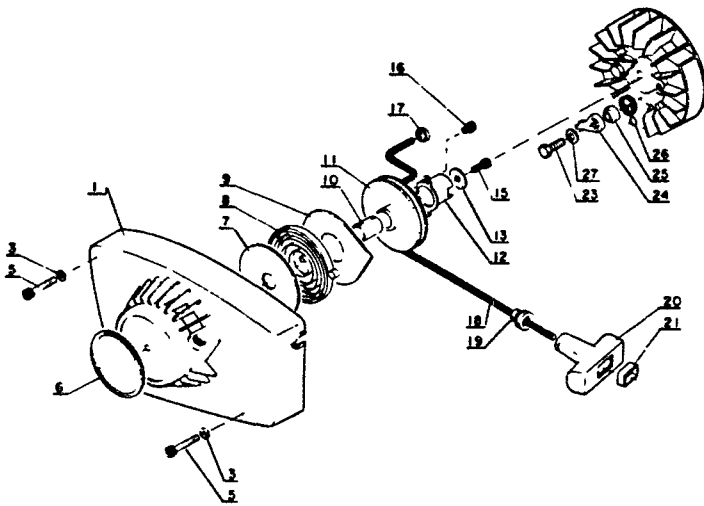

Key No.	Part No.	Q'ty	Description
3-	177 200-0393 0	1	Recoil starter ass'y
1	•101 507-0393 0	1	Fan cover
7	•177 221-0393 0	1	Side plate (A)
8	•177 220-0393 0	1	Spring rewind
9	•177 242-0393 0	1	Side plate (B)
10	•177 216-0393 0	1	Bushing
11	•177 215-0393 0	1	Recoil drum
12	•177 243-0393 0	1	Pawl catcher
13	•177 214-0393 0	1	Washer
15	•900 105-0401 2	1	Bolt 4x12
16	•900 241-0400 8	2	Screw
17	•177 246-0393 0	1	Rope clip
18	•177 226-0393 0	1	Starter rope
19	•177 227-0023 0	1	Rope guide
20	•177 228-1233 0	1	Recoil handle
21	•177 229-1433 0	1	End piece
3	900 600-0000 4	4	Washer
5	900 105-0403 0	4	Bolt 4x30
6	890 112-1783 1	1	Decal. ECHO
23	900 100-0501 6	2	Bolt
24	177 218-0393 0	2	Ratchet
25	177 247-0393 2	2	Spacer
26	177 234-0393 1	2	Ratchet spring
27	900 600-0000 5	2	Washer

4

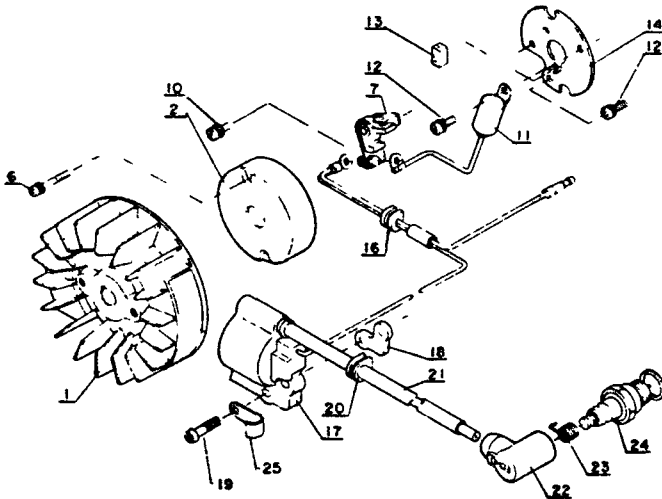

Key No.	Part No.	Q'ty	Description
4- 1	150 200-0393 1	1	Flywheel
2	156 112-0393 0	1	Breaker cover
6	900 242-0302 2	2	Screw
7	150 101-0393 0	1	Contact point set
10	900 242-0400 8	1	Screw
11	150 127-0393 0	2	Condenser
12	900 241-0401 2	1	Screw
13	150 134-0393 0	1	Oiler
14	150 132-0393 0	1	Stator plate
17	150 126-0393 0	1	Ignition coil
18	150 117-1373 0	2	Spacer, magneto
19	900 242-0402 0	1	Screw
20	150 110-0393 0	1	Rubber bush
21	150 111-0393 0	1	Tube, ignition cord
22	159 012-0343 3	1	Spark plug cap
23	159 011-0343 2	1	Spark plug connector
24	159 010-0033 0	1	Spark plug
25	159 113-0413 0	1	Clip

5

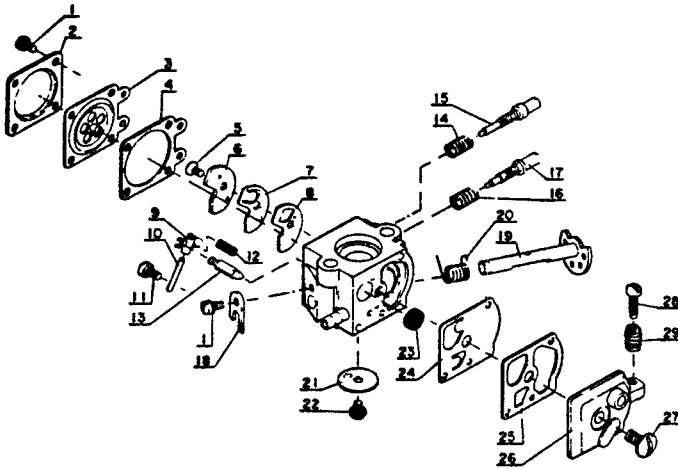

Key No.	Part No.	Q'ty	Description
5-	123 000-0393 1	1	Carburetor ass'y (WA-5B)
1	• 123 144-0393 0	5	Screw
2	• 123 142-0393 0	1	Metering diaphragm cover
3	• 123 141-0393 0	1	Metering diaphragm
4	• 123 140-0393 0	1	Metering diaphragm gasket
5	• 123 167-0523 0	1	Circuit plate Screw
6	• 123 166-0393 0	1	Circuit plate
7	• 123 165-0393 0	1	Check valve diaphragm
8	• 123 164-0393 0	1	Circuit plate
9	• 123 123-0393 0	1	Metering lever
10	• 123 138-0393 0	1	Metering lever pin
11	• 123 139-0393 0	1	Metering lever pin screw
12	• 123 122-1113 0	1	Metering lever Spring
13	• 123 137-0393 0	1	Inlet needle valve
14	• 123 119-0393 0	1	H.S. adjust spring
15	• 123 120-1003 0	1	High speed needle
16	• 123 121-0393 0	1	Idle needle adjust spring
17	• 123 118-0623 0	1	Idle needle
18	• 123 127-0393 0	1	Thrott'g shaft clip
19	• 123 117-0393 0	1	Thrott'g shaft
20	• 123 113-0393 0	1	Thrott'g turn f
21	• 123 116-0393 0	1	Thrott'g
22	• 123 114-0393 0	1	Shutter sc
23	• 123 126-0393 0	1	Inlet screen
24	• 123 112-0393 0	1	Pump diapl
25	• 123 125-0393 0	1	Pump gasket
26	• 123 124-0393 0	1	Pump cover
27	• 123 110-0393 0	1	Pump cover screw
28	• 123 134-0393 0	1	Idle adjust screw
29	• 123 133-0393 0	1	Idle adjust spring

6

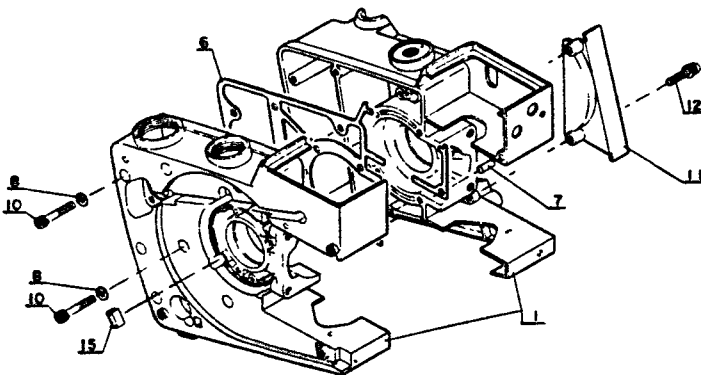

Key No.	Part No.	Q'ty	Description
6- 1	100 200-1333 0	1	Crankcase set
6	100 242-1333 0	1	Crankcase packing
7	100 215-0393 0	2	Knock pin
8	900 600-0000 4	14	Washer
10	900 105-0402 5	12	Bolt 4x25
11	100 618-0393 0	1	Dust seal plate
12	900 242-0402 0	2	Screw
15	100 614-0393 0	1	Plug

7

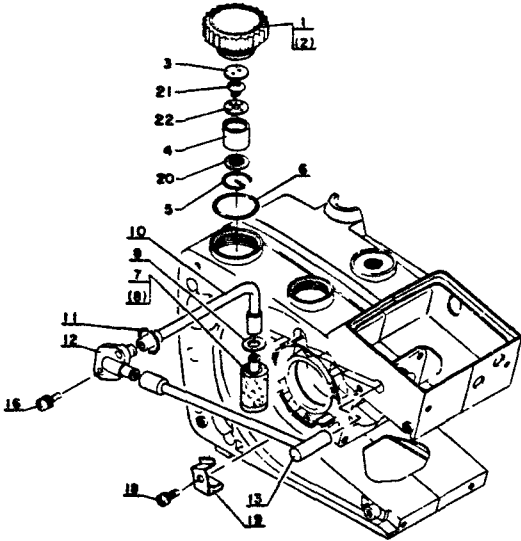

Key No.	Part No.	Q'ty	Description
7- 1	131 600-0393 2	1	Fuel tank cap ass'y
3	- 131 031-0343 0	1	Spacer,
4	- 131 030-0393 0	1	Supporter
5	- 131 032-0393 0	1	Circlip
20	- 131 035-0343 1	1	Filter
21	- 131 314-0033 0	1	Check valve
22	- 131 015-0343 0	1	Check valve holder
(2)	- 890 154-1513 0	1	Fuel label
6	- 900 720-0002 2	1	O-ring
7	131 200-0283 0	1	Fuel strainer
(8)	131 214-0283 0	1	Cap, strainer
9	900 603-0000 5	1	Washer 5
10	132 010-0393 0	1	Fuel pipe (Inner)
11	900 720-0001 4	1	O-ring (P-114)
12	132 011-0393 0	1	Fuel pipe connector
13	132 012-0393 0	1	Fuel pipe (Outer)
16	900 242-0401 2	2	Screw
18	900 242-0401 0	1	Screw
19	159 112-0393 0	1	Clip

8

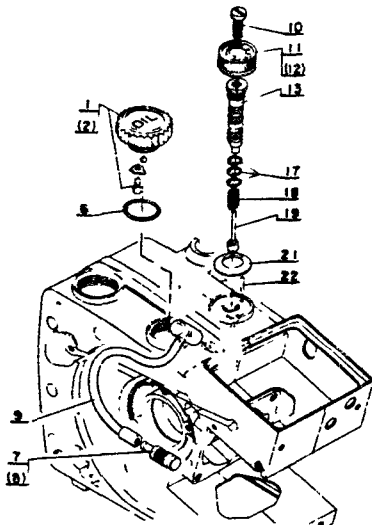

Key No.	Part No.	Q'ty	Description
8- 1	436 002-1143 0	1	Cap ass'y
(2)	- 890 153-1143 0	1	Oil label
6	- 900 720-0001 6	1	O-ring (P-116)
7	436 205-0283 2	1	Oil strainer
9	437 211-0393 1	1	Oil pipe (inner)
10	900 220-0501 4	1	Screw
11	437 039-0343 0	1	Dial
(12)	890 022-0343 0	1	Caution label
13,19	437 000-0343 0	1	Auto, oiler ass'y
17	- 437 020-0283 0	3	O-ring (S-5)
18	- 437 019-0283 0	1	Spring
21	437 036-0343 0	1	Flat spring
22	900 330-1509 8	1	Needle roller

9

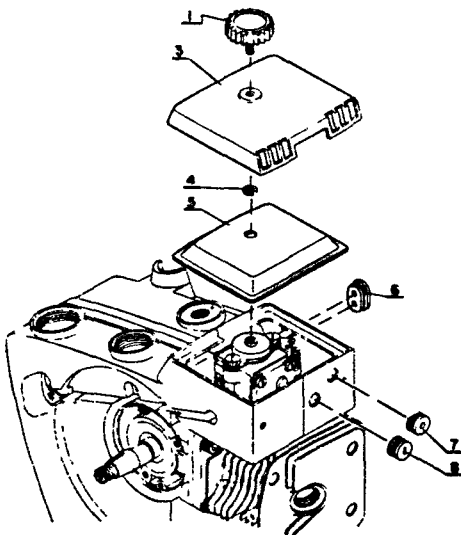

Key No.	Part No.	Q'ty	Description
9- 1	130 406-03930	1	Thumb bolt
3	130 313-03930	1	Air cleaner cover
4	900 700-00002	1	E-ring
5	130 310-0393 0	1	Air cleaner
6	129 010-0393 0	1	Grommet
7	178 810-0393 0	1	Rubber bush
8	178 210-0023 0	1	Rubber bush

10

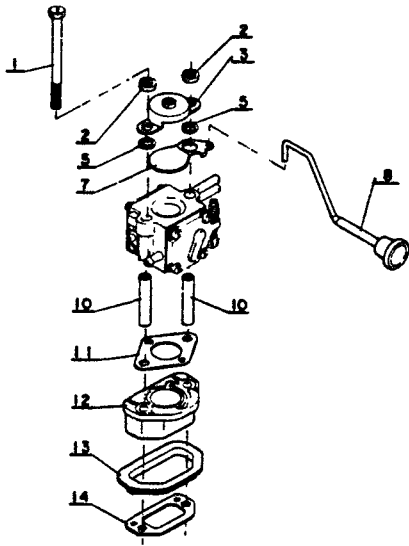

Key No.	Part No.	Q'ty	Description
10- 1	130 021-0393 0	2	Bolt,
2	130 029-0393 0	2	Washer, carb.
3	130 405-0393 0	1	Cleaner set plate
5	178 516-0393 0	2	Washer
7	178 515-0393 0	1	Choke shutter
8	178 510-0393 2	1	Choke rod
10	130 019-0393 0	2	Spacer
11	130 016-0393 1	1	Packing (B)
12	130 017-0393 1	1	Insulator
13	130 012-0393 0	1	Dust seal, carb.
14	130 010-0393 1	1	Packing (A)

11

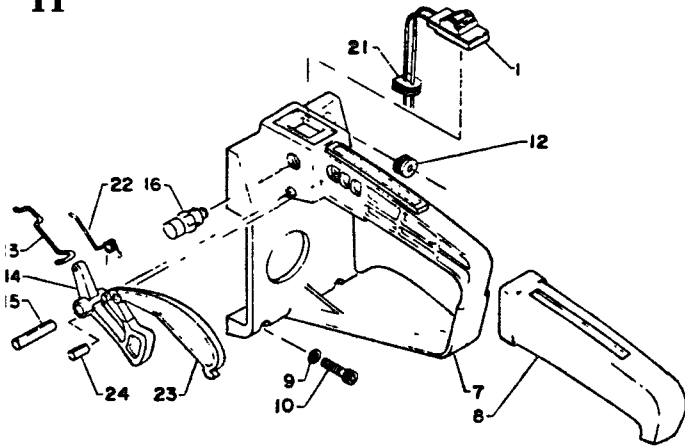

Key No.	Part No.	Q'ty	Description
11- 1	163 400-1333 0	1	Stop switch ass'y
7	351 110-1333 0	1	Right handle
8	351 111-1333 0	1	Right handle rubber
9	900 600-0000 4	4	Washer
10	900 105-0401 8	4	Bolt 4x18
12	178 810-0393 0	1	Rubber bush
13	178 011-1333 0	1	Throttle connectin
14	178 010-1333 0	1	Throttle trigger
15	900 340-5002 5	1	Spring pin
16	178 302-1233 0	1	Throttle latch ass'y
21	156 114-0231 0	1	Grommet
22	178 091-1333 0	1	Spring, T.C.L
23	178 090-1333 0	1	Throttle control lockout
24	900 340-4001 0	1	Spring pin 4x10

12

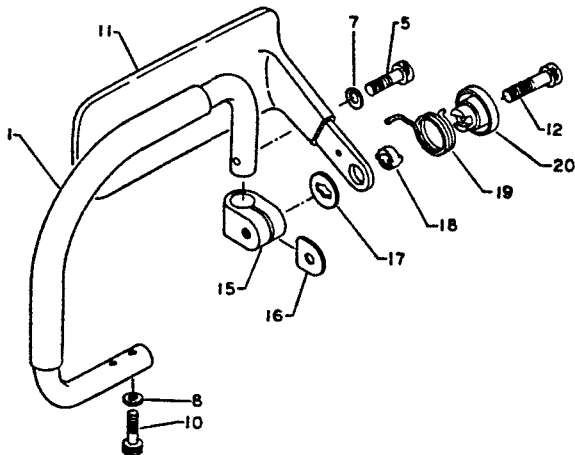

Key No.	Part No.	Q'ty	Description
12- 1	351 205-1333 0	1	Front handle
5	900 105-0502 0	1	H.S.H.bolt 5x20
7	100 247-0283 0	1	Washer
8	900 600-0000 4	2	Washer 4
10	900 105-0401 8	2	H.S.H.bolt 4x18
	351 800-1333 2	1	Hand guard ass'y
11	-351 805-1333 1	1	Hand guard
12	-900 162-0503 0	1	H.S.H.bolt 5x30
15	-351 835-1333 0	1	Holder
16	-351 841-1333 0	1	Spacer
17	-351 828-1333 0	1	Wasker
18	-351 827-1333 1	1	Spacer
19	-351 836-1333 0	1	Spring, guard
20	-351 833-1333 0	1	Retainer

### 13

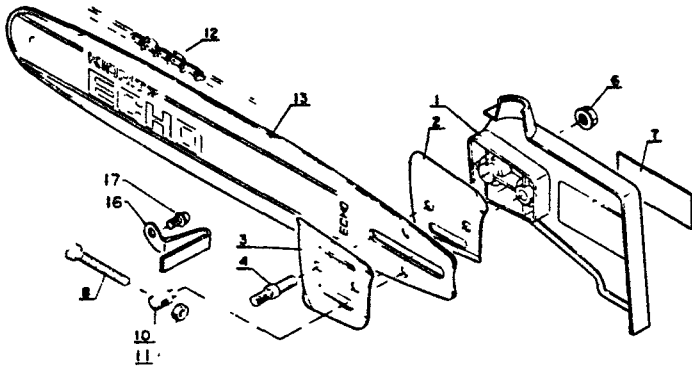

Key No.	Part No.	Q'ty	Description
13-1	433 021-1143 0	1	Guide bar cover
2	433 012-0393 0	1	Side plate (outer)
3	433 013-0393 0	1	Side plate (inner)
4	433 011-0393 0	2	Stud bolt
6	433 019-0393 3	2	Flange nut
7	890 118-1833 1	1	"ECHO" name plate
8	433 016-0283 0	1	Adjusting screw
10	433 014-0393 2	1	Tensioner
11	433 022-0283 0	1	Lock nut
16	433 026-0393 0	1	Chain catcher
17	900 242-0501 0	1	Screw 5×10

### 14 (Special items to order)

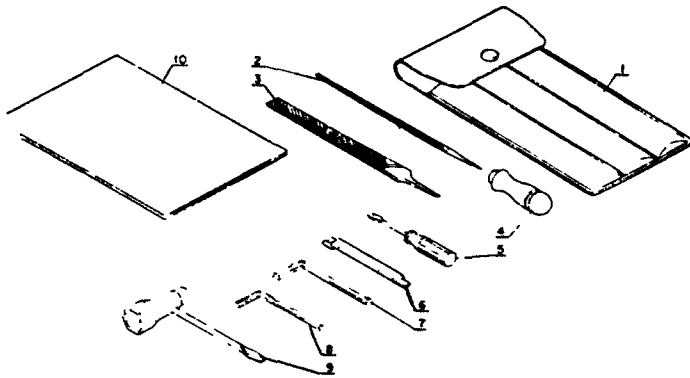

Key No.	Part No.	Q'ty	Description
14-	896 000-0393 0	1	Tool set
1	• 898 510-0111 1	1	Tool bag
2	• 897 510-0393 0	1	Round file
3	• 897 511-0023 0	1	Flat file
4	• 897 512-0023 0	1	File grip
5	• 895 812-0393 0	1	Screw-driver (50 mm)
6	• 897 514-0083 1	1	Depth gauge
7	• 895 610-0013 0	1	L-wrench (4 mm)
8	• 895 612-0343 0	1	L-wrench (3 mm)
9	• 895 410-0393 0	1	Box wrench, W/driver
10		1	Operator manual