



OPTIONAL ATTACHMENTS & ACCESSORIES**Accessories**

103942147	CS Carry Bag
103942148	CS Camouflage Carry Bag
89850308034	Bar & Chain Cover
99988801207	ToughChest Chain Saw Case

Guide Bars

12A0CD3745	Guide Bar - 12" (.050" Ga)
16A0CD3757	Guide Bar - 16" (.050" Ga)

Sawing Chains

91VG45CQ	Sawing Chain - 12" (.050" Ga)
91VG57CQ	Sawing Chain - 16" (.050" Ga)

PARTS CATALOG
CS-310 Chain Saw**30.5cc**

SERIAL NUMBERS

S/N: C04612001001 - C04612999999

ECHO, INCORPORATED

400 Oakwood Road Lake Zurich, Illinois 60047 USA

WWW.ECHO-USA.COM



Table of Contents

Click Any Diagram Description Below To View That Diagram.

CS-310 S/N: C04612001001 - C04612999999

Cylinder Cover, Intake, Fuel System.....	4
Carburetor -- WT-946.....	6
Exhaust.....	8
Chain Brake.....	10
Standard Guide Bar, Sawing Chain, Kick Guard.....	12
Starter.....	14
Clutch.....	16
Ignition.....	18
Handles, Throttle Control.....	20
Auto-Oiler.....	22
Engine, Engine Housing.....	24
Labels.....	26
Tools.....	28
Part Number Index.....	30
Part Description Index.....	31

This Page Intentionally Left Blank

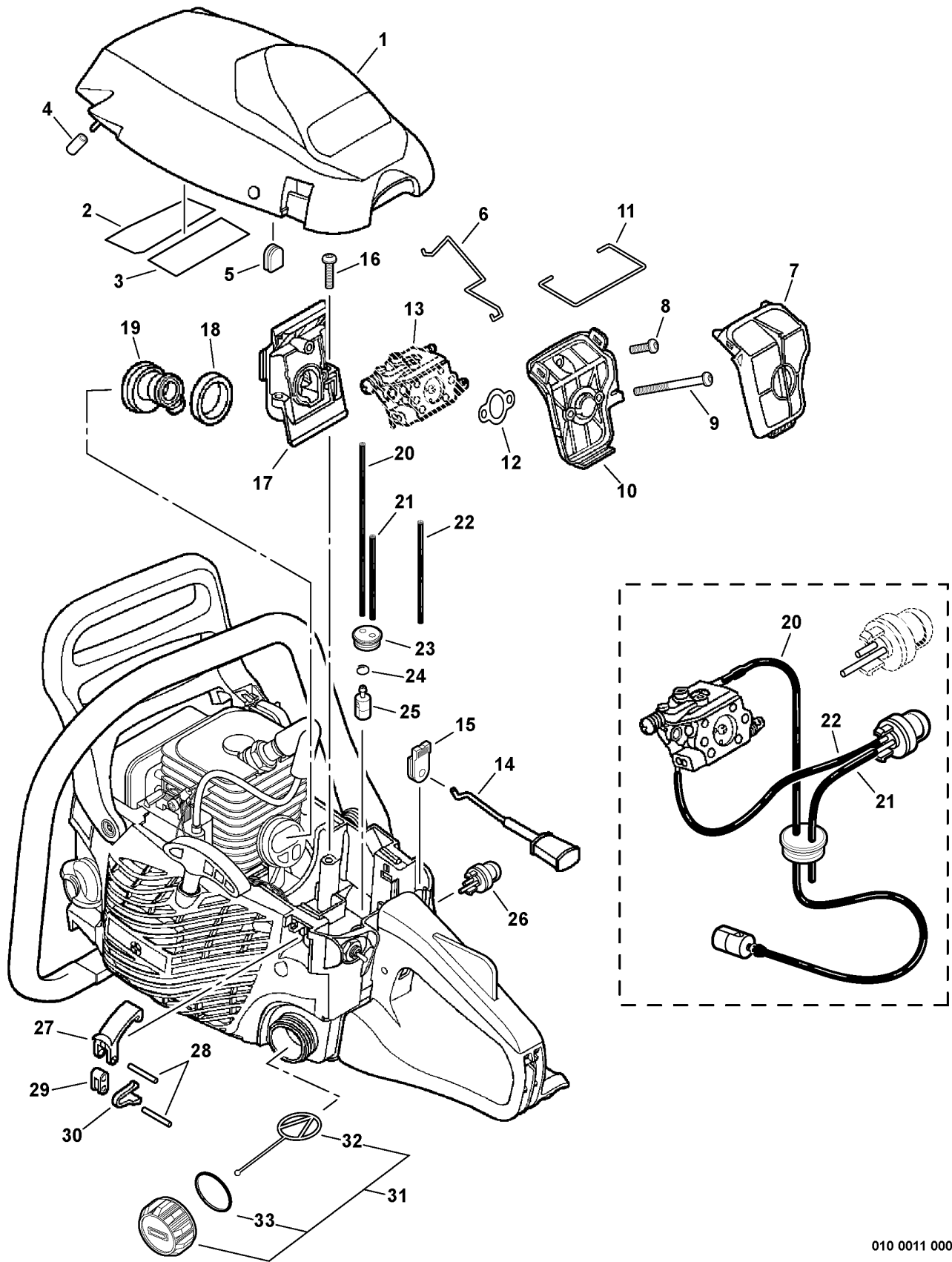

010 0011 000

ITEM	PART NUMBER	QTY	DESCRIPTION	REMARKS
1	A160001070	1	COVER, ENGINE	
2	V341000120	1	DEFLECTOR, HEAT	
3	V341000110	1	DEFLECTOR, HEAT	
4	10092735830	1	BUSHING	
5	13033832430	1	PLUG	
6	C454000160	1	ROD, THROTTLE	
7	A226000420	1	FILTER, AIR	
8	V805000000	1	SCREW 5X16 - TAPPING	
9	V805000040	2	SCREW 5X55	
10	A225000280	1	BRACKET, AIR CLEANER	
11	V582000050	1	RETAINER, AIR FILTER	
12	V103000500	1	GASKET, INTAKE	
13	-----	1	CARBURETOR	See Carburetor Diagram For Additional Information
14	A241000150	1	ROD, CHOKE	
15	V130000010	1	GROMMET	
16	V805000010	2	SCREW 5X20 - TAPPING	
17	A200000350	1	INSULATOR, INTAKE	
18	A206000000	1	RETAINER, BELLOWS	
19	A202000070	1	BELLOWS	
20	V471002170	1	PIPE, FUEL - 3X5X230mm	REPOWER BULK OPTION: 90014
21	V471001560	1	PIPE, RETURN - 3X5X80mm	REPOWER BULK OPTION: 90014
22	V471002190	1	PIPE, PURGE - 3X5X125mm	REPOWER BULK OPTION: 90014
23	13211544330	1	GROMMET	
24	13201309820	1	CLIP	
25	13120507320	1	FILTER, FUEL	
26	12318139130	1	PUMP, PURGE	
27	C463000030	1	LATCH, ENGINE COVER	
28	9305040180	1	PIN	
29	J485000200	1	HINGE	
30	V490000400	1	RETAINER	
31	13100437932	1	CAP ASY - ORANGE	INCLUDES ITEMS 32-33
32	A365000050	1	CONNECTOR, CAP	
33	90072000022	1	O-RING 22	

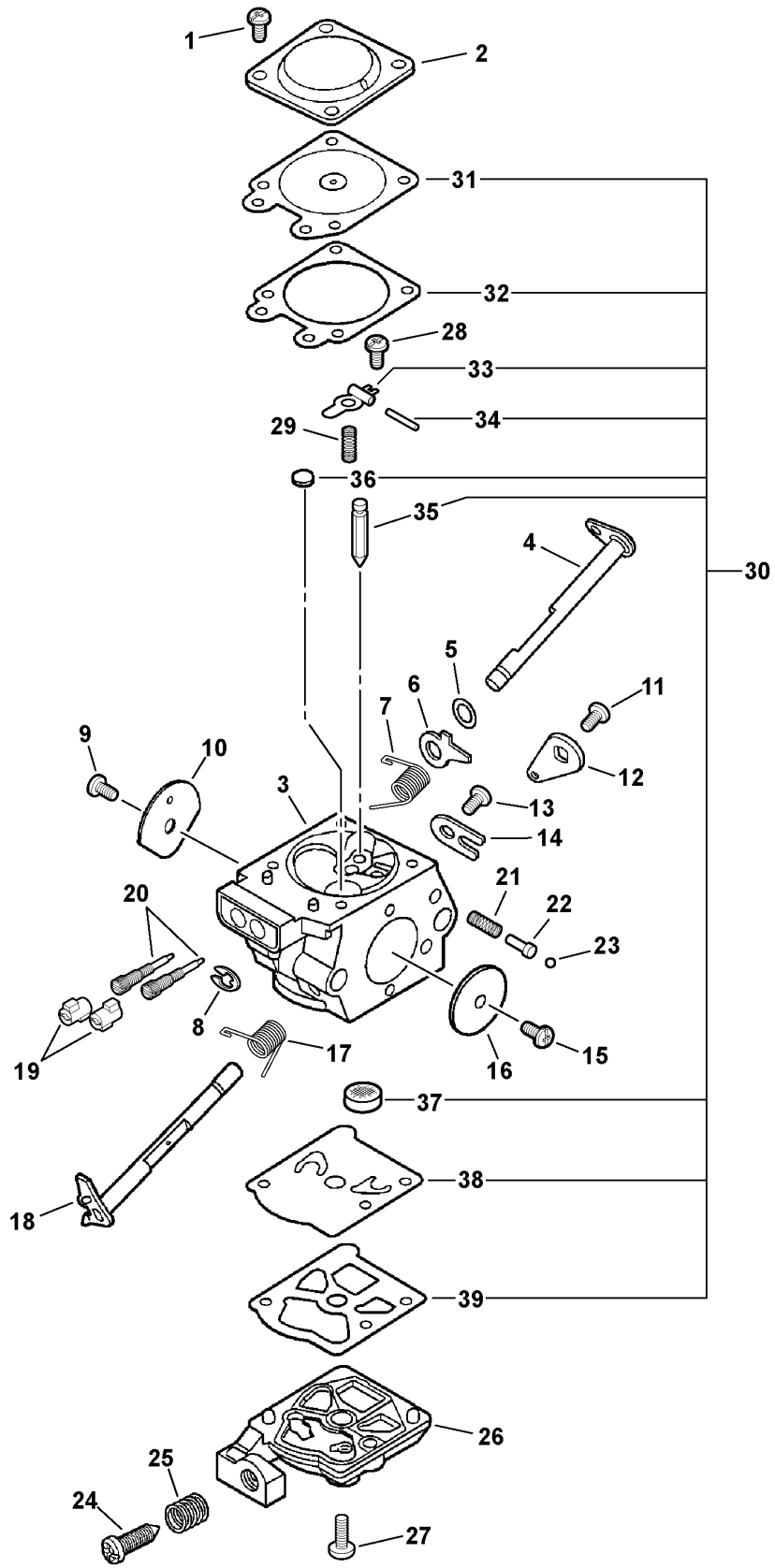

WT946 0000 000

ITEM	PART NUMBER	QTY	DESCRIPTION	REMARKS
	A021001700	1	CARBURETOR -- WT-946	
1	12313002960	4	SCREW, DIAPHRAGM COVER	
2	12314203930	1	COVER, METERING DIAPHRAGM	
3	-----	1	BODY, CARBURETOR ¹	
4	P003000150	1	SHAFT, CHOKE	
5	12314926030	1	WASHER	
6	P003001510	1	LEVER, FAST IDLE	
7	P003002260	1	SPRING	
8	12312715030	1	CIRCLIP	
9	12311403930	1	SCREW, CHOKE VALVE	
10	P003002250	1	VALVE, CHOKE	
11	12311403930	1	SCREW, THROTTLE LEVER	
12	P003001040	1	LEVER, THROTTLE	
13	12313002960	1	SCREW, CLIP	
14	12312703930	1	CLIP, THROTTLE SHAFT	
15	12311403930	1	SCREW, THROTTLE VALVE	
16	12311605960	1	VALVE, THROTTLE	
17	12311337530	1	SPRING, THROTTLE RETURN	
18	P003002240	1	SHAFT, THROTTLE	
19	P003000010	2	CAP, MIXTURE LIMITER	
20	12311802261	2	NEEDLE, MIXTURE ADJUSTMENT	
21	12318609660	1	SPRING	
22	12318509660	1	PISTON ASY	
23	12313609660	1	BALL	
24	12313404260	1	SCREW, IDLE ADJUST	
25	12313304260	1	SPRING, IDLE ADJUST	
26	12312409520	1	COVER, FUEL PUMP	
27	12311003930	1	SCREW, PUMP COVER	
28	12313903930	1	SCREW, METERING LEVER PIN	
29	12312239330	1	SPRING, METERING LEVER	
30	P003002190	1	REPAIR KIT	INCLUDES ITEM 31-39
31	-----	1	DIAPHRAGM, METERING	
32	-----	1	GASKET, METERING DIAPHRAGM	
33	-----	1	LEVER, METERING	
34	-----	1	PIN, METERING LEVER	
35	-----	1	VALVE, INLET NEEDLE	
36	-----	1	PLUG, WELCH	
37	-----	1	SCREEN, INLET	
38	-----	1	DIAPHRAGM, FUEL PUMP	
39	-----	1	GASKET, FUEL PUMP	

Footnotes

1: NOT AVAILABLE SEPARATELY

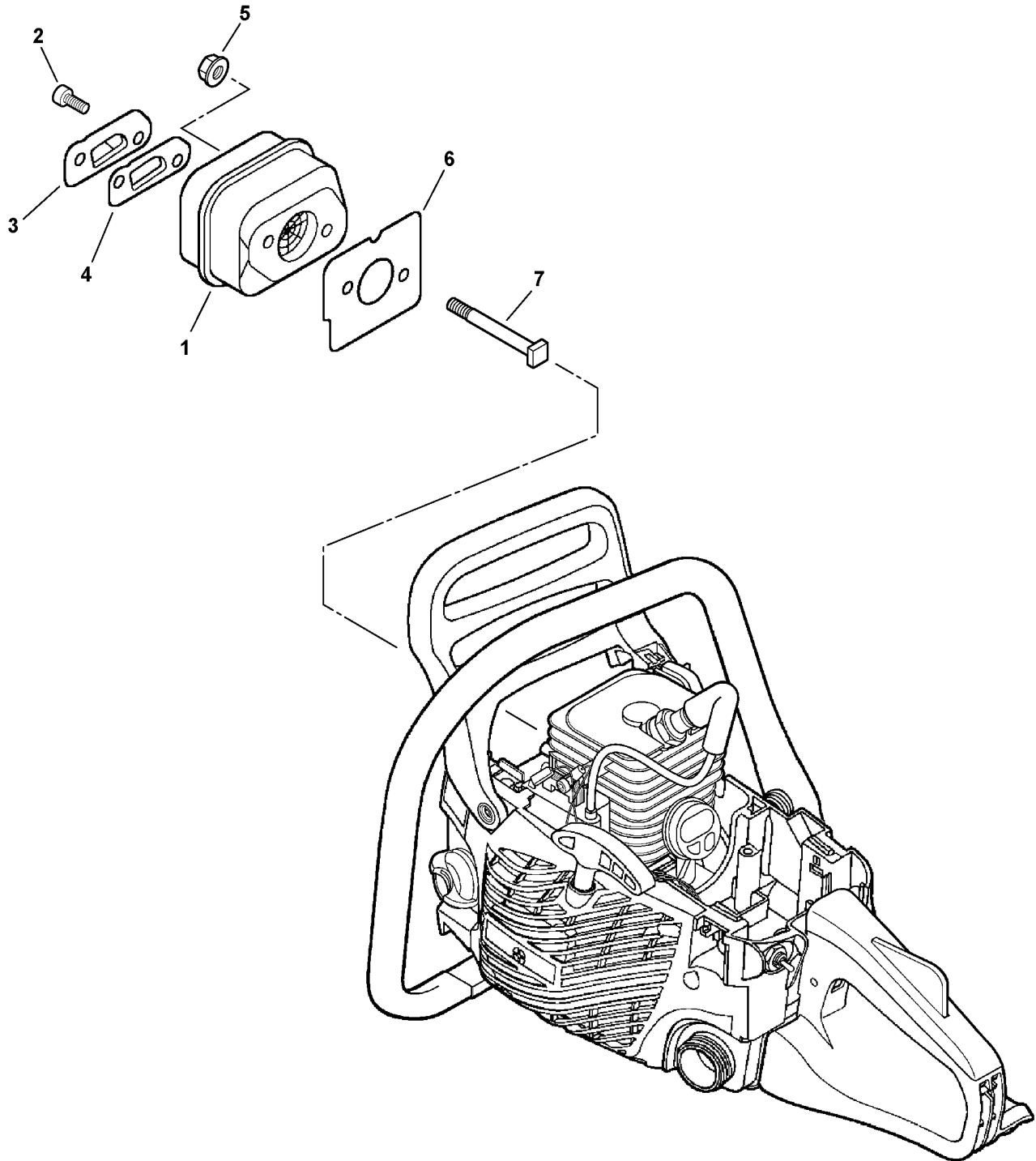

011 0003 000

CS-310 Chain Saw

Exhaust

ITEM	PART NUMBER	QTY	DESCRIPTION	REMARKS
1	A300000620	1	MUFFLER	
2	V804000030	2	SCREW 4X8	
3	A313000760	1	GUIDE, EXHAUST	
4	A310000060	1	SCREEN	
5	90051600005	2	FLANGE NUT 5	
6	V104000731	1	GASKET, EXHAUST	
7	V203000120	2	BOLT	

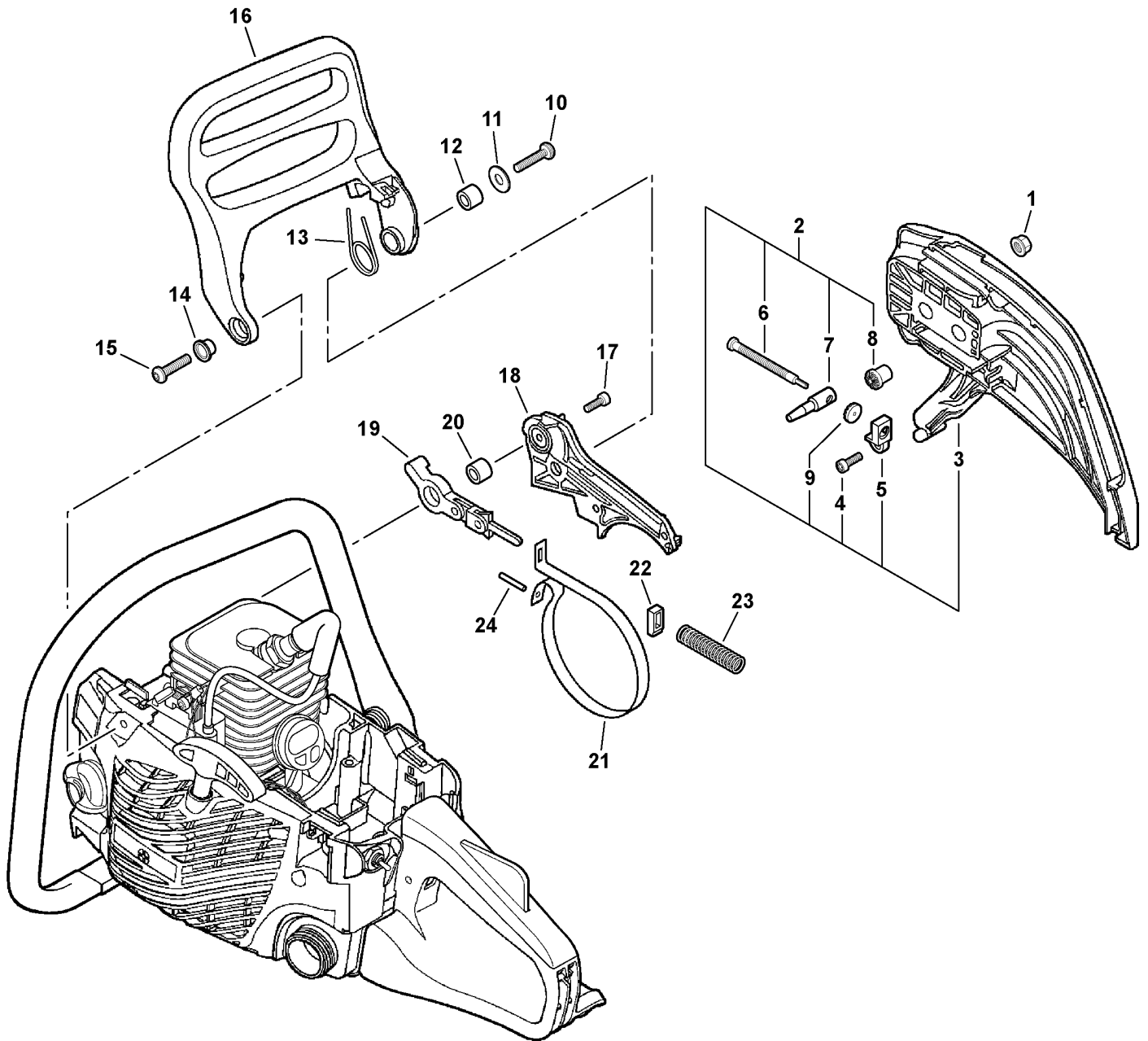

013 0012 000

ITEM	PART NUMBER	QTY	DESCRIPTION	REMARKS
1	43301912330	2	FLANGE NUT	
2	P021015110	1	GUIDE BAR COVER ASY	INCLUDES ITEMS 3-9
3	C300000400	1	GUARD, SPROCKET	
4	V804000000	1	SCREW 4X12 - TAPPING	
5	V355000140	1	COLLAR	
6	V203000110	1	DRIVE, TENSIONER	
7	C309000030	1	TENSIONER, CHAIN	
8	V651000001	1	GEAR, BEVEL	
9	V651000011	1	GEAR, BEVEL	
10	V804000020	1	SCREW 4X20 - TAPPING	
11	17721403930	1	WASHER	
12	43311635430	1	SPACER 8X12X9	
13	V452000250	1	SPRING	
14	V356000430	1	SPACER	
15	V805000010	1	SCREW 5X20 - TAPPING	
16	C320000170	1	LEVER, BRAKE	
17	V804000000	3	SCREW 4X12 - TAPPING	
18	C345000270	1	COVER, BRAKE	
19	C334000100	1	CONNECTOR, BRAKE	
20	43311635430	1	SPACER 8X12X9	
21	C328000030	1	BAND, BRAKE	
22	V376000450	1	SPACER	
23	V450000070	1	SPRING	
24	9305030098	1	PIN	

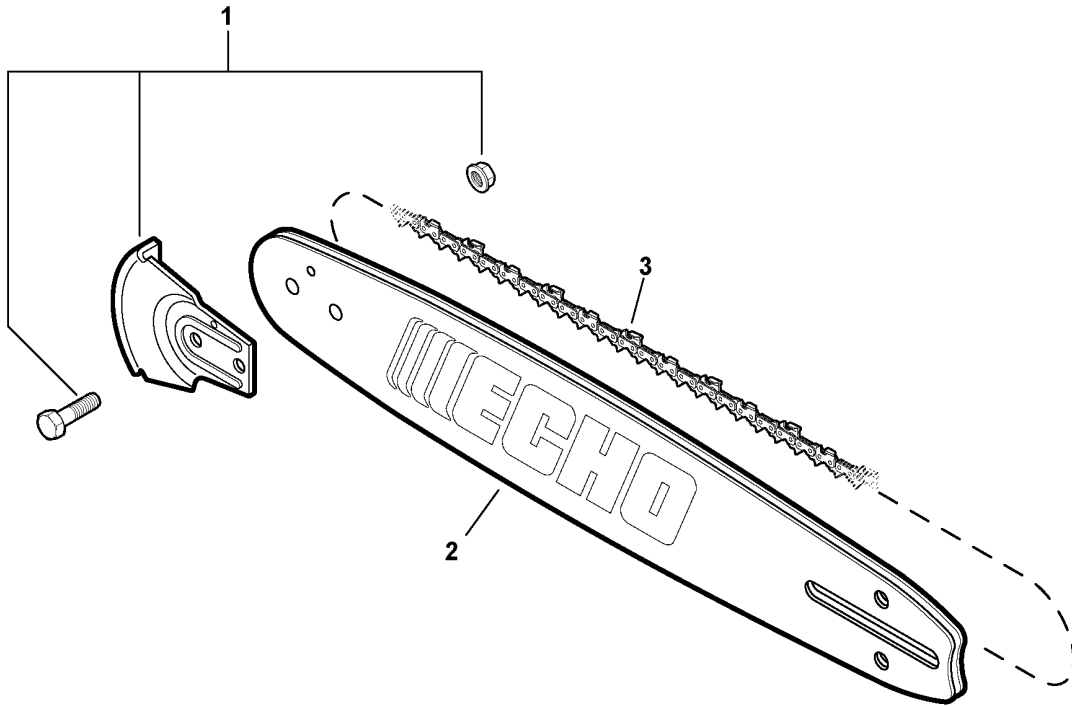

016 0011 000

ITEM	PART NUMBER	QTY	DESCRIPTION	REMARKS
1	2894901	1	KICK GUARD KIT	
2	14A0CD3752	1	GUIDE BAR - 14" -- Double-Guard 91	GAUGE: .050"
3	91VG52CQ	1	SAWING CHAIN - 14" -- XtraGUARD ¹	GAUGE: .050" / PITCH: .375"

Footnotes

¹: Low Vibration

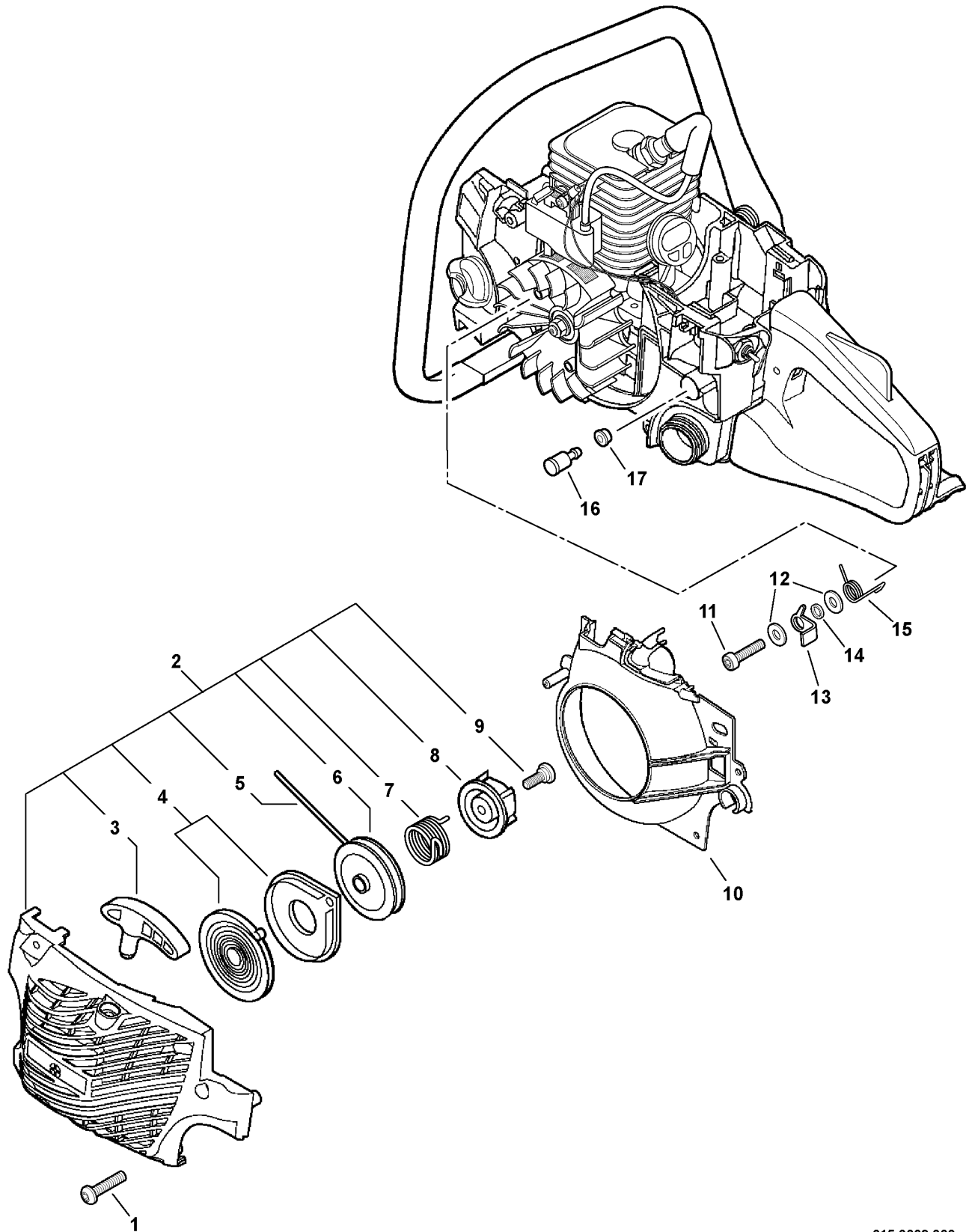

015 0009 000

ITEM	PART NUMBER	QTY	DESCRIPTION	REMARKS
1	V805000010	4	SCREW 5X20 - TAPPING	
2	A051001300	1	STARTER ASY	INCLUDES ITEMS 3-9
3	P022005891	1	GRIP, STARTER	
4	P022001330	1	REWIND SPRING KIT	
5	P022008440	1	ROPE, STARTER - 3.5X900mm	REPOWER BULK OPTION: 99944445000
6	A506000030	1	REEL, ROPE	
7	V452000220	1	SPRING	
8	P022022000	1	CATCHER, PAWL	
9	17723661830	1	SCREW	
10	A172000830	1	COVER, FAN	
11	V203000080	2	SCREW 5	
12	90060300005	4	WASHER 5	
13	A514000020	2	PAWL	
14	17724704630	2	SPACER	
15	17723435430	2	SPRING, RETURN	
16	A356000030	1	VENT ASY	
17	V137000000	1	GROMMET	

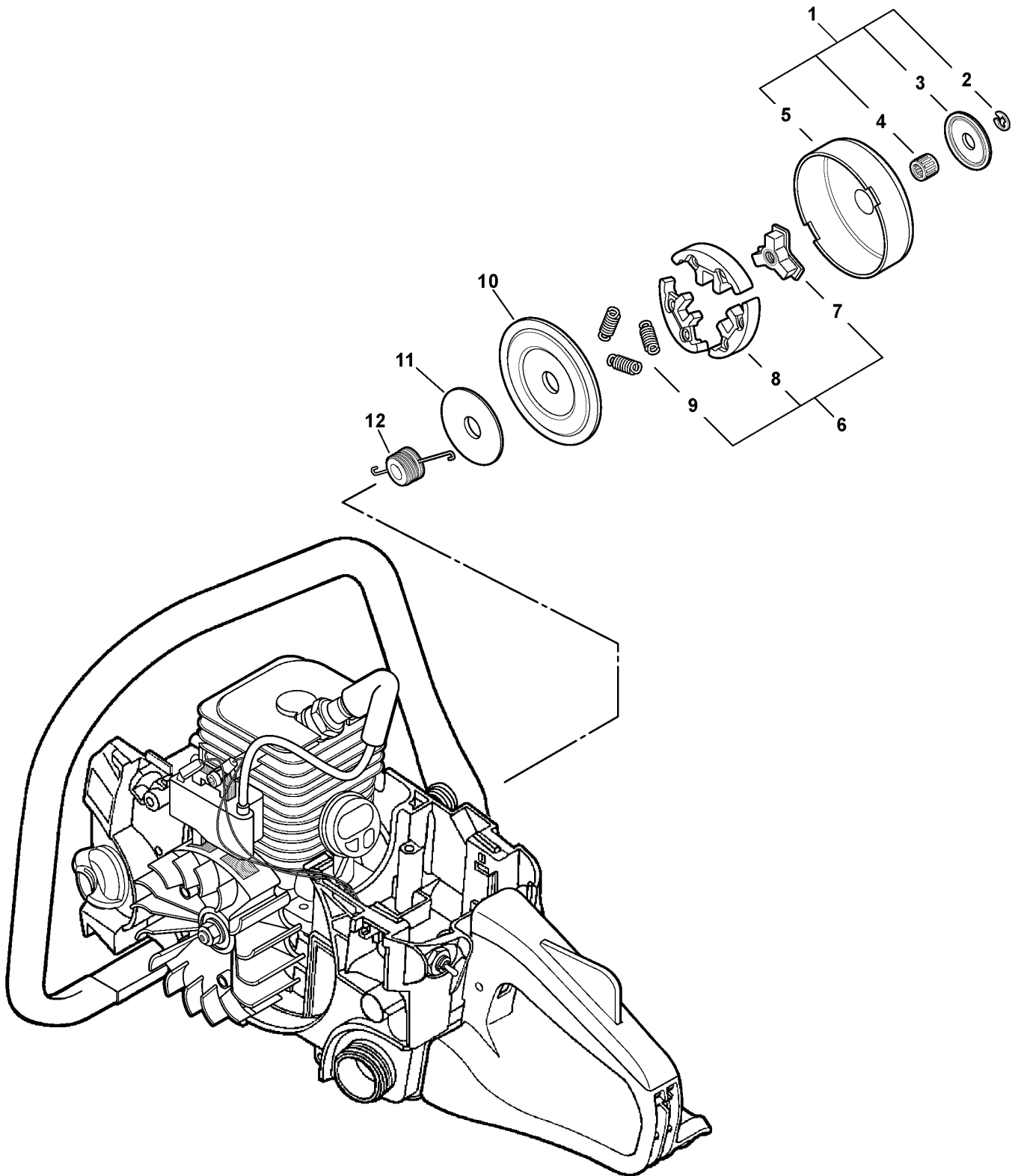

014 0009 000

ITEM	PART NUMBER	QTY	DESCRIPTION	REMARKS
1	99944400395	1	CLUTCH KIT	
2	V583000120	1	E RING	
3	10014319830	1	WASHER	
4	17501203930	1	BEARING, NEEDLE	
5	A556000540	1	DRUM, CLUTCH	
6	A056000210	1	CLUTCH ASY	INCLUDES ITEM 7-9
7	A552000100	1	HUB, CLUTCH	
8	P021005810	1	CLUTCH SHOE SET	CONTAINS 3 PIECES
9	V451000470	3	SPRING, CLUTCH	
10	A551000090	1	PLATE, CLUTCH	
11	A551000080	1	PLATE, CLUTCH	
12	V652000040	1	GEAR, WORM	

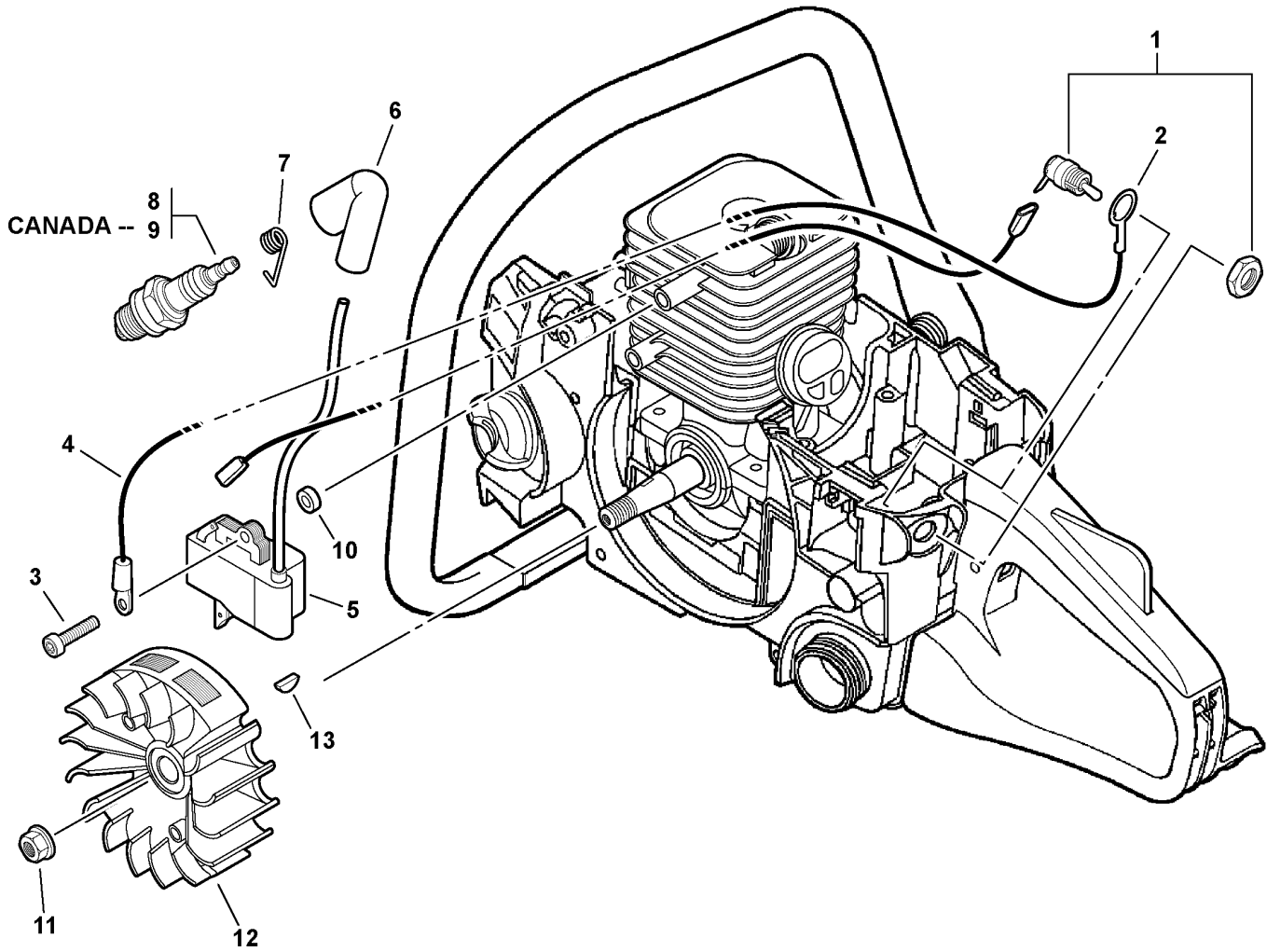

018 0010 000

ITEM	PART NUMBER	QTY	DESCRIPTION	REMARKS
1	A440001190	1	SWITCH, IGNITION	
2	V485001070	1	LEAD, GROUND	
3	V805000210	2	SCREW 5X20	
4	V485001080	1	LEAD, IGNITION	
5	A411000460	1	COIL, IGNITION	
6	A427000020	1	CAP, SPARK PLUG	
7	A426000020	1	TERMINAL, SPARK PLUG CAP	
8	15901019830	1	SPARK PLUG -- BPM-8Y	
9	A425000000	1	SPARK PLUG -- BPMR-8Y	CANADA MODELS
10	15011716430	2	SPACER	
11	90051500008	1	FLANGE NUT 8	
12	A409000350	1	FLYWHEEL	
13	10014212330	1	WOODRUFF KEY	

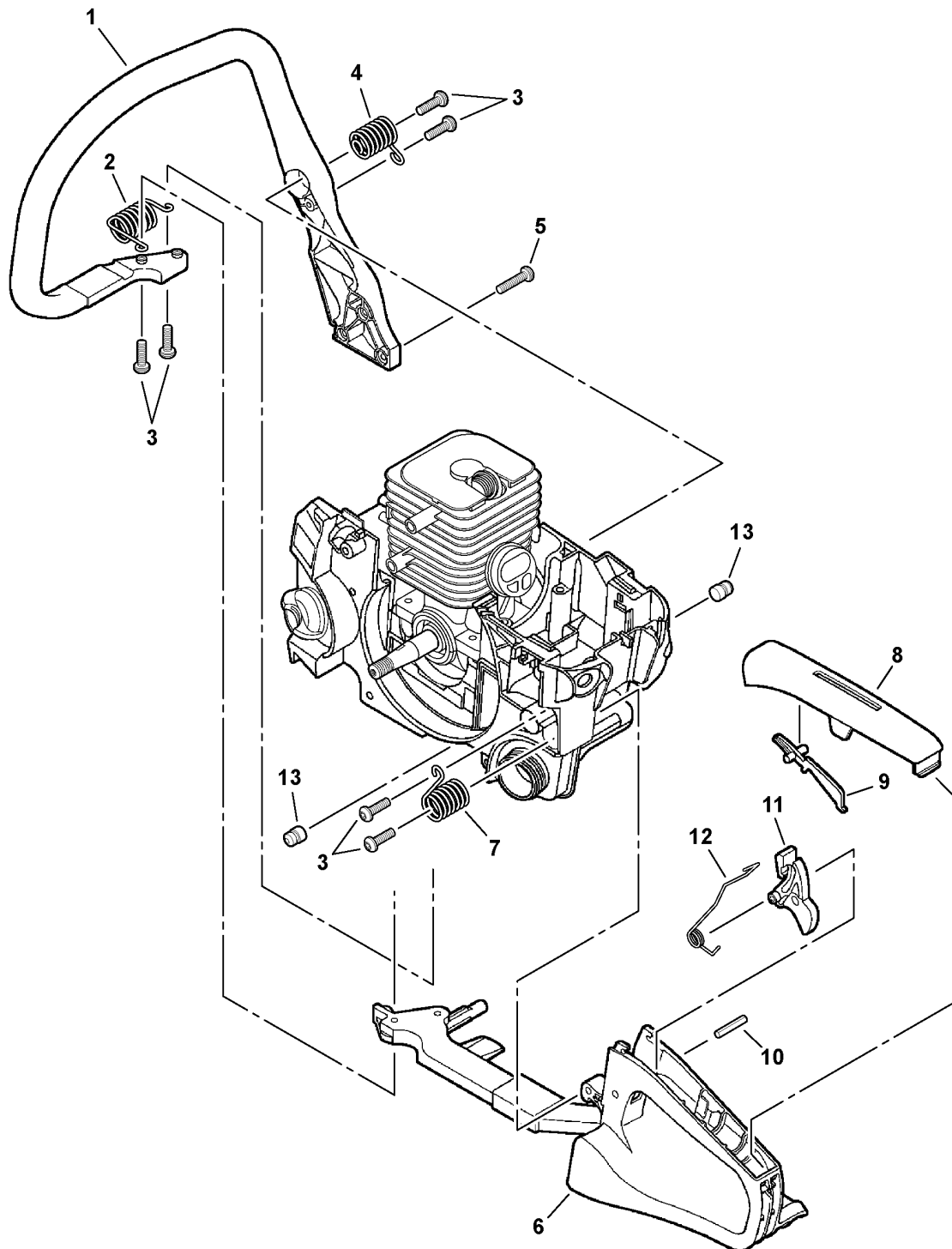

012 0010 000

ITEM	PART NUMBER	QTY	DESCRIPTION	REMARKS
1	C400000541	1	HANDLE, FRONT	
2	V450000710	1	SPRING	
3	V805000000	7	SCREW 5X16 - TAPPING	
4	V450000700	1	SPRING	
5	V805000010	3	SCREW 5X20 - TAPPING	
6	C410000450	1	HANDLE, REAR	
7	V450000720	1	SPRING	
8	C411000040	1	COVER, HANDLE	
9	C460000072	1	LOCKOUT, THROTTLE	
10	90034540025	1	SPRING PIN 4X25	
11	C450000212	1	TRIGGER, THROTTLE	
12	V452000260	1	SPRING, TRIGGER RETURN	
13	V420001790	2	CUSHION	

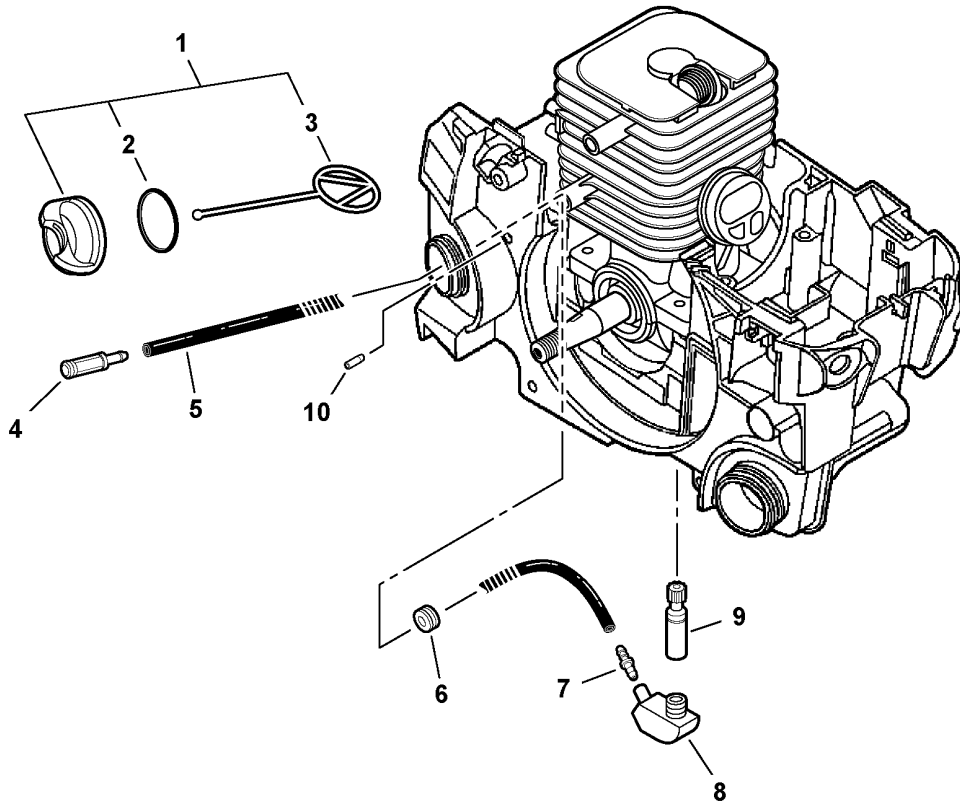

017 0008 000

ITEM	PART NUMBER	QTY	DESCRIPTION	REMARKS
1	P021005581	1	CAP ASY - BLACK	INCLUDES ITEMS 2-3
2	90072000018	1	O-RING	
3	A365000050	1	CONNECTOR, CAP	
4	43620502832	1	FILTER, OIL	
5	13011005260	1	PIPE, OIL	
6	13211501461	1	GROMMET	
7	V186000020	1	CONNECTOR	
8	V470000810	1	GROMMET, OIL	
9	C022000040	1	AUTO-OILER ASY	
10	43611413930	1	VALVE, CHECK	

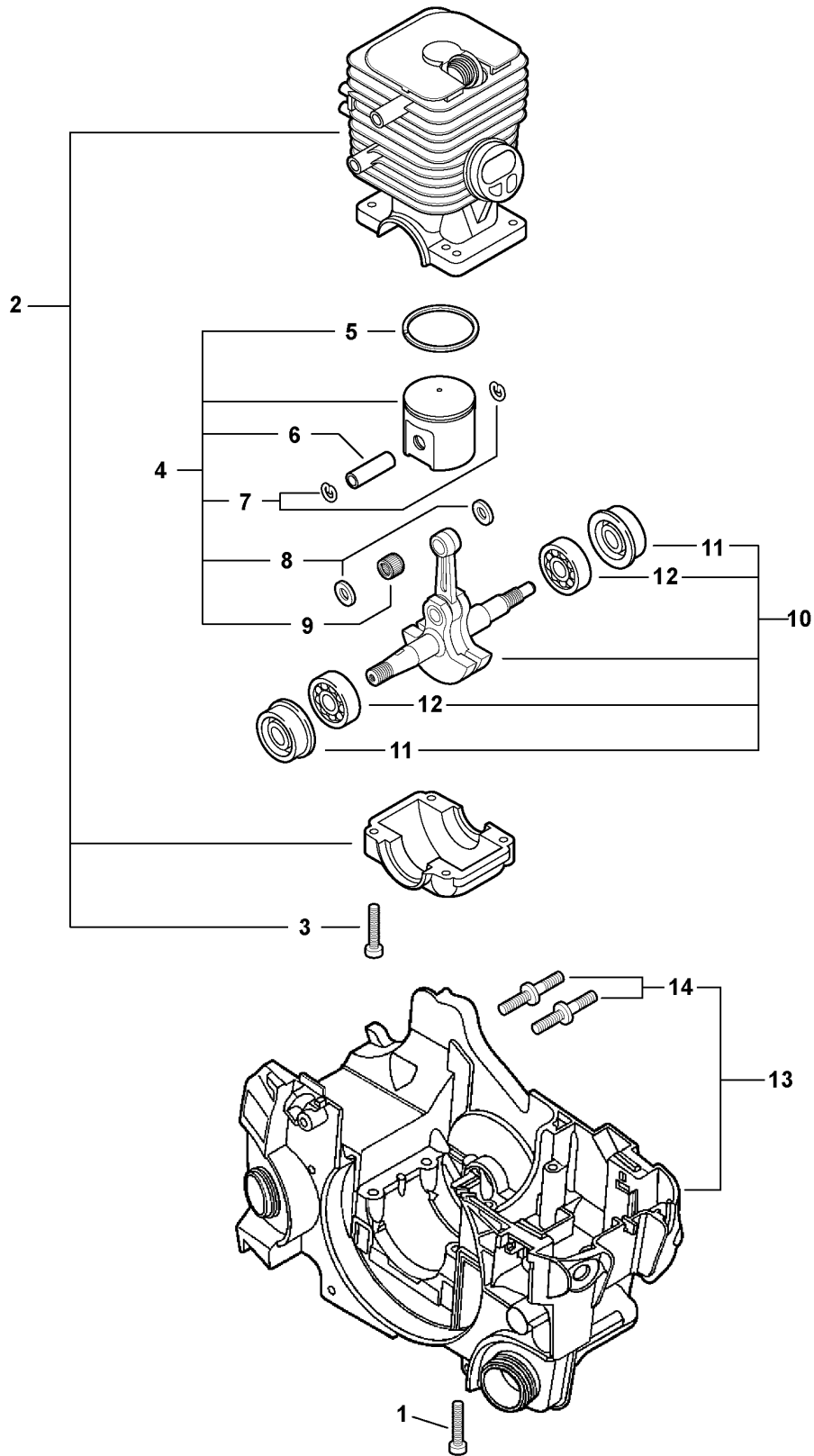

SB10XX 0009 000

ITEM	PART NUMBER	QTY	DESCRIPTION	REMARKS
1	V805000180	4	SCREW 5X30	
2	P021015050	1	CRANKCASE SET	INCLUDES ITEM 3
3	V805000220	4	SCREW 5X25	
4	P021015060	1	PISTON KIT	INCLUDES ITEMS 5-9
5	10001116131	1	RING, PISTON	
6	10001315330	1	PIN, PISTON	
7	10001504630	2	CIRCLIP, PISTON PIN	
8	10001411520	2	SPACER, PISTON PIN	
9	10011311520	1	BEARING, NEEDLE	
10	P021015070	1	CRANKSHAFT ASY	INCLUDES ITEMS 11-12
11	V505000010	2	OIL SEAL	
12	9403536201	2	BEARING, BALL - 6202	
13	P021015080	1	ENGINE HOUSING ASY	INCLUDES ITEM 14
14	V225000030	2	STUD, GUIDE BAR	

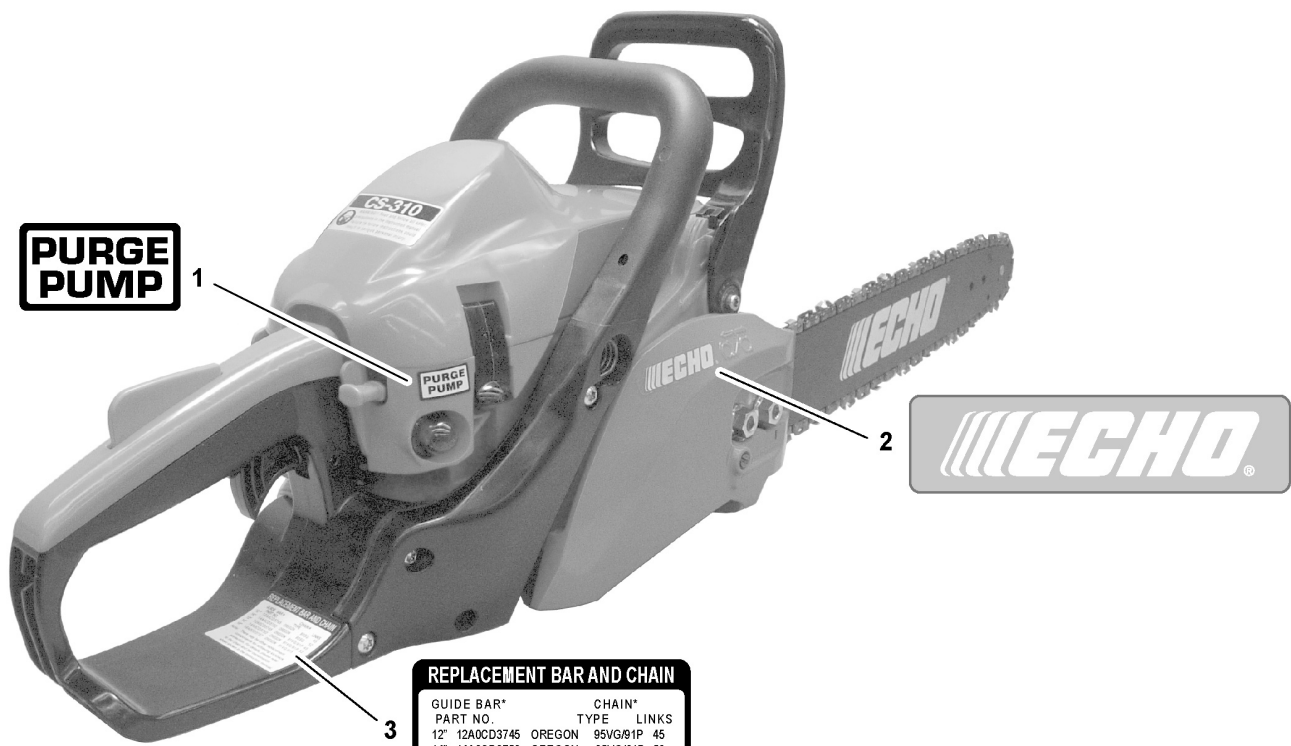

PURGE PUMP



REPLACEMENT BAR AND CHAIN

GUIDE BAR*	CHAIN*
PART NO.	TYPE LINKS
12" 12A0CD3745	OREGON 95VG/91P 45
14" 14A0CD3752	OREGON 95VG/91P 52
16" 16A0CD3757	OREGON 95VG/91P 57

*Or equivalent

Note: There may be other replacement components for achieving kickback protection. For details, please refer to the bar and chain combination sheet shown in the instruction manual

TO AVOID KICKBACK

1. Hold the chain saw firmly with both hands
2. Don't let the nose of the guide bar contact any obstruction.
3. Tip contact may suddenly move the guide bar upward and backward, which may cause serious injury

CS-310

WARNING!! Read and follow all safety precautions in the instruction manual. Failure to follow instructions could result in serious personal injury.



STOP

100 0065 US0

CS-310 Chain Saw

Labels

ITEM	PART NUMBER	QTY	DESCRIPTION	REMARKS
1	89016739230	1	LABEL - PURGE PUMP	
2	X502000670	2	LABEL - ECHO	
3	X524002190	1	LABEL - BAR & CHAIN	
4	X503009360	1	LABEL - MODEL -- CS-310	
5	89015737330	1	LABEL - STOP	
6	89019130131	1	LABEL - KICK BACK	

SOCKET WRENCH W/SCREWDRIVER (Also Removes Spark Plugs)

1 - 89541010630 -- 17X19mm

2 - X602000020 -- 17X19mm

3 - 89541039131 -- 10X19mm

4 - 89541006960 -- 13X19mm

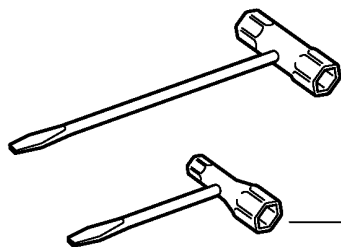

SOCKET WRENCH

5 - X602000031 -- 17X14.5mm

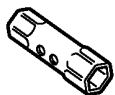

LOCKING ROD

6 - 89751801131 -- 5X120mm



OPEN END WRENCH

7 - 89511200330 -- 8X10mm

8 - 89512220960 -- 17X19mm



9 - 89501505260 -- 10mm



HEX BAR

10 - 89541220960 -- 10mm



HEX KEY

11 - 89561203430 -- 3mm



12 - 89561000130 -- 4mm



13 - 89561100330 -- 5mm



TORX KEY

14 - X605000060 -- T27



SCREWDRIVER

15 - 89581100130 -- 125mm SLOTTED

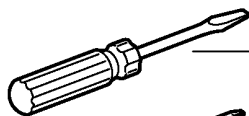

16 - 89581203930 -- 50mm PHILLIPS

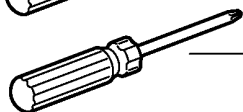

CHUCK KEY

17 - 89757005560

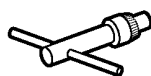

Consult Your Operators Manual For The Tools Used With Your Model

200 0002 000

ITEM	PART NUMBER	QTY	DESCRIPTION	REMARKS
1	89541010630	1	SOCKET WRENCH/SCREWDRIVER	17X19mm
2	X602000020	1	SOCKET WRENCH/SCREWDRIVER	17X19mm
3	89541039131	1	SOCKET WRENCH/SCREWDRIVER	10X19mm
4	89541006960	1	SOCKET WRENCH/SCREWDRIVER	13X19mm
5	X602000031	1	SOCKET WRENCH	17X14.5mm
6	89751801131	1	LOCKING ROD	5X120mm
7	89511200330	1	OPEN END WRENCH	8X10mm
8	89512220960	1	OPEN END WRENCH	17X19mm
9	89501505260	1	OPEN END WRENCH	10mm
10	89541220960	1	HEX BAR	10mm
11	89561203430	1	HEX KEY	3mm
12	89561000130	1	HEX KEY	4mm
13	89561100330	1	HEX KEY	5mm
14	X605000060	1	TORX KEY	T27
15	89581100130	1	SCREWDRIVER	125mm SLOT HEAD
16	89581203930	1	SCREWDRIVER	50mm CROSS HEAD
17	89757005560	1	CHUCK KEY	



Part Number Index

Click The Page Number After Any Part Number To View The Diagram Containing That Part.

Part Number	Page	Part Number	Page	Part Number	Page
-----	5, 7	9305040180	5	V225000030	25
10001116131	25	9403536201	25	V341000110	5
10001315330	25	99944400395	17	V341000120	5
10001411520	25	A021001700	7	V355000140	11
10001504630	25	A051001300	15	V356000430	11
10011311520	25	A056000210	17	V376000450	11
10014212330	19	A160001070	5	V420001790	21
10014319830	17	A172000830	15	V450000070	11
10092735830	5	A200000350	5	V450000700	21
12311003930	7	A202000070	5	V450000710	21
12311337530	7	A206000000	5	V450000720	21
12311403930	7	A225000280	5	V451000470	17
12311605960	7	A226000420	5	V452000220	15
12311802261	7	A241000150	5	V452000250	11
12312239330	7	A300000620	9	V452000260	21
12312409520	7	A310000060	9	V470000810	23
12312703930	7	A313000760	9	V471001560	5
12312715030	7	A356000030	15	V471002170	5
12313002960	7	A365000050	5, 23	V471002190	5
12313304260	7	A409000350	19	V485001070	19
12313404260	7	A411000460	19	V485001080	19
12313609660	7	A425000000	19	V490000400	5
12313903930	7	A426000020	19	V505000010	25
12314203930	7	A427000020	19	V582000050	5
12314926030	7	A440001190	19	V583000120	17
12318139130	5	A506000030	15	V651000001	11
12318509660	7	A514000020	15	V651000011	11
12318609660	7	A551000080	17	V652000040	17
13011005260	23	A551000090	17	V804000000	11
13033832430	5	A552000100	17	V804000020	11
13100437932	5	A556000540	17	V804000030	9
13120507320	5	C022000040	23	V805000000	5, 21
13201309820	5	C300000400	11	V805000010	5, 11, 15, 21
13211501461	23	C309000030	11	V805000040	5
13211544330	5	C320000170	11	V805000180	25
14A0CD3752	13	C328000030	11	V805000210	19
15011716430	19	C334000100	11	V805000220	25
15901019830	19	C345000270	11	X502000670	27
17501203930	17	C400000541	21	X503009360	27
17721403930	11	C410000450	21	X524002190	27
17723435430	15	C411000040	21	X602000020	29
17723661830	15	C450000212	21	X602000031	29
17724704630	15	C454000160	5	X605000060	29
2894901	13	C460000072	21		
43301912330	11	C463000030	5		
43311635430	11	J485000200	5		
43611413930	23	P003000010	7		
43620502832	23	P003000150	7		
89015737330	27	P003001040	7		
89016739230	27	P003001510	7		
89019130131	27	P003002190	7		
89501505260	29	P003002240	7		
89511200330	29	P003002250	7		
89512220960	29	P003002260	7		
89541006960	29	P021005581	23		
89541010630	29	P021005810	17		
89541039131	29	P021015050	25		
89541220960	29	P021015060	25		
89561000130	29	P021015070	25		
89561100330	29	P021015080	25		
89561203430	29	P021015110	11		
89581100130	29	P022001330	15		
89581203930	29	P022005891	15		
89751801131	29	P022008440	15		
89757005560	29	P022022000	15		
90034540025	21	V103000500	5		
90051500008	19	V104000731	9		
90051600005	9	V130000010	5		
90060300005	15	V137000000	15		
90072000018	23	V186000020	23		
90072000022	5	V203000080	15		
91VG52CQ	13	V203000110	11		
93050300098	11	V203000120	9		



Part Description Index

Click The Page Number After Any Part Description To View The Diagram Containing That Part.

<p>A</p> <p>AUTO-OILER ASY.....23</p>	<p>FLANGE NUT 8.....19</p> <p>FLYWHEEL.....19</p>	<p>P</p> <p>PAWL.....15</p> <p>PIN.....5, 11</p> <p>PIN, METERING LEVER.....7</p> <p>PIN, PISTON.....25</p> <p>PIPE, FUEL - 3X5X230mm.....5</p> <p>PIPE, OIL.....23</p> <p>PIPE, PURGE - 3X5X125mm.....5</p> <p>PIPE, RETURN - 3X5X80mm.....5</p> <p>PISTON ASY.....7</p> <p>PISTON KIT.....25</p> <p>PLATE, CLUTCH.....17</p> <p>PLUG.....5</p> <p>PLUG, WELCH.....7</p> <p>PUMP, PURGE.....5</p>
<p>B</p> <p>BALL.....7</p> <p>BAND, BRAKE.....11</p> <p>BEARING, BALL - 6202.....25</p> <p>BEARING, NEEDLE.....17, 25</p> <p>BELLOWS.....5</p> <p>BODY, CARBURETOR.....7</p> <p>BOLT.....9</p> <p>BRACKET, AIR CLEANER.....5</p> <p>BUSHING.....5</p>	<p>G</p> <p>GASKET, EXHAUST.....9</p> <p>GASKET, FUEL PUMP.....7</p> <p>GASKET, INTAKE.....5</p> <p>GASKET, METERING DIAPHRAGM.....7</p> <p>GEAR, BEVEL.....11</p> <p>GEAR, WORM.....17</p> <p>GRIP, STARTER.....15</p> <p>GROMMET.....5, 15, 23</p> <p>GROMMET, OIL.....23</p> <p>GUARD, SPROCKET.....11</p> <p>GUIDE BAR - 14" -- Double-Guard 91.....13</p> <p>GUIDE BAR COVER ASY.....11</p> <p>GUIDE, EXHAUST.....9</p>	<p>R</p> <p>REEL, ROPE.....15</p> <p>REPAIR KIT.....7</p> <p>RETAINER.....5</p> <p>RETAINER, AIR FILTER.....5</p> <p>RETAINER, BELLOWS.....5</p> <p>REWIND SPRING KIT.....15</p> <p>RING, PISTON.....25</p> <p>ROD, CHOKE.....5</p> <p>ROD, THROTTLE.....5</p> <p>ROPE, STARTER - 3.5X900mm.....15</p>
<p>C</p> <p>CAP ASY - BLACK.....23</p> <p>CAP ASY - ORANGE.....5</p> <p>CAP, MIXTURE LIMITER.....7</p> <p>CAP, SPARK PLUG.....19</p> <p>CARBURETOR.....5</p> <p>CARBURETOR -- WT-946.....7</p> <p>CATCHER, PAWL.....15</p> <p>CHUCK KEY.....29</p> <p>CIRCLIP.....7</p> <p>CIRCLIP, PISTON PIN.....25</p> <p>CLIP.....5</p> <p>CLIP, THROTTLE SHAFT.....7</p> <p>CLUTCH ASY.....17</p> <p>CLUTCH KIT.....17</p> <p>CLUTCH SHOE SET.....17</p> <p>COIL, IGNITION.....19</p> <p>COLLAR.....11</p> <p>CONNECTOR.....23</p> <p>CONNECTOR, CAP.....5, 23</p> <p>CONNECTOR, BRAKE.....11</p> <p>COVER, BRAKE.....11</p> <p>COVER, ENGINE.....5</p> <p>COVER, FAN.....15</p> <p>COVER, FUEL PUMP.....7</p> <p>COVER, HANDLE.....21</p> <p>COVER, METERING DIAPHRAGM.....7</p> <p>CRANKCASE SET.....25</p> <p>CRANKSHAFT ASY.....25</p> <p>CUSHION.....21</p>	<p>H</p> <p>HANDLE, FRONT.....21</p> <p>HANDLE, REAR.....21</p> <p>HEX BAR.....29</p> <p>HEX KEY.....29</p> <p>HINGE.....5</p> <p>HUB, CLUTCH.....17</p>	<p>S</p> <p>SAWING CHAIN - 14" -- XtraGUARD.....13</p> <p>SCREEN.....9</p> <p>SCREEN, INLET.....7</p> <p>SCREW.....15</p> <p>SCREW 4X12 - TAPPING.....11</p> <p>SCREW 4X20 - TAPPING.....11</p> <p>SCREW 4X8.....9</p> <p>SCREW 5.....15</p> <p>SCREW 5X16 - TAPPING.....5, 21</p> <p>SCREW 5X20.....19</p> <p>SCREW 5X20 - TAPPING.....5, 11, 15, 21</p> <p>SCREW 5X25.....25</p> <p>SCREW 5X30.....25</p> <p>SCREW 5X55.....5</p> <p>SCREW, CHOKE VALVE.....7</p> <p>SCREW, CLIP.....7</p> <p>SCREW, DIAPHRAGM COVER.....7</p> <p>SCREW, IDLE ADJUST.....7</p> <p>SCREW, METERING LEVER PIN.....7</p> <p>SCREW, PUMP COVER.....7</p> <p>SCREW, THROTTLE LEVER.....7</p> <p>SCREW, THROTTLE VALVE.....7</p> <p>SCREWDRIVER.....29</p> <p>SHAFT, CHOKE.....7</p> <p>SHAFT, THROTTLE.....7</p> <p>SOCKET WRENCH.....29</p> <p>SOCKET WRENCH/SCREWDRIVER.....29</p> <p>SPACER.....11, 15, 19</p> <p>SPACER 8X12X9.....11</p> <p>SPACER, PISTON PIN.....25</p> <p>SPARK PLUG -- BPM-8Y.....19</p> <p>SPARK PLUG -- BPMR-8Y.....19</p> <p>SPRING.....7, 11, 15, 21</p> <p>SPRING PIN 4X25.....21</p> <p>SPRING, CLUTCH.....17</p>
<p>D</p> <p>DEFLECTOR, HEAT.....5</p> <p>DIAPHRAGM, FUEL PUMP.....7</p> <p>DIAPHRAGM, METERING.....7</p> <p>DRIVE, TENSIONER.....11</p> <p>DRUM, CLUTCH.....17</p>	<p>I</p> <p>INSULATOR, INTAKE.....5</p>	
<p>E</p> <p>E RING.....17</p> <p>ENGINE HOUSING ASY.....25</p>	<p>K</p> <p>KICK GUARD KIT.....13</p>	
<p>F</p> <p>FILTER, AIR.....5</p> <p>FILTER, FUEL.....5</p> <p>FILTER, OIL.....23</p> <p>FLANGE NUT.....11</p> <p>FLANGE NUT 5.....9</p>	<p>L</p> <p>LABEL - BAR & CHAIN.....27</p> <p>LABEL - KICK BACK.....27</p> <p>LABEL - ECHO.....27</p> <p>LABEL - MODEL -- CS-310.....27</p> <p>LABEL - PURGE PUMP.....27</p> <p>LABEL - STOP.....27</p> <p>LATCH, ENGINE COVER.....5</p> <p>LEAD, GROUND.....19</p> <p>LEAD, IGNITION.....19</p> <p>LEVER, BRAKE.....11</p> <p>LEVER, FAST IDLE.....7</p> <p>LEVER, METERING.....7</p> <p>LEVER, THROTTLE.....7</p> <p>LOCKING ROD.....29</p> <p>LOCKOUT, THROTTLE.....21</p>	
	<p>M</p> <p>MUFFLER.....9</p>	
	<p>N</p> <p>NEEDLE, MIXTURE ADJUSTMENT.....7</p>	
	<p>O</p> <p>OIL SEAL.....25</p> <p>OPEN END WRENCH.....29</p> <p>O-RING.....23</p> <p>O-RING 22.....5</p>	



Part Description Index (continued)

SPRING, IDLE ADJUST.....7
SPRING, METERING LEVER.....7
SPRING, RETURN.....15
SPRING, THROTTLE RETURN.....7
SPRING, TRIGGER RETURN.....21
STARTER ASY.....15
STUD, GUIDE BAR.....25
SWITCH, IGNITION.....19

T

TENSIONER, CHAIN.....11
TERMINAL, SPARK PLUG CAP.....19
TORX KEY.....29
TRIGGER, THROTTLE.....21

V

VALVE, CHECK.....23
VALVE, CHOKE.....7
VALVE, INLET NEEDLE.....7
VALVE, THROTTLE.....7
VENT ASY.....15

W

WASHER.....7, 11, 17
WASHER 5.....15
WOODRUFF KEY.....19

NOTES



ECHO, INCORPORATED

400 Oakwood Road
Lake Zurich, IL 60047 USA

WWW.ECHO-USA.COM
