



AVAILABLE ATTACHMENTS & ACCESSORIES**Accessories**

103942147 CS Carry Bag

99988800207 CS Removable Nose Case

Guide Bars

14A0CD3752 Guide Bar - 14" -- Standard Width

16A0CD3757 Guide Bar - 16" -- Standard Width

16A0ZD3757 Guide Bar - 16" -- Intenz - Standard Width

18A0CD3762 Guide Bar - 18" -- Standard Width

Sawing Chains

91VG52G Chain - 14"

91VG57G Chain - 16"

91VG62G Chain - 18"

PARTS CATALOG
CS-370 Chain Saw**36.3cc**

SERIAL NUMBERS

S/N: C08913001001 - C08913999999

ECHO, INCORPORATED

400 Oakwood Road Lake Zurich, Illinois 60047 USA

WWW.ECHO-USA.COM



Table of Contents

Click Any Diagram Description Below To View That Diagram.

CS-370 S/N: C08913001001 - C08913999999

Intake, Cylinder Cover, Ignition Switch, Fuel System.....	4
Carburetor -- WT-829.....	6
Exhaust.....	8
Starter.....	10
Ignition, Flywheel.....	12
Chain Brake.....	14
Guide Bar, Sawing Chain, Kick Guard.....	16
Clutch.....	18
Auto-Oiler.....	20
Engine, Short Block -- SB1088.....	22
Handles, Throttle Control, Engine Cover.....	24
Labels.....	26
Tools.....	28
Part Number Index.....	30
Part Description Index.....	31

This Page Intentionally Left Blank

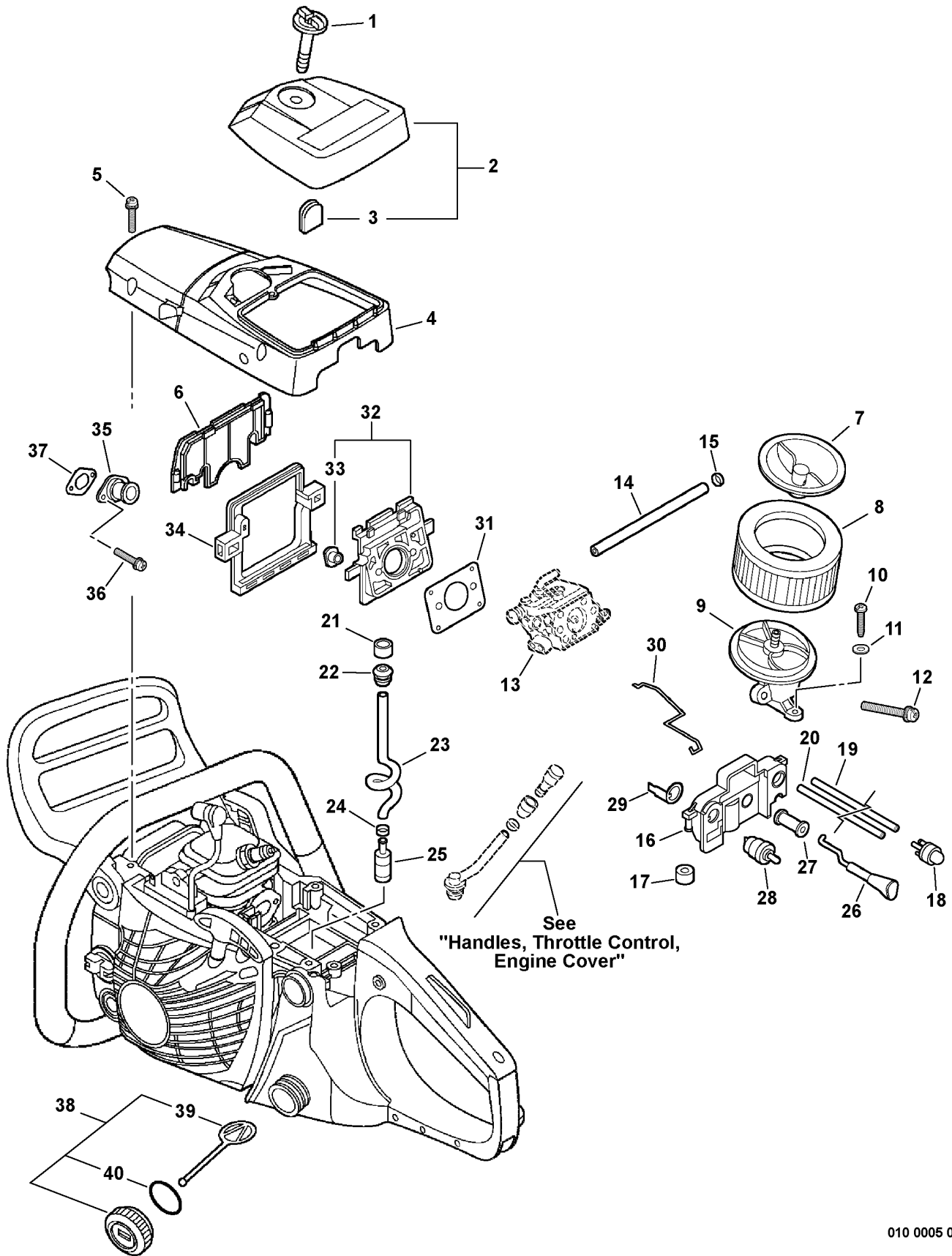

010 0005 00B

ITEM	PART NUMBER	QTY	DESCRIPTION	REMARKS
1	A235000020	1	KNOB, AIR CLEANER LID	
2	P021007153	1	LID, AIR CLEANER	INCLUDES ITEM 3
3	13033832430	1	PLUG, COVER	
4	A160000761	1	COVER, CYLINDER	
5	90023805020	3	SCREW 5X20	
6	A209000000	1	PLATE, INSULATOR	
7	13040538332	1	CAP, AIR CLEANER	
8	13030039730	1	AIR CLEANER ASY	
9	13030139935	1	ADAPTER, INTAKE	
10	90025305020	1	SCREW 5X20	
11	90060000005	1	WASHER	
12	90023805050	2	SCREW 5X50	
13	-----	1	CARBURETOR	
14	V471001600	1	PIPE	
15	13201309820	1	CLIP	
16	A439000145	1	BRACKET, SWITCH	
17	35113439930	2	CUSHION	
18	12318139130	1	PUMP, PRIMER	
19	V471001470	1	PIPE, PRIMER - 3X5X200	REPOWER BULK OPTION: 90014
20	V471001831	1	PIPE, RETURN - 3X5X110	REPOWER BULK OPTION: 90014
21	V475003970	1	TUBE	
22	13211544330	1	GROMMET	
23	13200700760	1	PIPE, FUEL	
24	13201309820	1	CLIP	
25	13120519830	1	FILTER, FUEL	
26	A241000140	1	KNOB, CHOKE	
27	17881014534	1	GROMMET	
28	16340038330	1	SWITCH, IGNITION	
29	V486000021	1	TERMINAL, LEAD - GROUND	
30	C454000100	1	ROD, THROTTLE	
31	V103000280	1	GASKET, INTAKE	
32	13000739931	1	INSULATOR ASY	INCLUDES ITEM 33
33	13002033330	2	NUT	
34	V420001420	1	CUSHION	
35	A202000060	1	ADAPTOR, INTAKE	
36	90023805014	2	SCREW 5X14	
37	V103000290	1	GASKET, INTAKE	
38	P021010600	1	FUEL TANK CAP ASY	INCLUDES ITEMS 39-40
39	A365000050	1	CONNECTOR, CAP	
40	90072000022	1	O-RING 22	

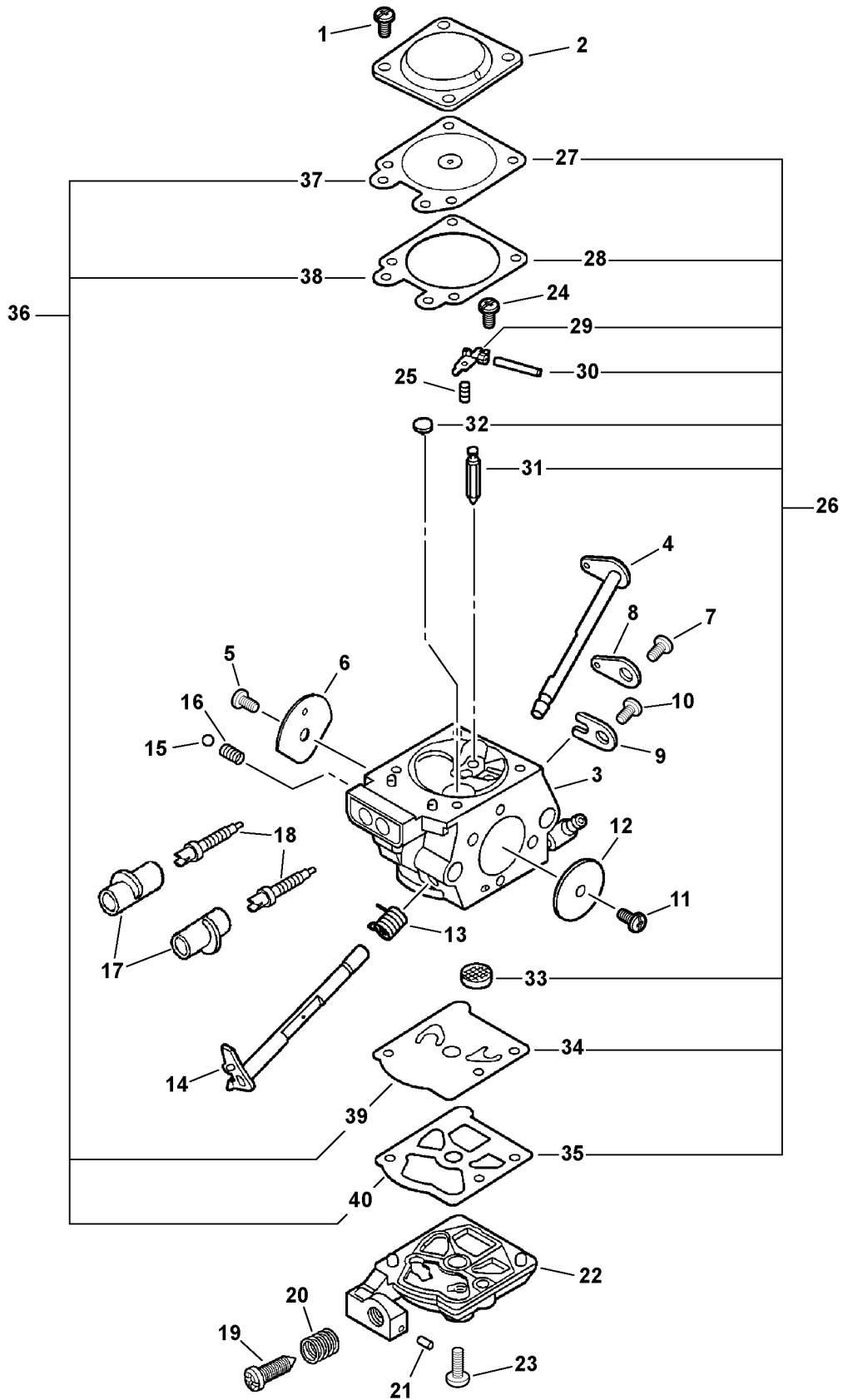

WT829 0000 000

ITEM	PART NUMBER	QTY	DESCRIPTION	REMARKS
	A021001330	1	CARBURETOR -- WT-829	
1	12313002960	4	SCREW, DIAPHRAGM COVER	
2	12314203930	1	COVER, METERING DIAPHRAGM	
3	-----		BODY, CARBURETOR ¹	
4	12313135430	1	SHAFT, CHOKE	
5	12311403930	1	SCREW, CHOKE VALVE	
6	12313237330	1	VALVE, CHOKE	
7	12311403930	1	SCREW, THROTTLE LEVER	
8	P003001520	1	LEVER, THROTTLE	
9	12312703930	1	CLIP, THROTTLE SHAFT	
10	12313002960	4	SCREW, CLIP	
11	12311403930	1	SCREW, THROTTLE VALVE	
12	12311610530	1	VALVE, THROTTLE	
13	12311337530	1	SPRING, THROTTLE RETURN	
14	P003001800	1	SHAFT, THROTTLE	
15	12313510630	1	SPRING, CHOKE FRICTION	
16	12313610630	1	BALL, CHOKE FRICTION	
17	P003000010	2	CAP, MIXTURE LIMITER	
18	12311802261	2	NEEDLE, MIXTURE ADJUSTMENT	
19	12313404260	1	SCREW, IDLE ADJUST	
20	12313304260	1	SPRING, IDLE ADJUST	
21	12317815030	1	PLUG, FRICTION	
22	12312438330	1	COVER, FUEL PUMP	
23	12311003930	1	SCREW, PUMP COVER	
24	12313903930	1	SCREW, METERING LEVER PIN	
25	12312239330	1	SPRING, METERING LEVER	
26	12310004930	1	REPAIR KIT	INCLUDES ITEM 27-35
27	-----	1	DIAPHRAGM, METERING	
28	-----	1	GASKET, METERING DIAPHRAGM	
29	-----	1	LEVER, METERING	
30	-----	1	PIN, METERING LEVER	
31	-----	1	VALVE, INLET NEEDLE	
32	-----	1	PLUG, WELCH	
33	-----	1	SCREEN, INLET	
34	-----	1	DIAPHRAGM, FUEL PUMP	
35	-----	1	GASKET, FUEL PUMP	
36	12310103930	1	DIAPHRAGM/GASKET KIT	INCLUDES ITEM 37-40
37	-----	1	DIAPHRAGM, METERING	
38	-----	1	GASKET, METERING DIAPHRAGM	
39	-----	1	DIAPHRAGM, FUEL PUMP	
40	-----	1	GASKET, FUEL PUMP	

Footnotes

1: NOT AVAILABLE SEPARATELY

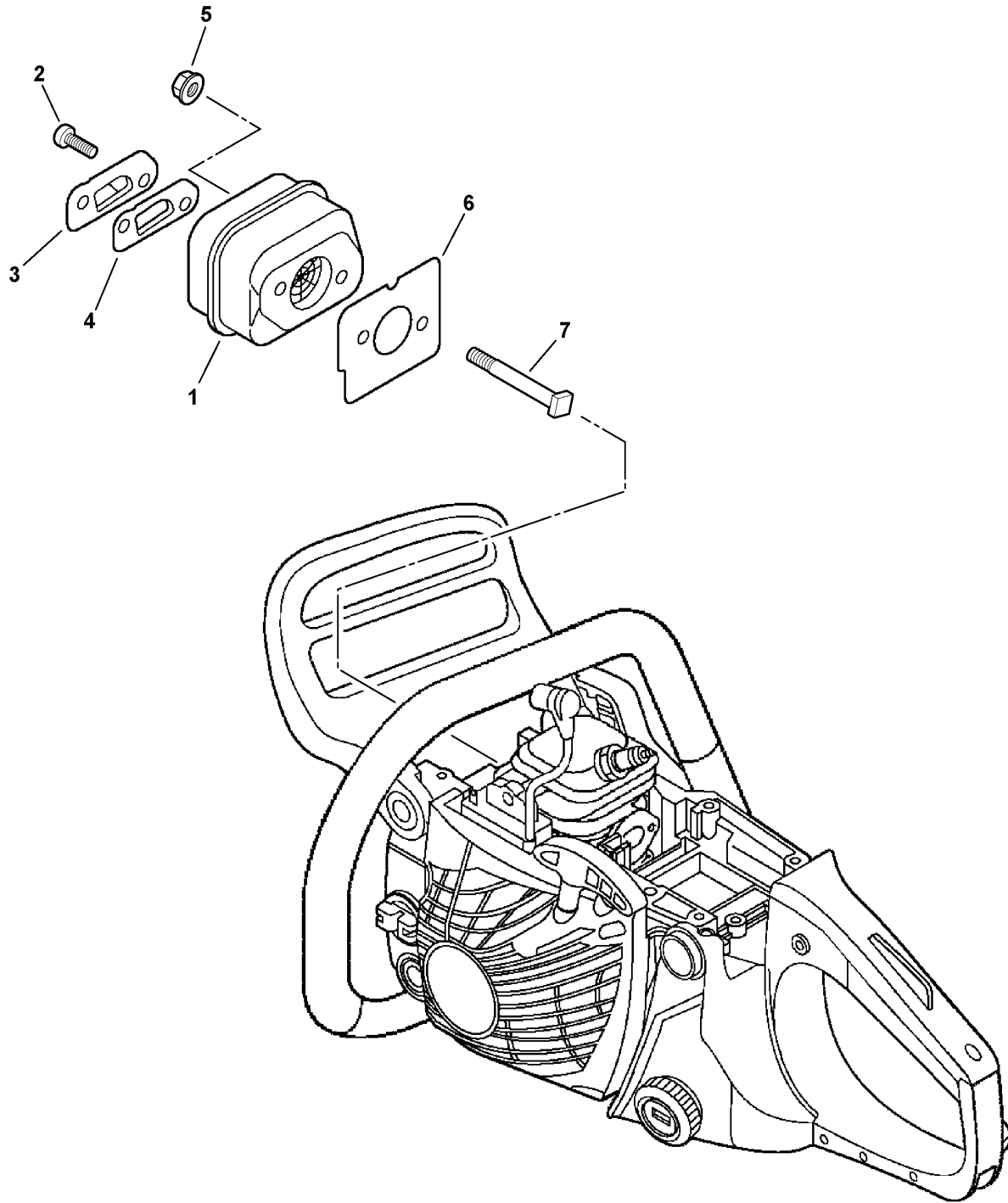

011 0004 000

CS-370 Chain Saw

Exhaust

ITEM	PART NUMBER	QTY	DESCRIPTION	REMARKS
1	A300000620	1	MUFFLER	
2	90022004008	2	SCREW 4X8	
3	A313000760	1	GUIDE, EXHAUST	
4	A310000060	1	SCREEN	
5	90051600005	2	FLANGE NUT	
6	V104000730	1	GASKET, EXHAUST	
7	V203000120	2	BOLT	

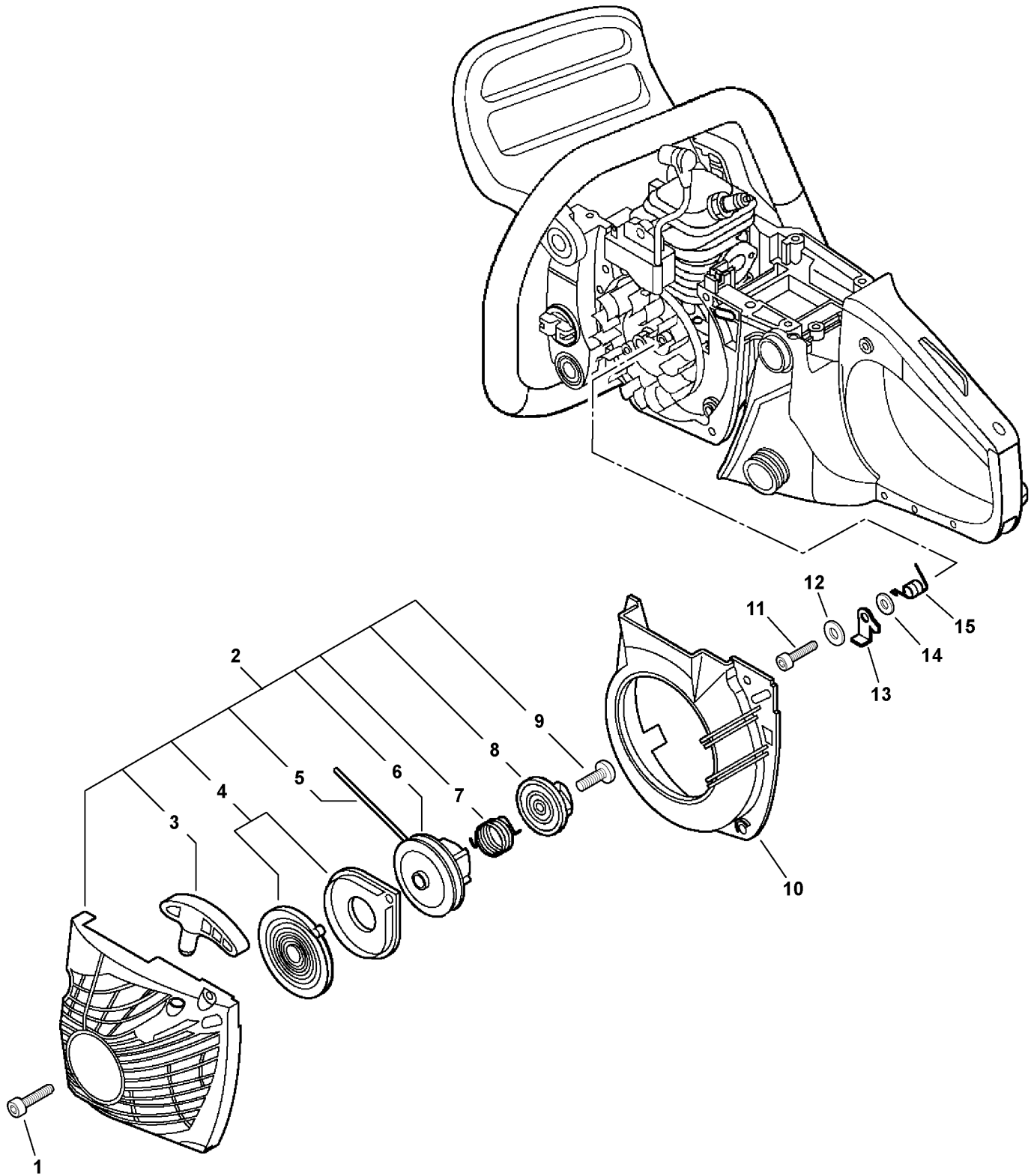

015 0004 000

ITEM	PART NUMBER	QTY	DESCRIPTION	REMARKS
1	9114505020	4	SCREW 5X20	
2	A051000980	1	STARTER ASY	INCLUDES ITEMS 3-9
3	P022005890	1	GRIP, STARTER	
4	P022010440	1	REWIND SPRING KIT	
5	P022008440	1	ROPE, STARTER - 3.5X900mm ¹	
6	A506000030	1	REEL, ROPE	
7	V452000220	1	SPRING	
8	A507000021	1	CATCHER, PAWL	
9	17723661830	1	SCREW	
10	A172000571	1	COVER, FAN	
11	V203000090	2	SCREW 5X14	
12	90060300005	2	WASHER 5	
13	A514000050	2	PAWL	
14	17724704630	2	SPACER	
15	17723435430	2	SPRING, RETURN	

Footnotes

1: BULK OPTION: 99944045000

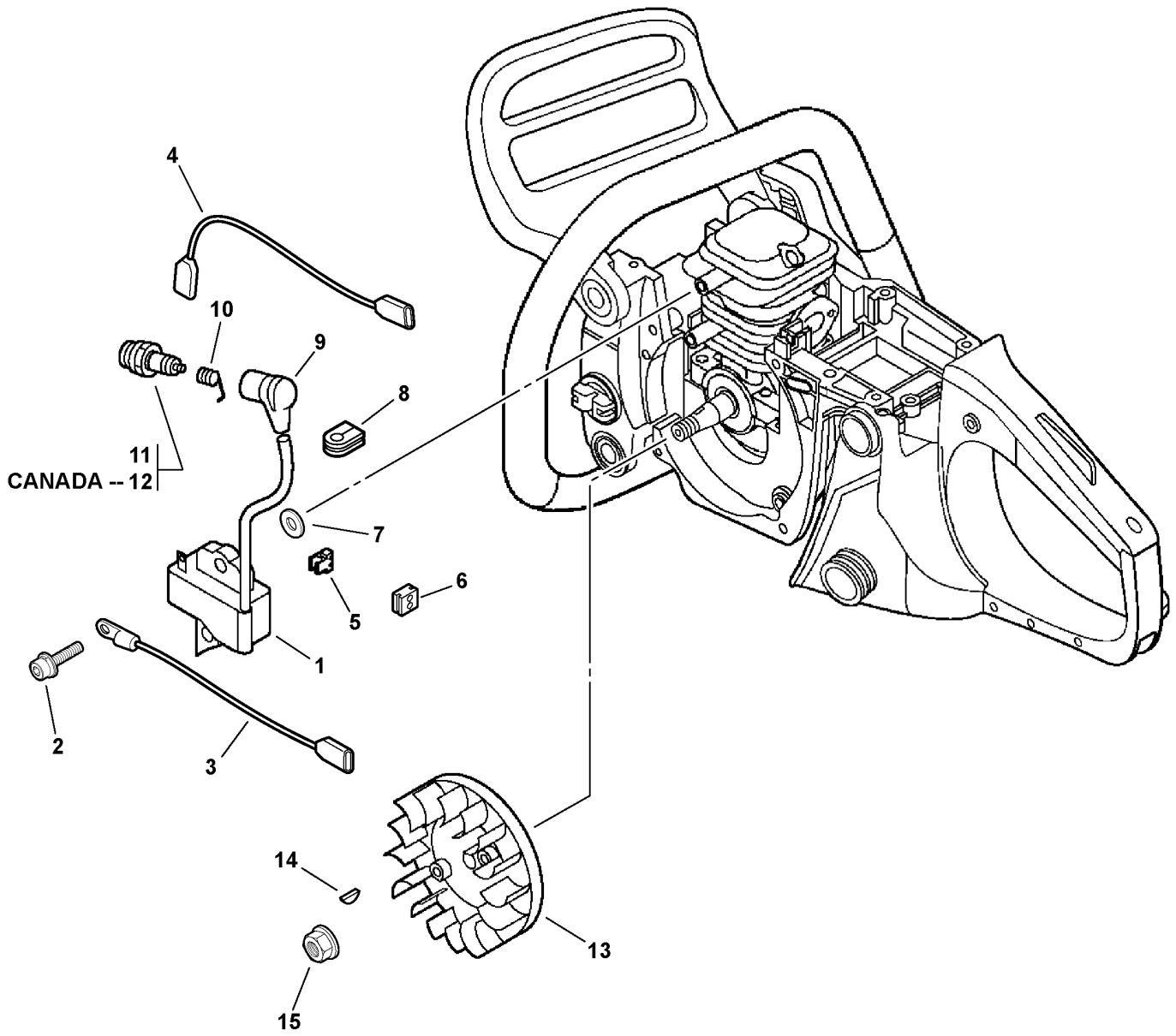

018 0005 000

ITEM	PART NUMBER	QTY	DESCRIPTION	REMARKS
1	A411000264	1	COIL, IGNITION	
2	90016205020	2	SCREW 5X20	
3	V485000620	1	LEAD, GROUND	
4	V485000680	1	LEAD, IGNITION	
5	V490000310	1	CLIP	
6	15011404920	1	BUSHING	
7	15011716430	2	SPACER	
8	V135000010	1	GROMMET	
9	A427000012	1	CAP, SPARK PLUG	
10	A426000010	1	TERMINAL, SPARK PLUG CAP	
11	15901019830	1	SPARK PLUG -- BPM-8Y	
12	A425000000	1	SPARK PLUG -- BPMR-8Y	CANADA MODELS
13	A409000272	1	FLYWHEEL	
14	10014212330	1	WOODRUFF KEY	
15	90051500008	1	FLANGE NUT	

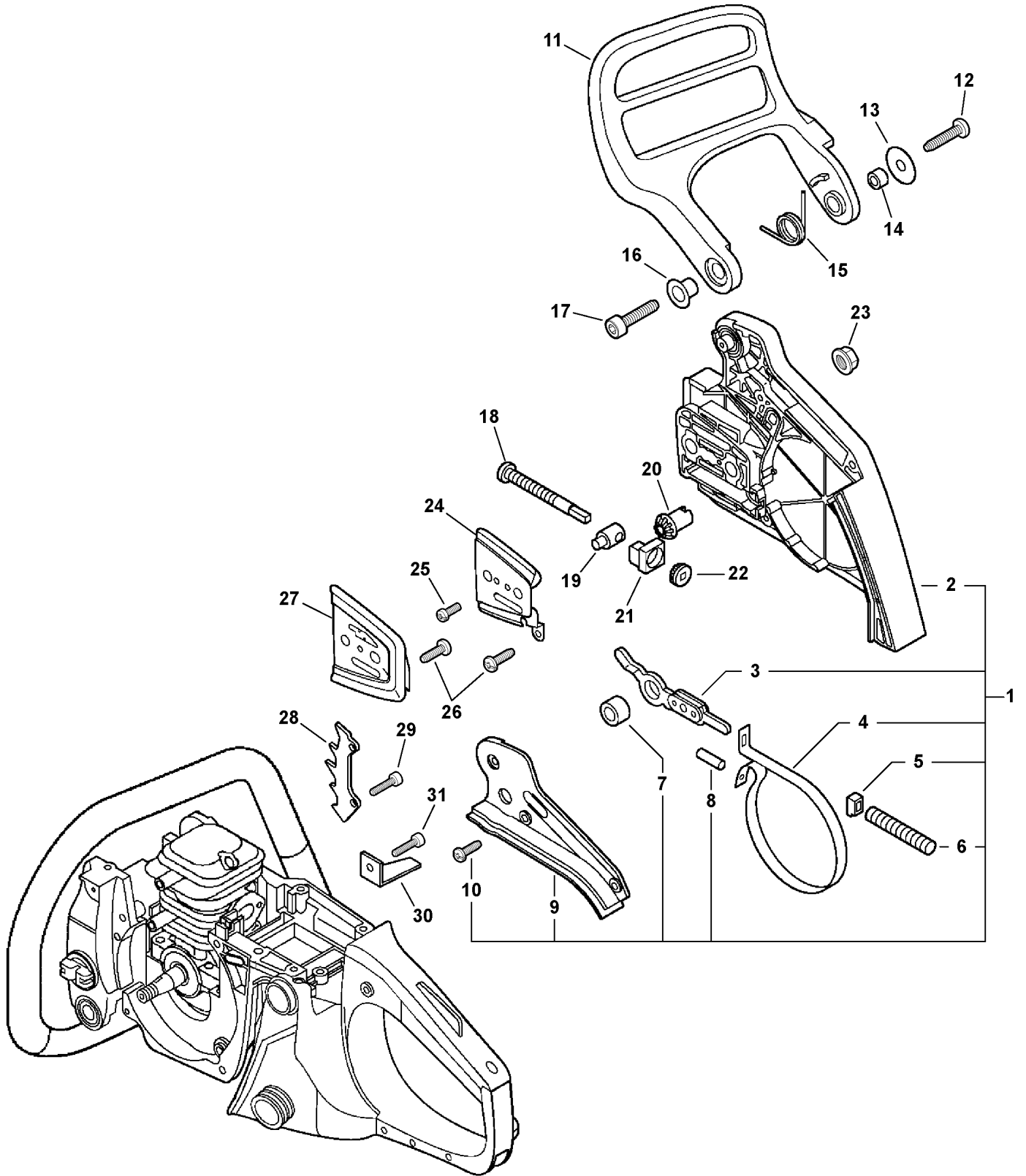

013 0007 000

ITEM	PART NUMBER	QTY	DESCRIPTION	REMARKS
1	C032000282	1	CHAIN BRAKE ASY	INCLUDES ITEMS 2-10
2	C300000312	1	GUARD, SPROCKET	
3	C334000090	1	CONNECTOR, BRAKE	
4	C328000080	1	BAND, BRAKE	
5	V376000450	1	SPACER	
6	V450000070	1	SPRING	
7	43311635430	1	SPACER	
8	9305030098	1	ROLLER	
9	C345000211	1	COVER, BRAKE	
10	V202000060	3	TAPPING SCREW 4X12	
11	C320000111	1	LEVER, BRAKE	
12	V202000070	1	SCREW 4	
13	17721403930	1	WASHER	
14	43311635430	1	SPACER	
15	V452000250	1	SPRING	
16	V356000300	1	COLLAR	
17	9114505016	1	SCREW 5X16	
18	V203000110	1	BOLT	
19	C309000030	1	TENSIONER, CHAIN	
20	V651000001	1	GEAR, BEVEL	
21	V355000270	1	COLLAR	
22	V651000011	1	GEAR, BEVEL	
23	43301912330	2	FLANGE NUT	
24	C305000011	1	PLATE, SPROCKET GUARD	
25	90022003006	1	SCREW 3X6	
26	V202000060	2	TAPPING SCREW 4X12	
27	43301239930	1	PLATE, GUIDE	
28	C304000010	1	BUMPER, SPIKE	
29	9114505020	2	SCREW 5X20	
30	C310000000	1	CATCHER, CHAIN	
31	9114505016	1	SCREW 5X16	

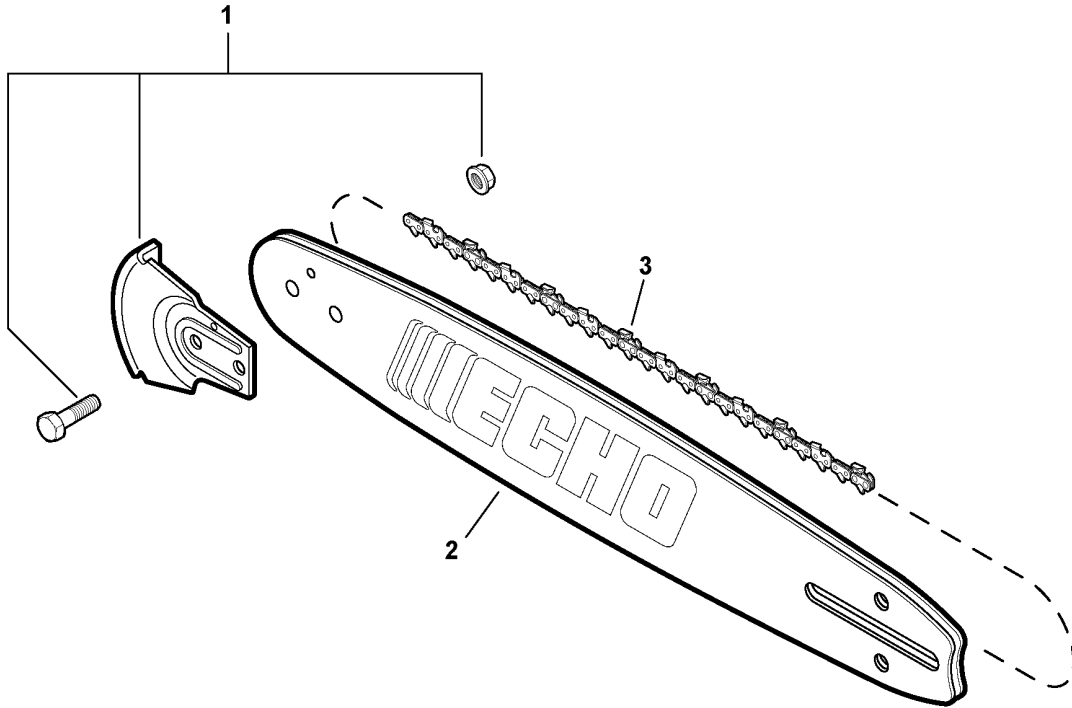

016 0004 000

ITEM	PART NUMBER	QTY	DESCRIPTION	REMARKS
1	2894901	1	KICK GUARD KIT	
2	14A0CD3752	1	GUIDE BAR - 14" -- STANDARD WIDTH	
2	16A0CD3757	1	GUIDE BAR - 16" -- STANDARD WIDTH	
2	18A0CD3762	1	GUIDE BAR - 18" -- STANDARD WIDTH	
3	91VG52G	1	SAWING CHAIN - 14" -- STANDARD WIDTH	
3	91VG57G	1	SAWING CHAIN - 16" -- STANDARD WIDTH	
3	91VG62G	1	SAWING CHAIN - 18" -- STANDARD WIDTH	

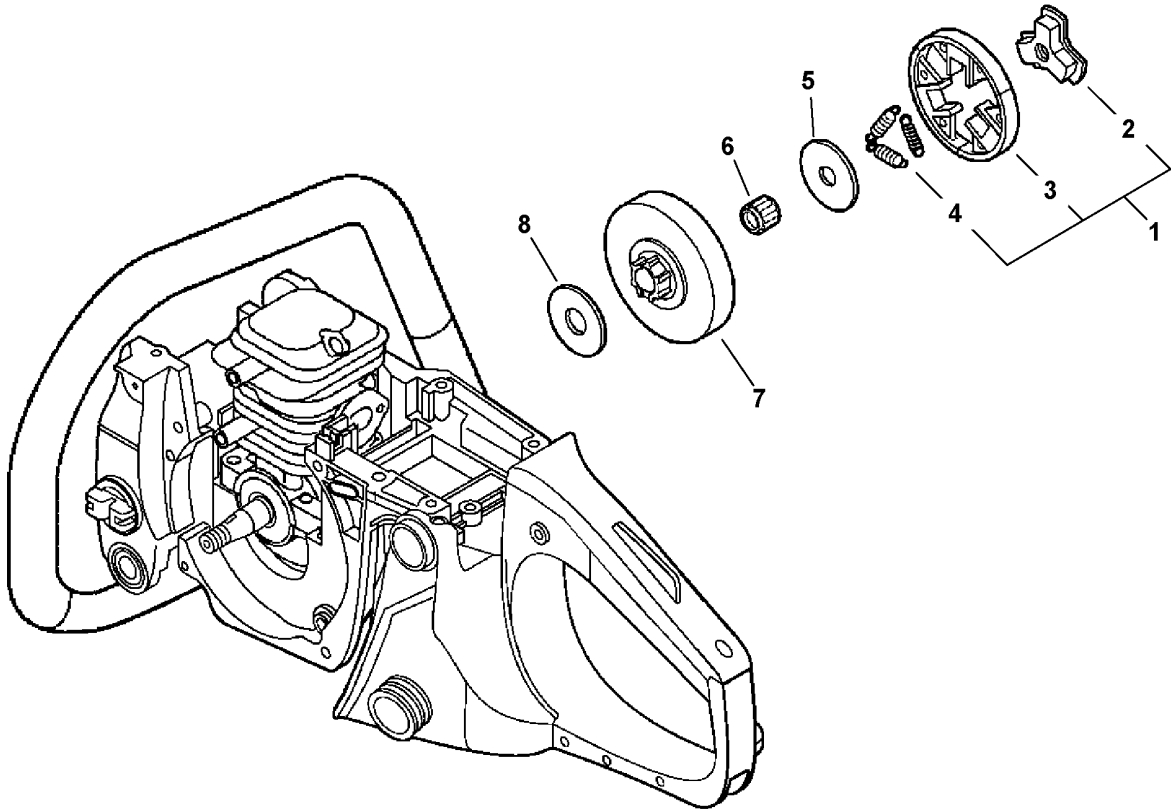

014 0001 00B

ITEM	PART NUMBER	QTY	DESCRIPTION	REMARKS
1	A056000120	1	CLUTCH ASY	INCLUDES ITEM 2-4
2	A552000060	1	HUB, CLUTCH	
3	P021007050	1	CLUTCH SHOE SET	
4	V451000500	3	SPRING, CLUTCH	
5	17501939430	1	PLATE, CLUTCH	
6	17501200831	1	BEARING, NEEDLE	
7	A556000400	1	DRUM, CLUTCH	
8	17501439131	1	WASHER, CLUTCH	

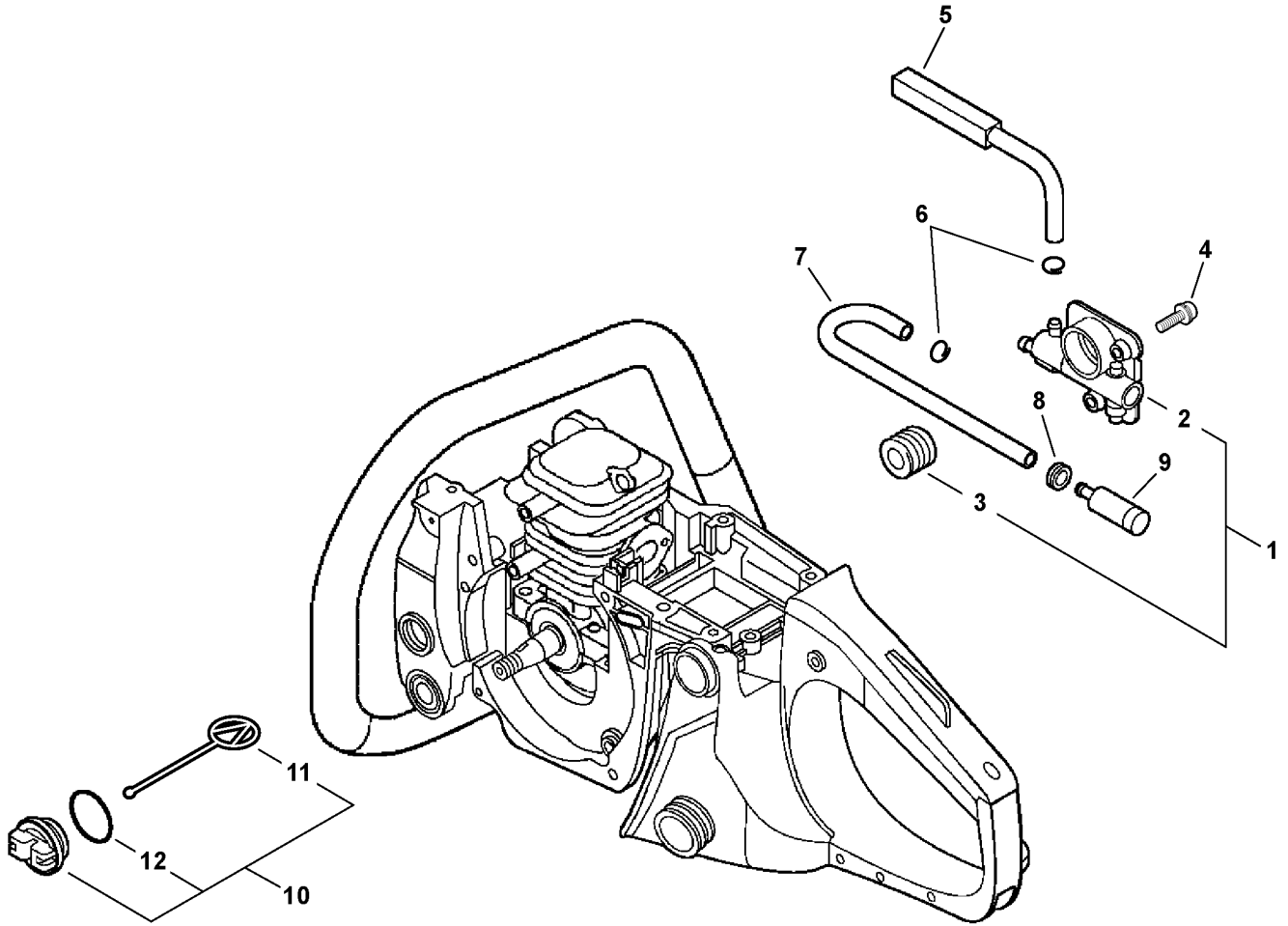

017 0004 000

ITEM	PART NUMBER	QTY	DESCRIPTION	REMARKS
1	P021001980	1	AUTO-OILER ASY	INCLUDES ITEMS 2-3
2	C022000000	1	AUTO-OILER	
3	V652000010	1	GEAR, WORM ¹	
4	90023804012	2	SCREW 4X12	
5	43721039931	1	PIPE	
6	13201326630	2	CLIP	
7	43721035430	1	PIPE	
8	13211512330	1	GROMMET	
9	43620514730	1	FILTER, OIL	
10	P021007630	1	FUEL CAP ASY	INCLUDES ITEMS 11-12
11	A365000050	1	CONNECTOR, CAP	
12	90072100025	1	O-RING	

Footnotes

1: ALSO INCLUDED IN P021009840 - CRANKSHAFT ASY

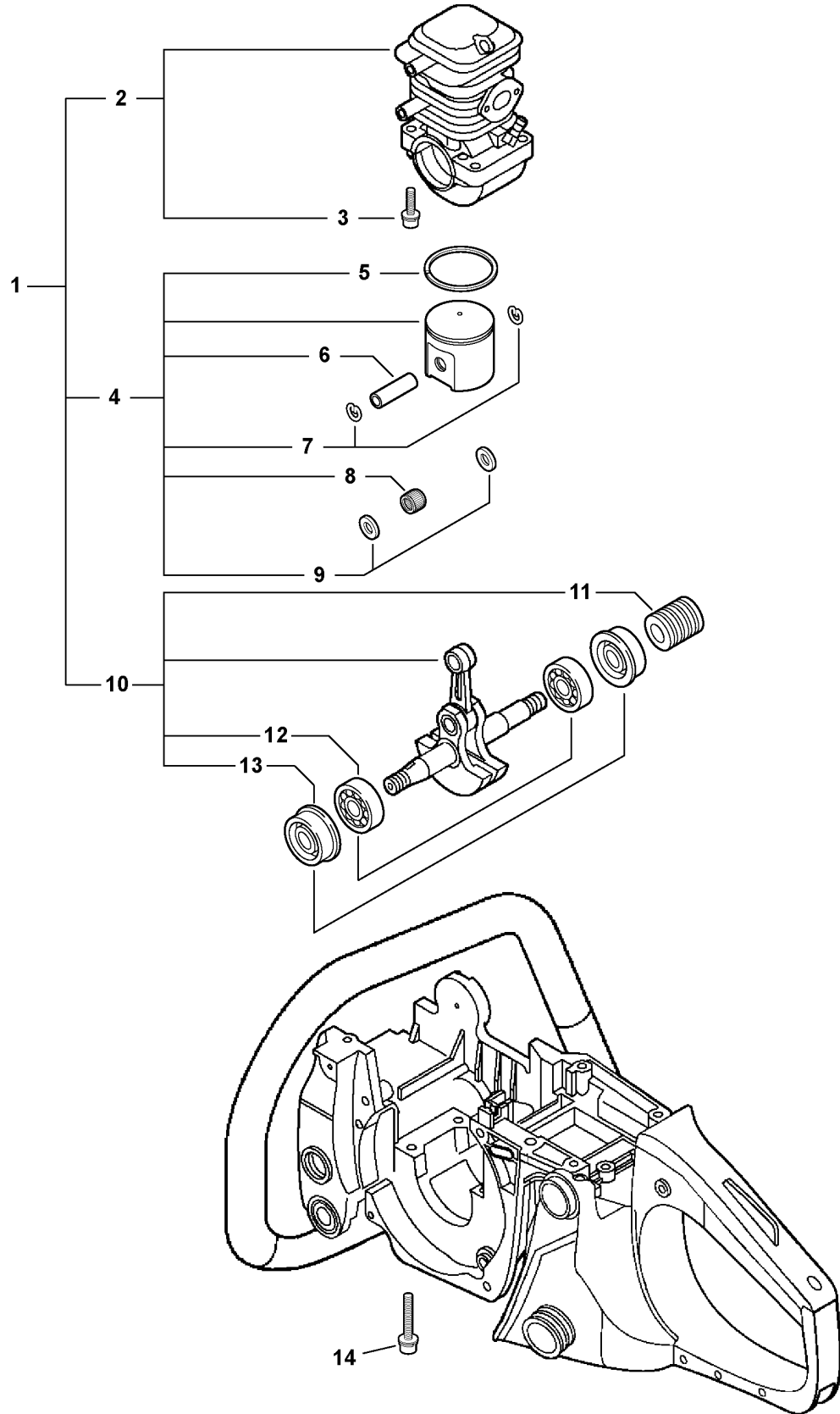

SB1088 0000 000

ITEM	PART NUMBER	QTY	DESCRIPTION	REMARKS
1	SB1088	1	SHORT BLOCK	INCLUDES ITEMS 2-13
2	-----	1	CRANKCASE SET	INCLUDES ITEM 3
3	90016205022	4	SCREW 5X22	
4	P021009830	1	PISTON KIT	INCLUDES ITEMS 5-9
5	A101000110	1	RING, PISTON	
6	10001327430	1	PIN, PISTON	
7	10001503931	2	CIRCLIP, PISTON PIN	
8	10001216131	1	BEARING, NEEDLE	
9	10001453630	2	SPACER, PISTON PIN	
10	-----	1	CRANKSHAFT ASY	INCLUDES ITEMS 11-13
11	V652000010	1	GEAR, WORM ¹	
12	9403536201	2	BEARING, BALL 6201	
13	V505000010	2	OIL SEAL	
14	90016205030	4	SCREW 5X30	

Footnotes

1: ALSO INCLUDED IN P021001980 - AUTO-OILER ASY

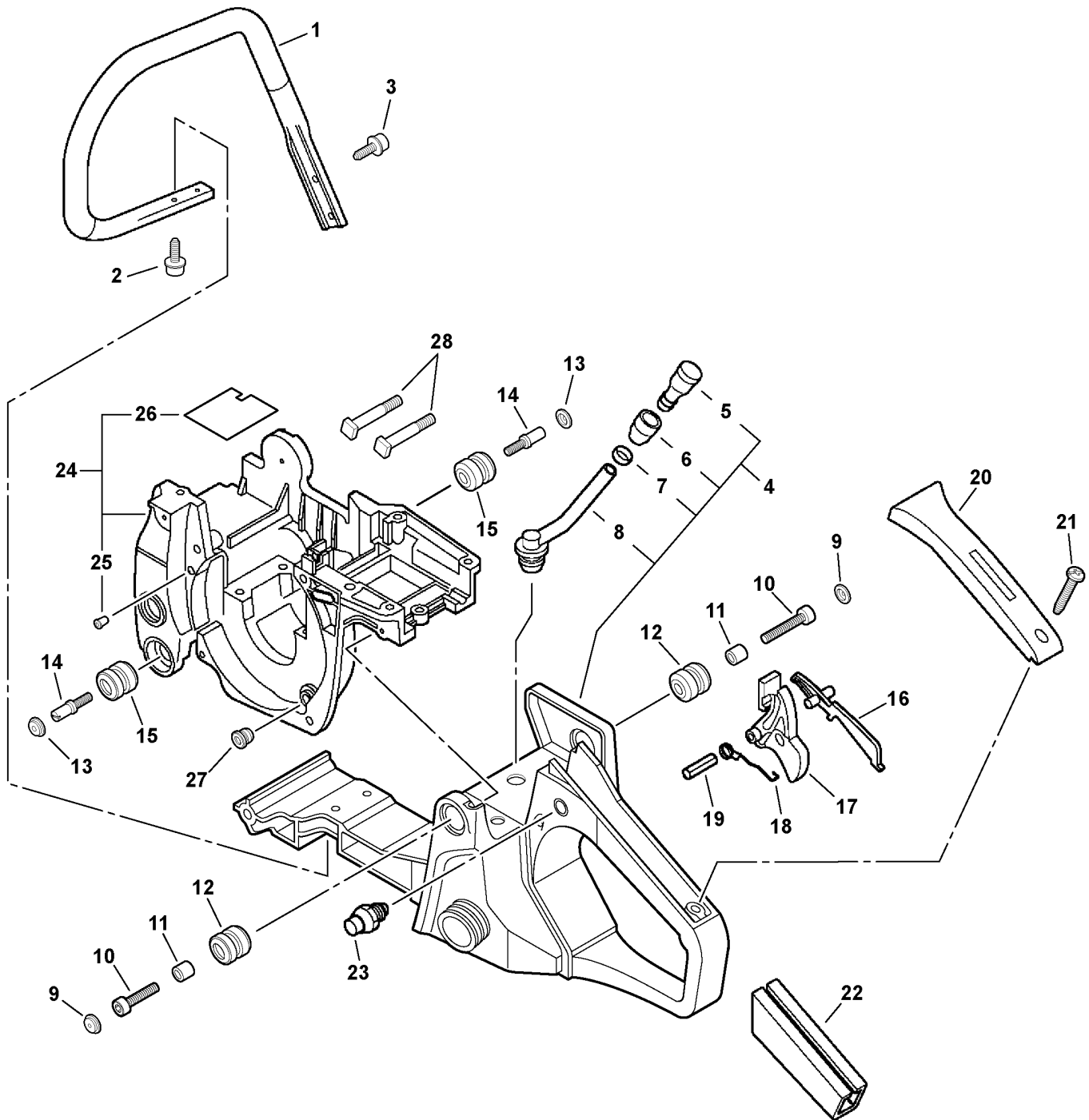

012 0001 00C

ITEM	PART NUMBER	QTY	DESCRIPTION	REMARKS
1	C400000430	1	HANDLE, FRONT	
2	9114505016	2	SCREW 5X16	
3	9114505020	2	SCREW 5X20	
4	P021010590	1	REAR HANDLE SET	INCLUDES ITEMS 5-8
5	A356000030	1	VENT ASY	
6	13132840630	1	COVER, VENT	
7	13201326630	1	CLIP	
8	13201239931	1	PIPE	
9	10091815130	2	CAP	
10	9110004022	2	SCREW 4X22	
11	V352000070	2	COLLAR	
12	V400000050	2	CUSHION	
13	10091815130	2	CAP	
14	10091533930	2	SCREW	
15	10091060030	2	CUSHION	
16	C460000072	1	LOCKOUT, THROTTLE	
17	C450000212	1	TRIGGER, THROTTLE	
18	V452000260	1	SPRING, TRIGGER RETURN	
19	90034540030	1	SPRING PIN 4X30	
20	35115535430	1	COVER, HANDLE	
21	90025304014	1	SCREW 4X14	
22	35111119830	1	GRIP, HANDLE	
23	17830237930	1	LOCK, TRIGGER	
24	P021009855	1	ENGINE COVER ASY	INCLUDES ITEMS 25-26
25	43611413930	1	VALVE, CHECK	
26	V341000050	1	DEFLECTOR, HEAT	
27	V420001250	2	CUSHION	
28	43301119830	2	STUD, GUIDE BAR	



CS-370
 Caution: This saw shall be used only by certified tree service professionals.
 For safe operation follow all safety precautions and instructions in operator's manuals. (Replacement manuals are available from your ECHO dealer.)
 Hold saw firmly with both hands.

ATTENTION
 Lorem ipsum dolor sit amet, consectetur adipiscing elit, sed diam nonummy nibh. Keusimod tincidunt ut laoreet dolore magna aliquam erat volutpat. Ut wisi enim ad minim veniam, quis nostrud exerci tation ullamcorper suscipit lobortis nisl ut aliquip ex. Duis autem vel eum irure dolor in hendrerit in vulputate velit esse molestie consequat, vel illum dolore eu feugiat nulla facilisis at vero eros et accumsan et justo odio.

PURGE PUMP

WARNING
 Note: Lorem ipsum dolor sit amet, consectetur adipiscing elit, sed diam nonummy nibh. Keusimod tincidunt ut laoreet dolore magna aliquam erat volutpat. Ut wisi enim ad minim veniam, quis nostrud exerci tation ullamcorper suscipit lobortis nisl ut aliquip ex. Duis autem vel eum irure dolor in hendrerit in vulputate velit esse molestie consequat, vel illum dolore eu feugiat nulla facilisis at vero eros et accumsan et justo odio.



TO AVOID KICKBACK
 1. Hold the chain saw firmly with both hands.
 2. Don't let the nose of the guide bar contact any obstruction.
 3. Tip contact may suddenly move the guide bar upward and backward, which may cause serious injury.

POUR EVITER LES REBONDISSEMENTS
 1. Eorem ipsum dolor sit amet, consectetur adipiscing elit, sed diam nonummy nibh.
 2. Teusimod tincidunt ut laoreet dolore magna aliquam erat volutpat. Ut wisi enim ad minim veniam, quis nostrud exerci tation.
 3. Tullamcorper suscipit lobortis nisl ut aliquip ex. Duis autem vel eum irure dolor in hendrerit in vulputate velit esse molestie.

REPLACEMENT BAR AND CHAIN
REPLACEMENT DU GUIDE ET DE LA CHAÎNE

GUIDE BAR P/N O.	CHAIN TYPE	CKA
14" 14AED3752	OREGON 91P91V0	52 22.3
15" 15AED3752	OREGON 91P91V0	52 25.1
18" 18AED3752	OREGON 91P91V0	52 22.5

CKA means Computed Kickback Angle
 CKA Signifie angle de rebondissement calculé
 Note: Lorem ipsum dolor sit amet, consectetur adipiscing elit, sed diam nonummy nibh. Keusimod tincidunt ut laoreet dolore magna aliquam erat volutpat. Ut wisi enim ad minim veniam, quis nostrud exerci tation ullamcorper suscipit lobortis nisl ut aliquip ex. Duis autem vel eum irure dolor in hendrerit in vulputate velit esse molestie consequat, vel illum dolore eu feugiat nulla facilisis at vero eros et accumsan et justo odio.
 REMARQUE: Lorem ipsum dolor sit amet, consectetur adipiscing elit, sed diam nonummy nibh. Keusimod tincidunt ut laoreet dolore magna aliquam erat volutpat. Ut wisi enim ad minim veniam, quis nostrud exerci tation ullamcorper suscipit lobortis nisl ut aliquip ex. Duis autem vel eum irure dolor in hendrerit in vulputate velit esse molestie.

CAUTION/ATTENTION
 Lorem ipsum dolor sit amet, consectetur adipiscing elit, sed diam nonummy nibh. Keusimod tincidunt ut laoreet dolore magna aliquam erat volutpat. Ut wisi enim ad minim veniam, quis nostrud exerci tation.



STOP

100 0062 CAN

CS-370 Chain Saw

Labels

ITEM	PART NUMBER	QTY	DESCRIPTION	REMARKS
1	X503007160	1	LABEL - MODEL -- CS-370	
2	89032439630	1	LABEL - ATTENTION	
3	X502002050	1	LABEL - WARNING	
4	X502000020	1	LABEL - ECHO	
5	89016739230	1	LABEL - PURGE PUMP	
6	X505000450	1	LABEL - KICK BACK	
7	X505000460	1	LABEL - KICK BACK (FRENCH)	
8	89017639431	1	LABEL - NOISE (ENGLISH/FRENCH)	
9	89015737330	1	LABEL - STOP	
10	89011849330	1	LABEL - ECHO	
11	X524001720	1	LABEL - BAR & CHAIN	

WRENCH W/SCREWDRIVER (Also Remove Spark Plugs)

1 - 89541010630 -- 17X19mm

2 - X602000020 -- 17X19mm

3 - 89541039131 -- 10X19mm

4 - 89541006960 -- 13X19mm

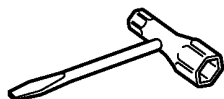
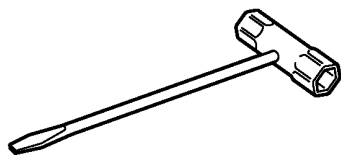

BOX WRENCH

5 - X602000031 -- 17X14.5mm

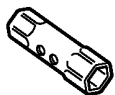

LOCKING BAR

6 - 89751801131 -- 5X120mm



SPANNER

7 - 89511200330 -- 8X10mm

8 - 89512220960 -- 17X19mm



9 - 89501505260 -- 10mm



HEX BAR

10 - 89541220960 -- 10mm



L-WRENCH

11 - 89561203430 -- 3mm



12 - 89561000130 -- 4mm



13 - 89561100330 -- 5mm



SCREWDRIVER

14 - 89581100130 -- 125mm

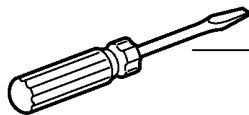

15 - 89581203930 -- 50mm

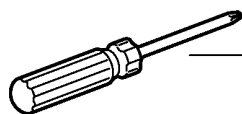

200 0001 000

ITEM	PART NUMBER	QTY	DESCRIPTION	REMARKS
1	89541010630	1	WRENCH/SCREWDRIVER -- 17X19mm	
2	X602000020	1	WRENCH/SCREWDRIVER -- 17X19mm	
3	89541039131	1	WRENCH/SCREWDRIVER -- 10X19mm	
4	89541006960	1	WRENCH/SCREWDRIVER -- 13X19mm	
5	X602000031	1	BOX WRENCH -- 17X14.5mm	
6	89751801131	1	LOCKING BAR -- 5X120mm	
7	89511200330	1	SPANNER -- 8X10mm	
8	89512220960	1	SPANNER -- 17X19mm	
9	89501505260	1	SPANNER -- 10mm	
10	89541220960	1	HEX BAR -- 10mm	
11	89561203430	1	L-WRENCH -- 3mm	
12	89561000130	1	L-WRENCH -- 4mm	
13	89561100330	1	L-WRENCH -- 5mm	
14	89581100130	1	SCREWDRIVER -- 125mm	
15	89581203930	1	SCREWDRIVER -- 50mm	



Part Number Index

Click The Page Number After Any Part Number To View The Diagram Containing That Part.

Part Number	Page	Part Number	Page	Part Number	Page
-----	5, 7, 23	89015737330	27	C305000011	15
10001216131	23	89016739230	27	C309000030	15
10001327430	23	89017639431	27	C310000000	15
10001453630	23	89032439630	27	C320000111	15
10001503931	23	89501505260	29	C328000080	15
10014212330	13	89511200330	29	C334000090	15
10091060030	25	89512220960	29	C345000211	15
10091533930	25	89541006960	29	C400000430	25
10091815130	25	89541010630	29	C450000212	25
12310004930	7	89541039131	29	C454000100	5
12310103930	7	89541220960	29	C460000072	25
12311003930	7	89561000130	29	P003000010	7
12311337530	7	89561100330	29	P003001520	7
12311403930	7	89561203430	29	P003001800	7
12311610530	7	89581100130	29	P021001980	21
12311802261	7	89581203930	29	P021007050	19
12312239330	7	89751801131	29	P021007153	5
12312438330	7	90016205020	13	P021007630	21
12312703930	7	90016205022	23	P021009830	23
12313002960	7	90016205030	23	P021009855	25
12313135430	7	90022003006	15	P021010590	25
12313237330	7	90022004008	9	P021010600	5
12313304260	7	90023804012	21	P022005890	11
12313404260	7	90023805014	5	P022008440	11
12313510630	7	90023805020	5	P022010440	11
12313610630	7	90023805050	5	SB1088	23
12313903930	7	90025304014	25	V103000280	5
12314203930	7	90025305020	5	V103000290	5
12317815030	7	90034540030	25	V104000730	9
12318139130	5	90051500008	13	V135000010	13
13000739931	5	90051600005	9	V202000060	15
13002033330	5	90060000005	5	V202000070	15
13030039730	5	90060300005	11	V203000090	11
13030139935	5	90072000022	5	V203000110	15
13033832430	5	90072100025	21	V203000120	9
13040538332	5	9110004022	25	V341000050	25
13120519830	5	9114505016	15, 25	V352000070	25
13132840630	25	9114505020	11, 15, 25	V355000270	15
13200700760	5	91VG52G	17	V356000300	15
13201239931	25	91VG57G	17	V376000450	15
13201309820	5	91VG62G	17	V400000050	25
13201326630	21, 25	9305030098	15	V420001250	25
13211512330	21	9403536201	23	V420001420	5
13211544330	5	A021001330	7	V450000070	15
14A0CD3752	17	A051000980	11	V451000500	19
15011404920	13	A056000120	19	V452000220	11
15011716430	13	A101000110	23	V452000250	15
15901019830	13	A160000761	5	V452000260	25
16340038330	5	A172000571	11	V471001470	5
16A0CD3757	17	A202000060	5	V471001600	5
17501200831	19	A209000000	5	V471001831	5
17501439131	19	A235000020	5	V475003970	5
17501939430	19	A241000140	5	V485000620	13
17721403930	15	A300000620	9	V485000680	13
17723435430	11	A310000060	9	V486000021	5
17723661830	11	A313000760	9	V490000310	13
17724704630	11	A356000030	25	V505000010	23
17830237930	25	A365000050	5, 21	V651000001	15
17881014534	5	A409000272	13	V651000011	15
18A0CD3762	17	A411000264	13	V652000010	21, 23
2894901	17	A425000000	13	X502000020	27
35111119830	25	A426000010	13	X502002050	27
35113439930	5	A427000012	13	X503007160	27
35115535430	25	A439000145	5	X505000450	27
43301119830	25	A506000030	11	X505000460	27
43301239930	15	A507000021	11	X524001720	27
43301912330	15	A514000050	11	X602000020	29
43311635430	15	A552000060	19	X602000031	29
43611413930	25	A556000400	19		
43620514730	21	C022000000	21		
43721035430	21	C032000282	15		
43721039931	21	C300000312	15		
89011849330	27	C304000010	15		



Part Description Index

Click The Page Number After Any Part Description To View The Diagram Containing That Part.

A

ADAPTER, INTAKE.....5
 ADAPTOR, INTAKE.....5
 AIR CLEANER ASY.....5
 AUTO-OILER.....21
 AUTO-OILER ASY.....21

B

BALL, CHOKE FRICTION.....7
 BAND, BRAKE.....15
 BEARING, BALL 6201.....23
 BEARING, NEEDLE.....19, 23
 BODY, CARBURETOR.....7
 BOLT.....9, 15
 BOX WRENCH -- 17X14.5mm.....29
 BRACKET, SWITCH.....5
 BUMPER, SPIKE.....15
 BUSHING.....13

C

CAP.....25
 CAP, AIR CLEANER.....5
 CAP, MIXTURE LIMITER.....7
 CAP, SPARK PLUG.....13
 CARBURETOR.....5
 CARBURETOR -- WT-829.....7
 CATCHER, CHAIN.....15
 CATCHER, PAWL.....11
 CHAIN BRAKE ASY.....15
 CIRCLIP, PISTON PIN.....23
 CLIP.....5, 13, 21, 25
 CLIP, THROTTLE SHAFT.....7
 CLUTCH ASY.....19
 CLUTCH SHOE SET.....19
 COIL, IGNITION.....13
 COLLAR.....15, 25
 CONNECTOR, CAP.....5, 21
 CONNECTOR, BRAKE.....15
 COVER, BRAKE.....15
 COVER, CYLINDER.....5
 COVER, FAN.....11
 COVER, FUEL PUMP.....7
 COVER, HANDLE.....25
 COVER, METERING DIAPHRAGM.....7
 COVER, VENT.....25
 CRANKCASE SET.....23
 CRANKSHAFT ASY.....23
 CUSHION.....5, 25

D

DEFLECTOR, HEAT.....25
 DIAPHRAGM, FUEL PUMP.....7
 DIAPHRAGM, METERING.....7
 DIAPHRAGM/GASKET KIT.....7
 DRUM, CLUTCH.....19

E

ENGINE COVER ASY.....25

F

FILTER, FUEL.....5
 FILTER, OIL.....21

FLANGE NUT.....9, 13, 15
 FLYWHEEL.....13
 FUEL CAP ASY.....21
 FUEL TANK CAP ASY.....5

G

GASKET, EXHAUST.....9
 GASKET, FUEL PUMP.....7
 GASKET, INTAKE.....5
 GASKET, METERING DIAPHRAGM.....7
 GEAR, BEVEL.....15
 GEAR, WORM.....21, 23
 GRIP, HANDLE.....25
 GRIP, STARTER.....11
 GROMMET.....5, 13, 21
 GUARD, SPROCKET.....15
 GUIDE BAR - 14" -- STANDARD WIDTH.....17
 GUIDE BAR - 16" -- STANDARD WIDTH.....17
 GUIDE BAR - 18" -- STANDARD WIDTH.....17
 GUIDE, EXHAUST.....9

H

HANDLE, FRONT.....25
 HEX BAR -- 10mm.....29
 HUB, CLUTCH.....19

I

INSULATOR ASY.....5

K

KICK GUARD KIT.....17
 KNOB, AIR CLEANER LID.....5
 KNOB, CHOKE.....5

L

LABEL - ATTENTION.....27
 LABEL - BAR & CHAIN.....27
 LABEL - ECHO.....27
 LABEL - KICK BACK.....27
 LABEL - KICK BACK (FRENCH).....27
 LABEL - MODEL -- CS-370.....27
 LABEL - NOISE (ENGLISH/FRENCH).....27
 LABEL - PURGE PUMP.....27
 LABEL - STOP.....27
 LABEL - WARNING.....27
 LEAD, GROUND.....13
 LEAD, IGNITION.....13
 LEVER, BRAKE.....15
 LEVER, METERING.....7
 LEVER, THROTTLE.....7
 LID, AIR CLEANER.....5
 LOCK, TRIGGER.....25
 LOCKING BAR -- 5X120mm.....29
 LOCKOUT, THROTTLE.....25
 L-WRENCH -- 3mm.....29
 L-WRENCH -- 4mm.....29
 L-WRENCH -- 5mm.....29

M

MUFFLER.....9

N

NEEDLE, MIXTURE ADJUSTMENT.....7

NUT.....5

O

OIL SEAL.....23
 O-RING.....21
 O-RING 22.....5

P

PAWL.....11
 PIN, METERING LEVER.....7
 PIN, PISTON.....23
 PIPE.....5, 21, 25
 PIPE, FUEL.....5
 PIPE, PRIMER - 3X5X200.....5
 PIPE, RETURN - 3X5X110.....5
 PISTON KIT.....23
 PLATE, CLUTCH.....19
 PLATE, GUIDE.....15
 PLATE, INSULATOR.....5
 PLATE, SPROCKET GUARD.....15
 PLUG, COVER.....5
 PLUG, FRICTION.....7
 PLUG, WELCH.....7
 PUMP, PRIMER.....5

R

REAR HANDLE SET.....25
 REEL, ROPE.....11
 REPAIR KIT.....7
 REWIND SPRING KIT.....11
 RING, PISTON.....23
 ROD, THROTTLE.....5
 ROLLER.....15
 ROPE, STARTER - 3.5X900mm.....11

S

SAWING CHAIN - 14" -- STANDARD WIDTH.....17
 SAWING CHAIN - 16" -- STANDARD WIDTH.....17
 SAWING CHAIN - 18" -- STANDARD WIDTH.....17
 SCREEN.....9
 SCREEN, INLET.....7
 SCREW.....11, 25
 SCREW 3X6.....15
 SCREW 4.....15
 SCREW 4X12.....21
 SCREW 4X14.....25
 SCREW 4X22.....25
 SCREW 4X8.....9
 SCREW 5X14.....5, 11
 SCREW 5X16.....15, 25
 SCREW 5X20.....5, 11, 13, 15, 25
 SCREW 5X22.....23
 SCREW 5X30.....23
 SCREW 5X50.....5
 SCREW, CHOKE VALVE.....7
 SCREW, CLIP.....7
 SCREW, DIAPHRAGM COVER.....7
 SCREW, IDLE ADJUST.....7
 SCREW, METERING LEVER PIN.....7
 SCREW, PUMP COVER.....7
 SCREW, THROTTLE LEVER.....7



Part Description Index (continued)

SCREW, THROTTLE VALVE.....7
 SCREWDRIVER -- 125mm.....29
 SCREWDRIVER -- 50mm.....29
 SHAFT, CHOKE.....7
 SHAFT, THROTTLE.....7
 SHORT BLOCK.....23
 SPACER.....11, 13, 15
 SPACER, PISTON PIN.....23
 SPANNER -- 10mm.....29
 SPANNER -- 17X19mm.....29
 SPANNER -- 8X10mm.....29
 SPARK PLUG -- BPM-8Y.....13
 SPARK PLUG -- BPMR-8Y.....13
 SPRING.....11, 15
 SPRING PIN 4X30.....25
 SPRING, CHOKE FRICTION.....7
 SPRING, CLUTCH.....19
 SPRING, IDLE ADJUST.....7
 SPRING, METERING LEVER.....7
 SPRING, RETURN.....11
 SPRING, THROTTLE RETURN.....7
 SPRING, TRIGGER RETURN.....25
 STARTER ASY.....11
 STUD, GUIDE BAR.....25
 SWITCH, IGNITION.....5

T

TAPPING SCREW 4X12.....15
 TENSIONER, CHAIN.....15
 TERMINAL, LEAD - GROUND.....5
 TERMINAL, SPARK PLUG CAP.....13
 TRIGGER, THROTTLE.....25
 TUBE.....5

V

VALVE, CHECK.....25
 VALVE, CHOKE.....7
 VALVE, INLET NEEDLE.....7
 VALVE, THROTTLE.....7
 VENT ASY.....25

W

WASHER.....5, 15
 WASHER 5.....11
 WASHER, CLUTCH.....19
 WOODRUFF KEY.....13
 WRENCH/SCREWDRIVER -- 10X19mm.....29
 WRENCH/SCREWDRIVER -- 13X19mm.....29
 WRENCH/SCREWDRIVER -- 17X19mm.....29

NOTES



ECHO, INCORPORATED

400 Oakwood Road
Lake Zurich, IL 60047 USA

WWW.ECHO-USA.COM

ECHO Parts