



---

## OPTIONAL ATTACHMENTS & ACCESSORIES

### Accessories

103942147	CS Carry Bag
89850308032	Bar & Chain Cover - 17"
89850308033	Bar & Chain Cover - 20"
99988800207	CS Removable Nose Case
99988801205	CS Fixed Nose Case

### Guide Bars

16F0MD3366	Guide Bar - 16" (.050" Ga) -- Micro-Lite Pro
18F0MD3372	Guide Bar - 18" (.050" Ga) -- Micro-Lite Pro
20F0AD3378	Guide Bar - 20" (.050" Ga) -- ProAm Double Guard

### Sawing Chains

33SL78G	Sawing Chain - 20" (.050" Ga) -- Pro Guard
95VP66G	Sawing Chain - 16" (.050" Ga) -- Micro-Lite
95VP72G	Sawing Chain - 18" (.050" Ga) -- Micro-Lite

# PARTS CATALOG

## CS-530 Chain Saw

**50.1cc**

### SERIAL NUMBERS

S/N: C02803001001 - C02803999999

**ECHO, INCORPORATED**

400 Oakwood Road Lake Zurich, Illinois 60047 USA

WWW.ECHO-USA.COM



# Table of Contents

---

Click Any Diagram Description Below To View That Diagram.

## **CS-530 S/N: C02803001001 - C02803999999**

Engine Cover, Intake, Fuel System, Ignition Switch.....	4
Carburetor -- WT-908.....	6
Exhaust.....	8
Chain Brake S/N: C02803001001 - C02803001300.....	10
Chain Brake S/N: C02803001301 - C02803999999.....	12
Guide Bar, Sawing Chain, Kick Guard.....	14
Clutch.....	16
Starter.....	18
Ignition.....	20
Handles, Throttle Control.....	22
Auto-Oiler, Oil Tank.....	24
Engine, Short Block -- SB1080, Engine Cover.....	26
Labels.....	28
Tools.....	30
Part Number Index.....	32
Part Description Index.....	33

***This Page Intentionally Left Blank***

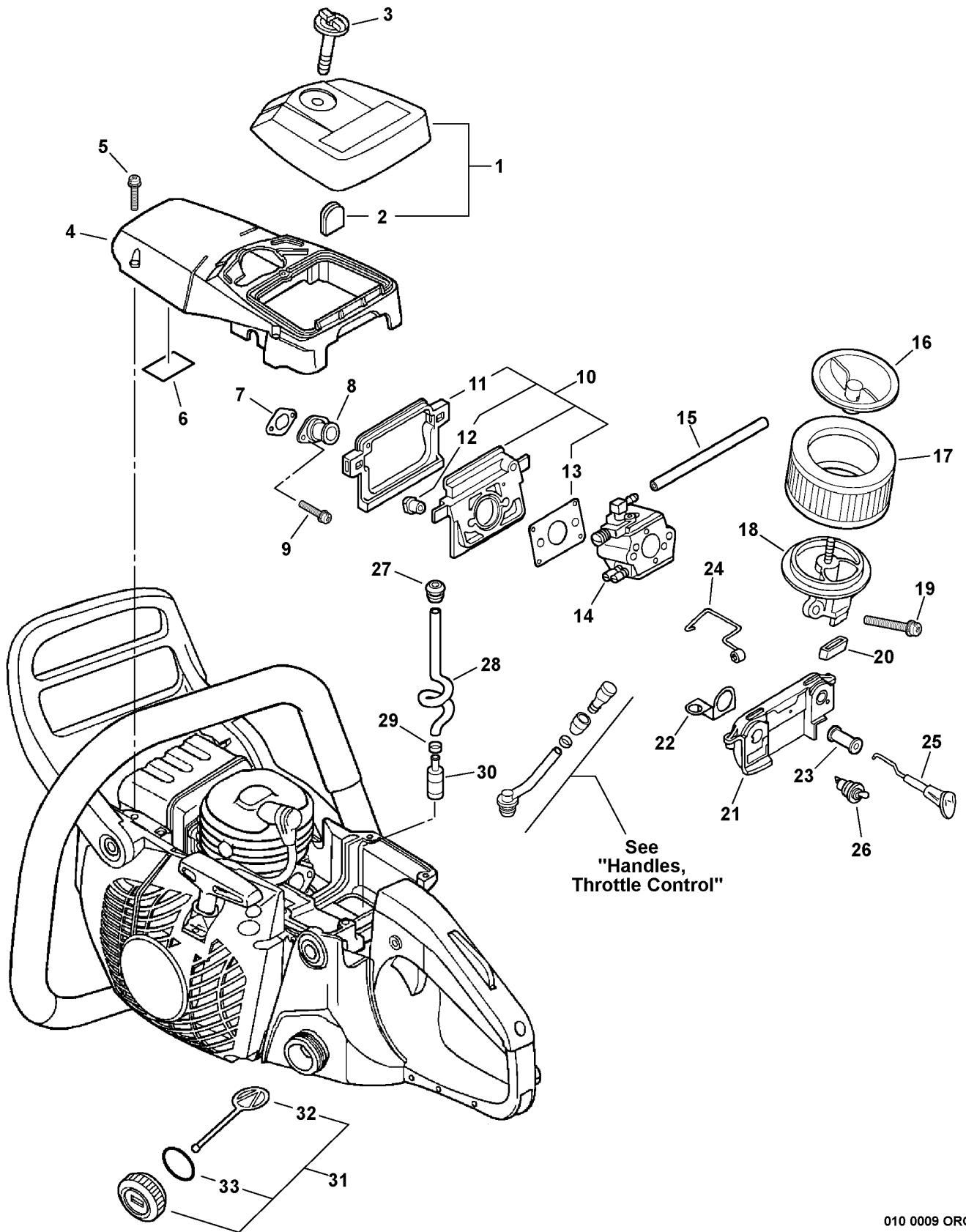

010 0009 ORG

ITEM	PART NUMBER	QTY	DESCRIPTION	REMARKS
1	P021007153	1	AIR CLEANER COVER KIT	INCLUDES ITEM 2
2	13033832430	1	PLUG	
3	A235000020	1	KNOB, AIR CLEANER LID	
4	A160000950	1	COVER, ENGINE	
5	16389038330	3	SCREW 5	
6	10152035430	1	DEFLECTOR, HEAT	
7	13001639930	1	GASKET, INTAKE	
8	13051039932	1	ADAPTER, INTAKE	
9	90023805012	2	SCREW 5X12	
10	13000038331	1	INTAKE INSULATOR KIT	INCLUDES ITEMS 11-13
11	V420001130	1	CUSHION	
12	13002033330	2	NUT	
13	13001038330	1	GASKET, INTAKE	
14	-----	1	CARBURETOR	See Carburetor Diagram For Additional Information
15	13011038330	1	PIPE, IMPULSE	
16	13040538332	1	CAP, AIR FILTER	
17	13031038331	1	FILTER, AIR	
18	A204000004	1	ELBOW, CARBURETOR	
19	90016205050	2	SCREW 5X50	
20	13043038330	1	CUSHION	
21	16381038933	1	BRACKET, SWITCH	
22	16341338930	1	TERMINAL, SWITCH	
23	17881014534	1	GROMMET	
24	C454000150	1	ROD, THROTTLE	
25	A241000101	1	ROD, CHOKE	
26	16340038330	1	SWITCH, IGNITION	
27	13211504920	1	GROMMET	
28	13201038331	1	PIPE, FUEL - SPIRAL	
29	13201326630	1	CLIP	
30	13120519830	1	FILTER, FUEL	
31	P021010600	1	CAP ASY	INCLUDES ITEMS 32-33
32	A365000050	1	CONNECTOR, FUEL TANK CAP	
33	90072000022	1	O-RING 22	

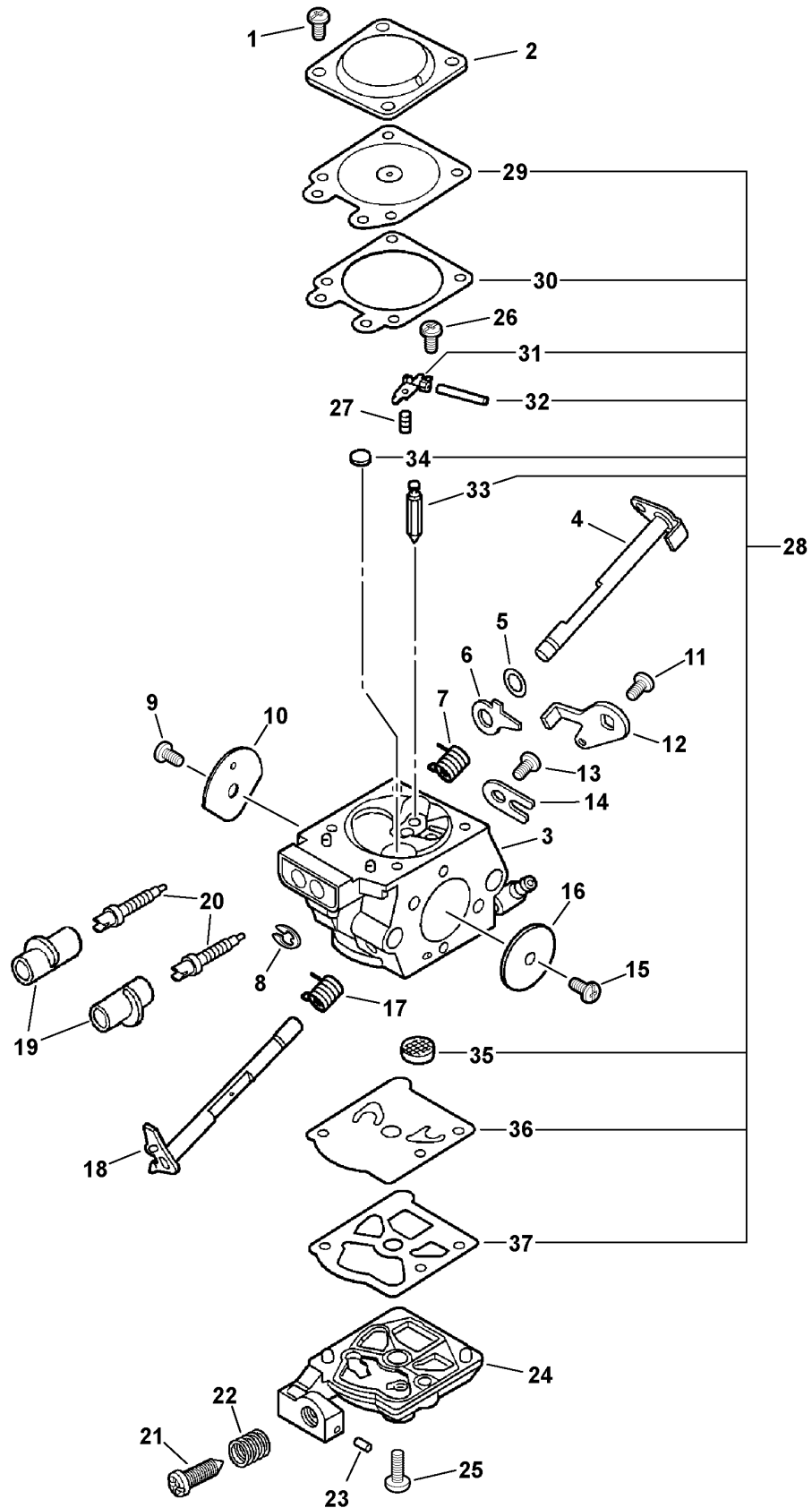

WT908 0000 000

ITEM	PART NUMBER	QTY	DESCRIPTION	REMARKS
	A021001620	1	CARBURETOR -- WT-908	
1	12313002960	4	SCREW, DIAPHRAGM COVER	
2	12314203930	1	COVER, METERING DIAPHRAGM	
3	-----	1	BODY, CARBURETOR <sup>1</sup>	
4	12313135430	1	SHAFT, CHOKE	
5	12314926030	1	WASHER	
6	P003001510	1	LEVER, FAST IDLE <sup>1</sup>	
7	P003000140	1	SPRING	
8	12312715030	1	CIRCLIP	
9	12311403930	1	SCREW, CHOKE VALVE	
10	12313237330	1	VALVE, CHOKE	
11	12311403930	1	SCREW, THROTTLE LEVER	
12	P003001520	1	LEVER, THROTTLE	
13	12313002960	1	SCREW, CLIP	
14	12312703930	1	CLIP, THROTTLE SHAFT	
15	12311403930	1	SCREW, THROTTLE VALVE	
16	12311610530	1	VALVE, THROTTLE	
17	12311337530	1	SPRING, THROTTLE RETURN	
18	P003001800	1	SHAFT, THROTTLE	
19	P003000010	2	CAP, MIXTURE LIMITER	
20	12311802261	2	NEEDLE, MIXTURE ADJUSTMENT	
21	12313404260	1	SCREW, IDLE ADJUST	
22	12313304260	1	SPRING, IDLE ADJUST	
23	12317815030	1	PLUG, FRICTION	
24	12312438330	1	COVER, FUEL PUMP	
25	12311003930	1	SCREW, PUMP COVER	
26	12313903930	1	SCREW, METERING LEVER PIN	
27	12312239330	1	SPRING, METERING LEVER	
28	P003002190	1	REPAIR KIT	INCLUDES ITEM 29-37
29	-----	1	DIAPHRAGM, METERING	
30	-----	1	GASKET, METERING DIAPHRAGM	
31	-----	1	LEVER, METERING	
32	-----	1	PIN, METERING LEVER	
33	-----	1	VALVE, INLET NEEDLE	
34	-----	1	PLUG, WELCH	
35	-----	1	SCREEN, INLET	
36	-----	1	DIAPHRAGM, FUEL PUMP	
37	-----	1	GASKET, FUEL PUMP	

**Footnotes**

1: NOT AVAILABLE SEPARATELY

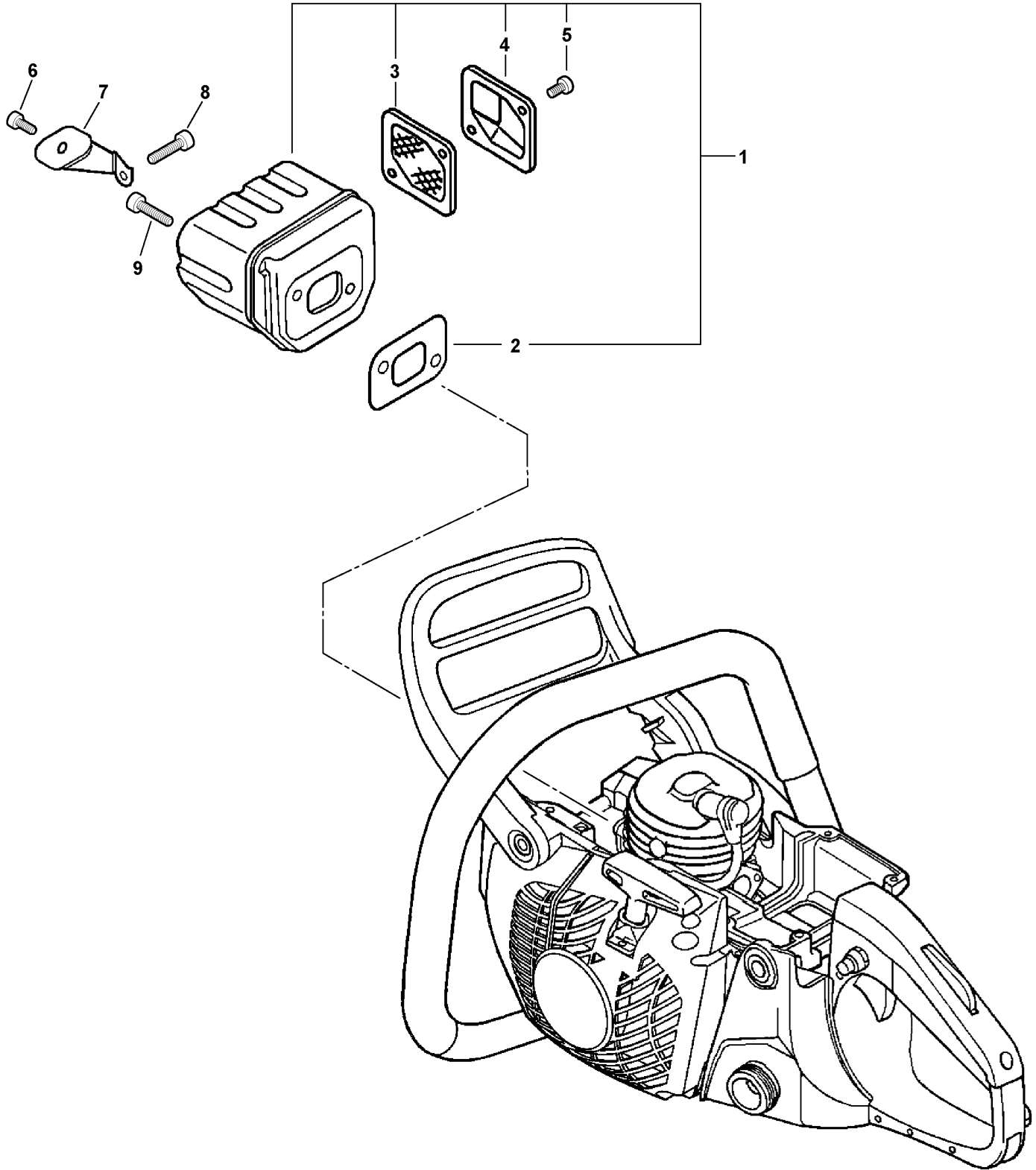

011 0008 000



ITEM	PART NUMBER	QTY	DESCRIPTION	REMARKS
1	P021014240	1	MUFFLER ASY	INCLUDES ITEMS 2-5
2	14551035431	1	GASKET, EXHAUST	
3	14588439330	1	SCREEN	
4	A303000120	1	GUIDE, EXHAUST	
5	90025004008	2	SCREW 4X8	
6	9110006008	1	SCREW	
7	A319000080	1	BRACKET, MUFFLER	
8	90010506014	1	SCREW 6X14	
9	90010505014	2	SCREW 5X14	

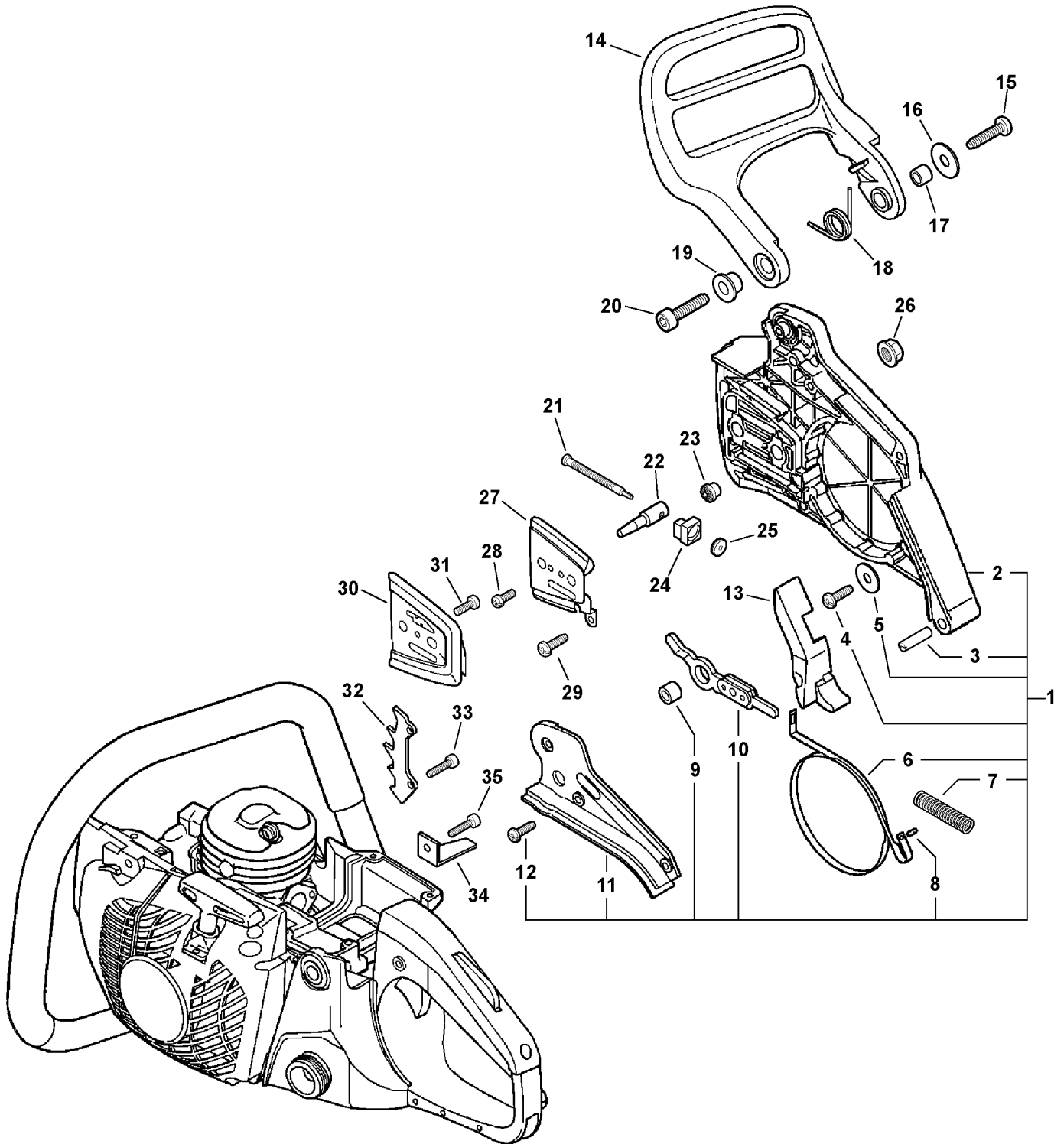

013 0010 000

ITEM	PART NUMBER	QTY	DESCRIPTION	REMARKS
1	C032000321	1	CHAIN BRAKE ASY - ORANGE	INCLUDES ITEMS 2-12
2	C300000351	1	GUARD, SPROCKET	
3	90034260025	1	SPRING PIN	
4	90025304016	1	SCREW 4X16	
5	35124906960	1	WASHER	
6	C328000110	1	BAND, BRAKE	
7	V450000070	1	SPRING	
8	90033030120	1	PIN	
9	43311635430	1	SPACER	
10	C334000090	1	CONNECTOR, BRAKE	
11	C345000241	1	COVER, BRAKE	
12	V202000060	3	TAPPING SCREW 4X12	
13	C302000000	1	COVER	
14	C320000141	1	LEVER, BRAKE	
15	V202000120	1	SCREW 4	
16	17721403930	1	WASHER	
17	43311635430	1	SPACER	
18	V452000250	1	SPRING	
19	V356000300	1	COLLAR	
20	90010505030	1	SCREW 5X30	
21	V203000110	1	BOLT	
22	C309000030	1	TENSIONER, CHAIN	
23	V651000001	1	GEAR, BEVEL	
24	V355000270	1	COLLAR	
25	V651000011	1	GEAR, BEVEL	
26	43301912330	2	FLANGE NUT	
27	C305000001	1	PLATE, SPROCKET GUARD	
28	90022003006	1	SCREW 3X6	
29	V202000060	1	TAPPING SCREW 4X12	
30	43301335432	1	PLATE, GUIDE	
31	90022004006	1	SCREW 4X6	
32	C304000030	1	BUMPER, SPIKED	
33	90010505012	2	SCREW 5X12	
34	C310000000	1	CATCHER, CHAIN	
35	90016205014	1	SCREW 5X16	

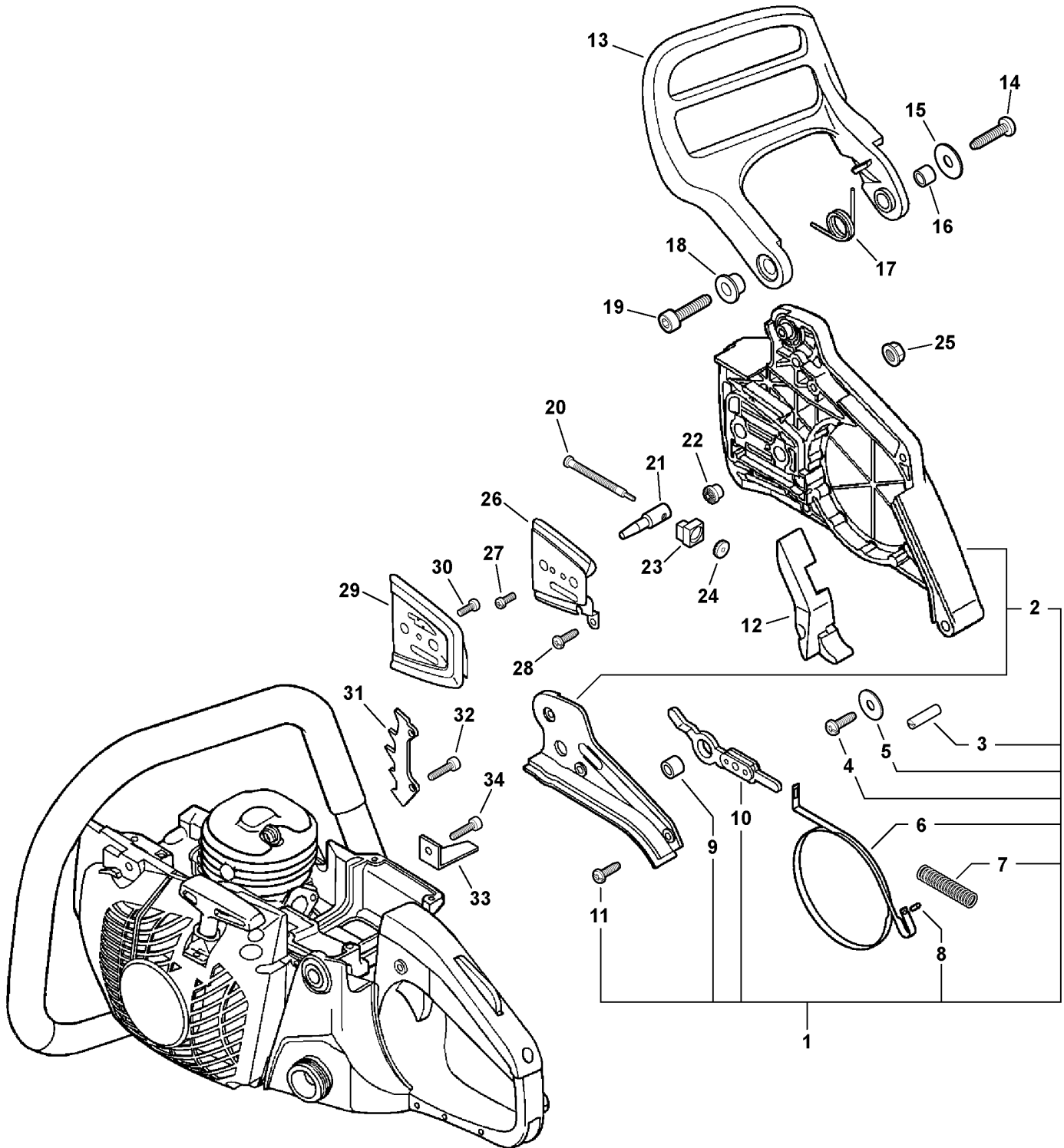

013 0010 00B

ITEM	PART NUMBER	QTY	DESCRIPTION	REMARKS
1	C032000321	1	CHAIN BRAKE ASY - ORANGE	INCLUDES ITEMS 2-11
2	P021015240	1	SPROCKET GUARD KIT	
3	90034260025	1	SPRING PIN	
4	90025304016	1	SCREW 4X16	
5	35124906960	1	WASHER	
6	C328000110	1	BAND, BRAKE	
7	V450000070	1	SPRING	
8	90033030120	1	PIN	
9	43311635430	1	SPACER	
10	C334000090	1	CONNECTOR, BRAKE	
11	V202000060	3	TAPPING SCREW 4X12	
12	C302000000	1	COVER	
13	C320000141	1	LEVER, BRAKE	
14	V202000120	1	SCREW 4	
15	17721403930	1	WASHER	
16	43311635430	1	SPACER	
17	V452000250	1	SPRING	
18	V356000300	1	COLLAR	
19	90010505016	1	SCREW 5X16	
20	V203000110	1	BOLT	
21	C309000030	1	TENSIONER, CHAIN	
22	V651000001	1	GEAR, BEVEL	
23	V355000270	1	COLLAR	
24	V651000011	1	GEAR, BEVEL	
25	43301912330	2	FLANGE NUT	
26	C305000001	1	PLATE, SPROCKET GUARD	
27	90022003006	1	SCREW 3X6	
28	V202000060	1	TAPPING SCREW 4X12	
29	43301335432	1	PLATE, GUIDE	
30	90022004006	1	SCREW 4X6	
31	C304000030	1	BUMPER, SPIKED	
32	90010505012	2	SCREW 5X12	
33	C310000000	1	CATCHER, CHAIN	
34	90016205014	1	SCREW 5X16	

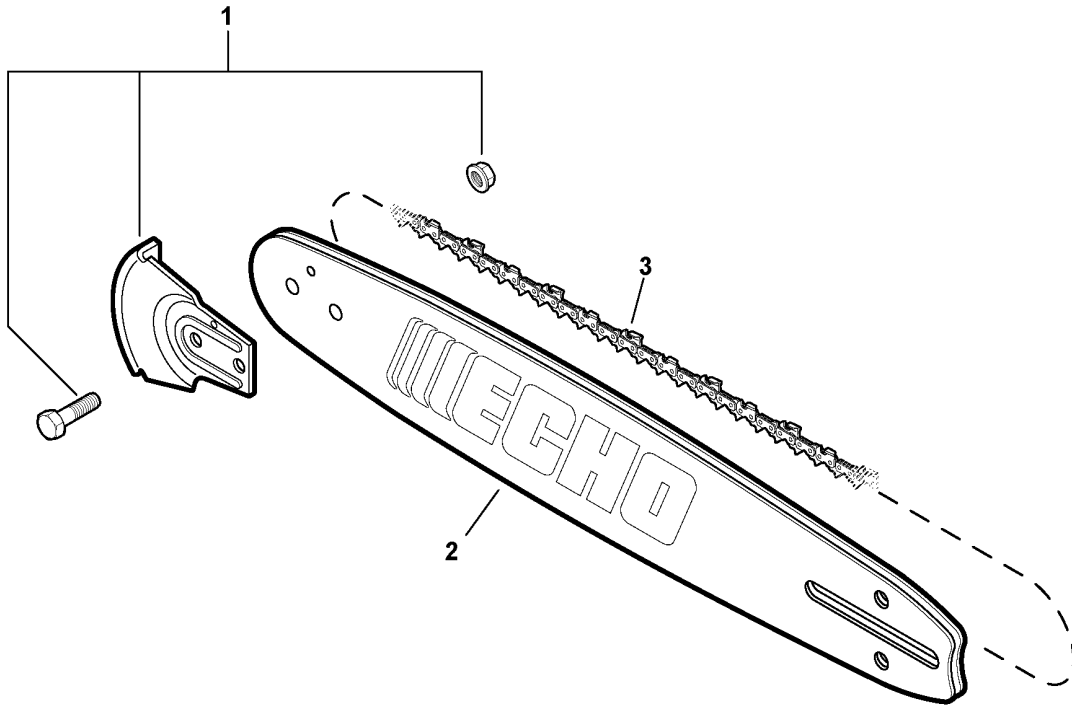

016 0009 000

ITEM	PART NUMBER	QTY	DESCRIPTION	REMARKS
1	2893201	1	KICK GUARD KIT	
2	16F0MD3366	1	GUIDE BAR - 16" -- MicroLite Pro	GAUGE: .050"
2	18F0MD3372	1	GUIDE BAR - 18" -- MicroLite Pro	GAUGE: .050"
2	20F0AD3378	1	GUIDE BAR - 20" -- ProAm Double Guard	GAUGE: .050"
3	95VP66G	1	SAWING CHAIN - 16" -- Micro-Lite	GAUGE: .050" / PITCH: .325"
3	95VP72G	1	SAWING CHAIN - 18" -- Micro-Lite	GAUGE: .050" / PITCH: .325"
3	33SL78G	1	SAWING CHAIN - 20" -- Pro Guard	GAUGE: .050" / PITCH: .325"

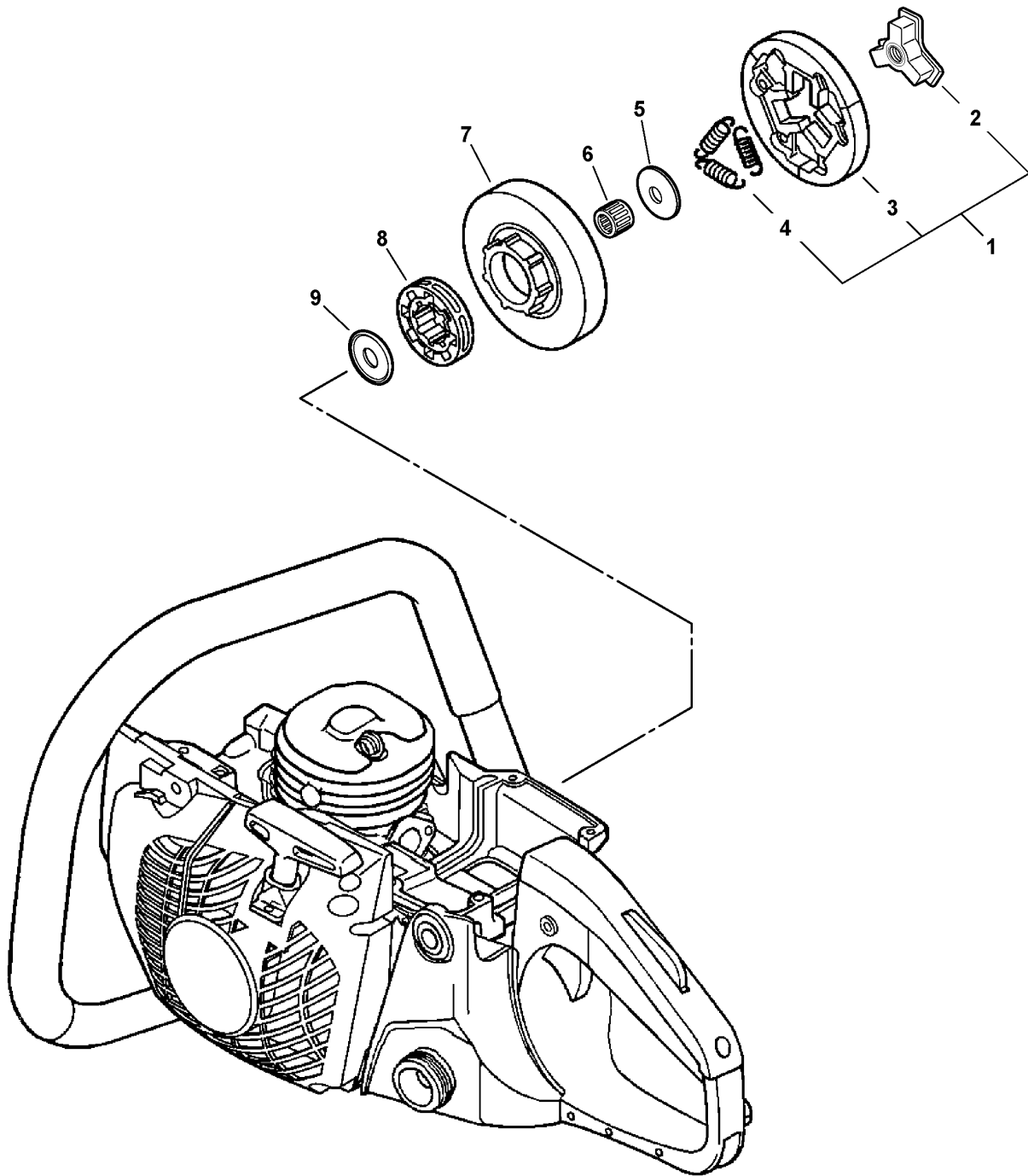

014 0007 000



ITEM	PART NUMBER	QTY	DESCRIPTION	REMARKS
1	A056000111	1	CLUTCH ASY	INCLUDES ITEMS 2-4
2	A552000090	1	HUB, CLUTCH	
3	P021007050	1	CLUTCH SHOE SET	
4	V451000500	3	SPRING, CLUTCH	
5	A551000060	1	PLATE, CLUTCH	
6	V557000010	1	BEARING, NEEDLE	
7	A556000021	1	DRUM, CLUTCH	
8	17511412530	1	SPROCKET, RIM	
9	A551000000	1	PLATE, CLUTCH	

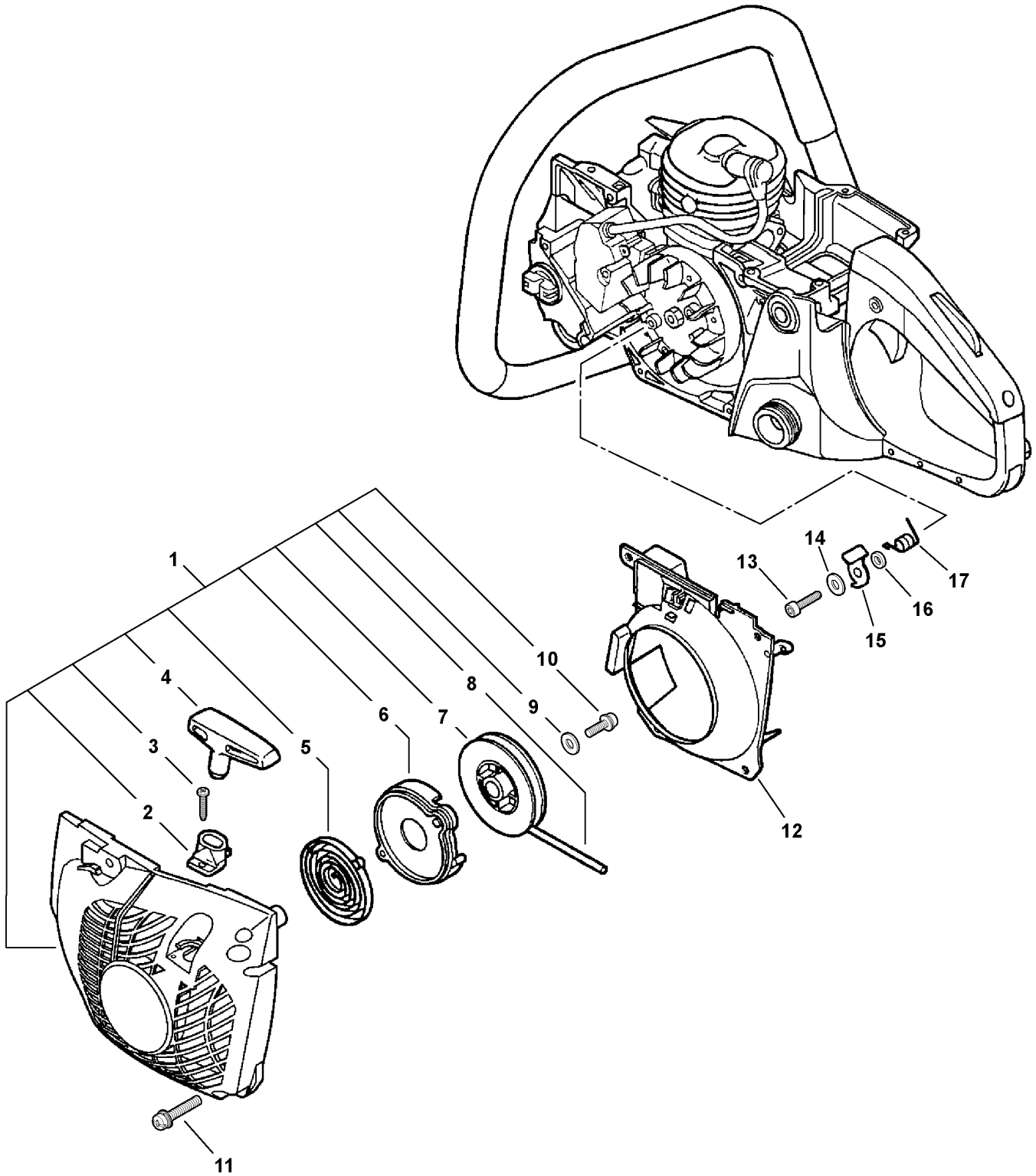

015 0007 000

ITEM	PART NUMBER	QTY	DESCRIPTION	REMARKS
1	P021013481	1	STARTER ASY	INCLUDES ITEMS 2-10
2	17722737930	1	GUIDE, ROPE	
3	90029603014	1	SCREW 3X14	
4	17722835430	1	GRIP, STARTER	
5	17722035430	1	SPRING, REWIND	
6	17722135430	1	PLATE, STARTER	
7	A506000100	1	DRUM, STARTER	
8	17722619830	1	ROPE, STARTER - 3.5X960mm	REPOWER BULK OPTION: 99944445000
9	17721402830	1	WASHER	
10	90023805018	4	SCREW 5X18	
11	90023805012	1	SCREW 5X12	
12	A172000062	1	COVER, FAN	
13	V203000090	2	SCREW 5X14	
14	90060300005	2	WASHER 5	
15	17721819830	2	PAWL, STARTER	
16	17724704630	2	SPACER	
17	17723435430	2	SPRING, RETURN	

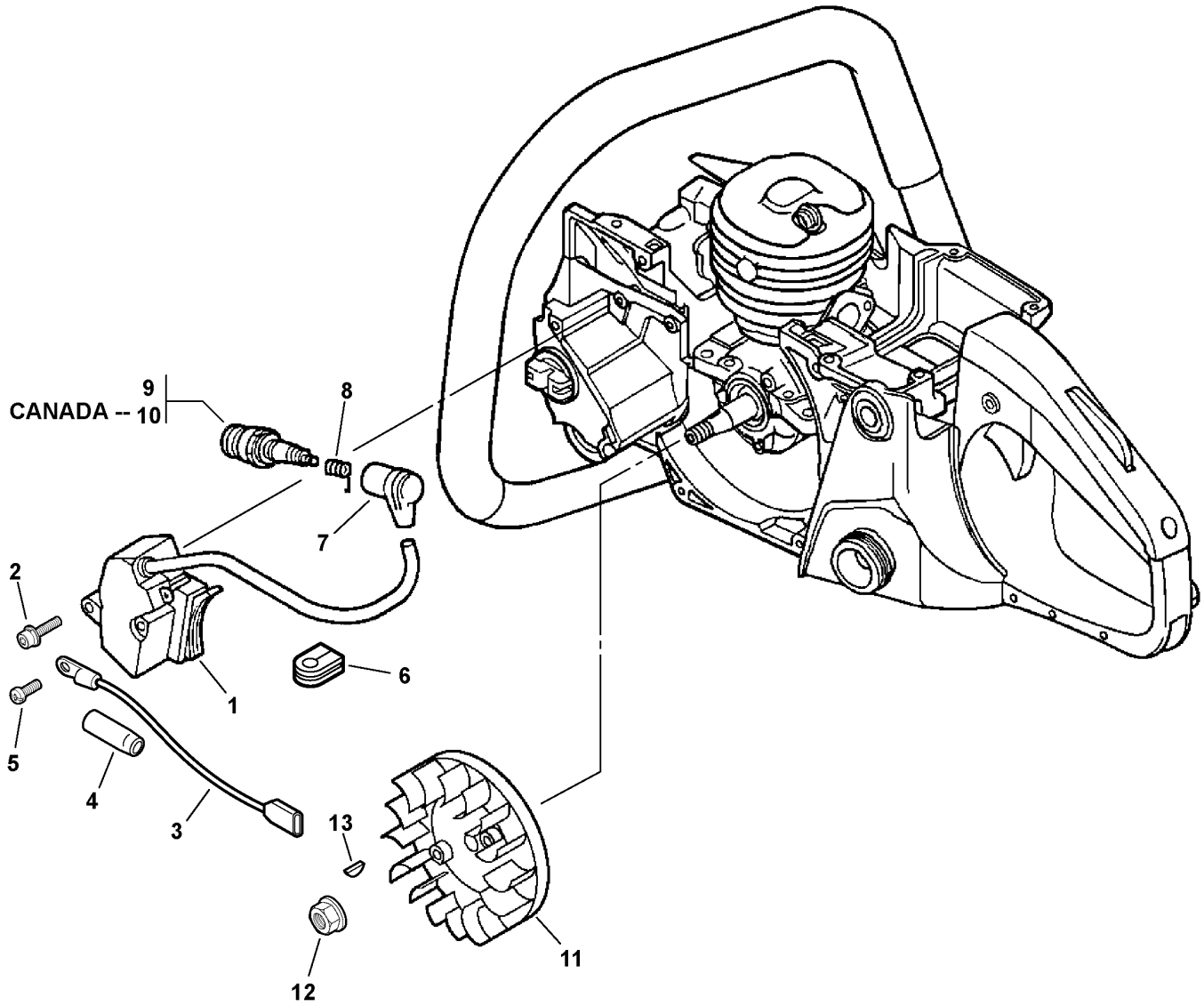

018 0008 000

ITEM	PART NUMBER	QTY	DESCRIPTION	REMARKS
1	A411000031	1	COIL, IGNITION	
2	90016204030	2	SCREW 4X30	
3	16201038332	1	LEAD, GROUND	
4	C483000000	1	BOOT, CONNECTOR	
5	90022004006	1	SCREW 4X6	
6	V135000010	1	GROMMET	
7	A427000013	1	CAP, SPARK PLUG	
8	A426000010	1	TERMINAL, SPARK PLUG CAP	
9	15901019830	1	SPARK PLUG -- BPM-8Y	
10	A425000000	1	SPARK PLUG -- BPMR-8Y	CANADA MODELS
11	A409000030	1	FLYWHEEL	
12	90051500008	1	NUT 8	
13	10014230830	1	WOODRUFF KEY	

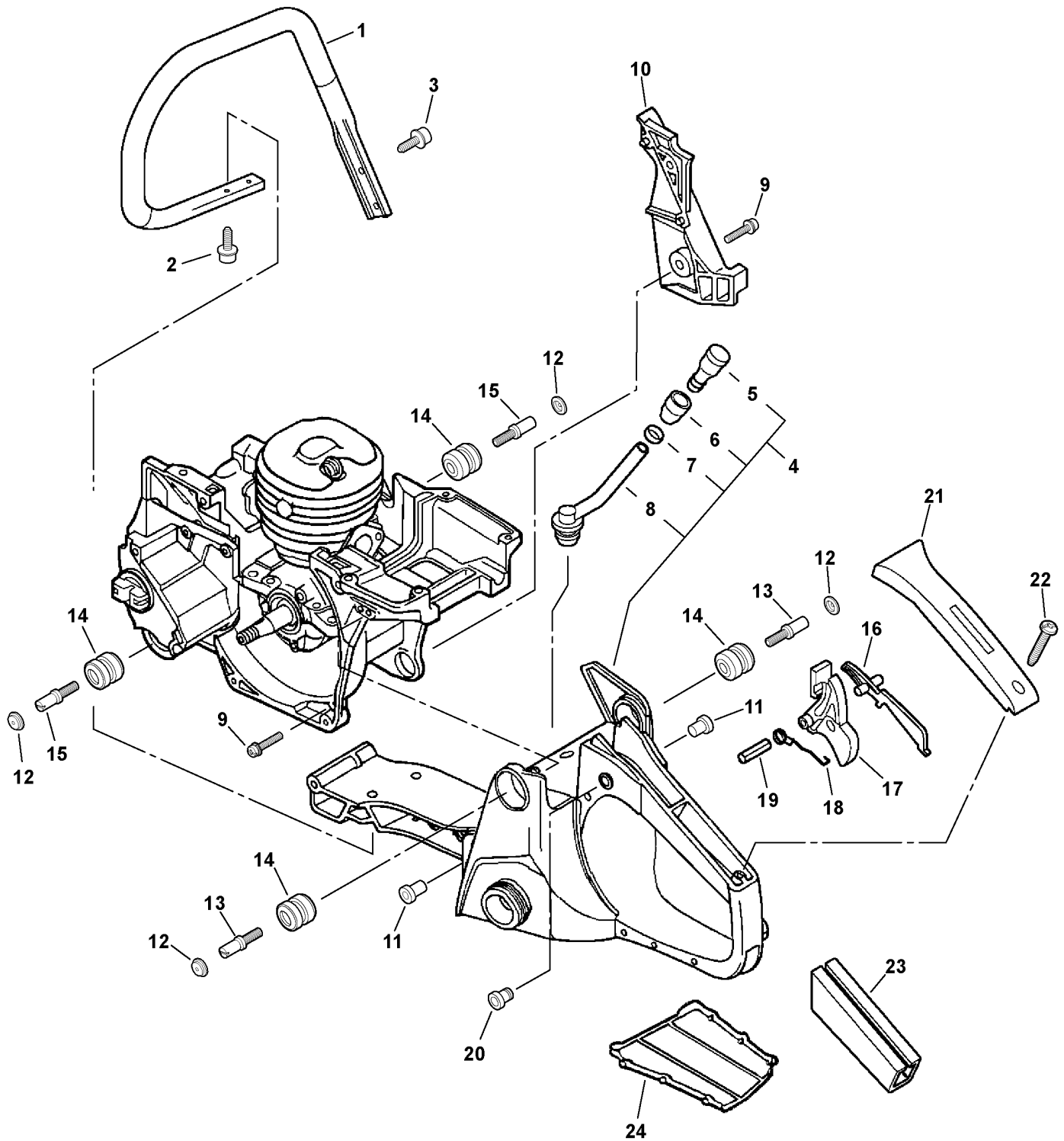

012 0008 ORG

ITEM	PART NUMBER	QTY	DESCRIPTION	REMARKS
1	C400000010	1	HANDLE, FRONT	
2	9114505016	2	SCREW 5X16	
3	9114505020	2	SCREW 5X20	
4	P021012561	1	REAR HANDLE ASY	INCLUDES ITEMS 5-8
5	A356000030	1	VENT ASY	
6	13132840630	1	COVER, VENT	
7	13201326630	1	CLIP	
8	13201239331	1	PIPE, VENT - GROMMET	
9	90023805016	3	SCREW 5X16	
10	C300000321	1	COVER	
11	10091038330	2	CUSHION	
12	10091838330	4	CAP, CUSHION	
13	10091532530	2	SCREW	
14	10092138330	4	CUSHION	
15	10091533930	2	SCREW	
16	C460000072	1	LOCKOUT, THROTTLE CONTROL	
17	C450000212	1	TRIGGER, THROTTLE	
18	V452000260	1	SPRING, THROTTLE RETURN	
19	90034540030	1	SPRING PIN 4X30	
20	V162000040	1	PLUG	
21	35115535430	1	COVER, HANDLE	
22	90025304014	1	SCREW 4X14	
23	35111119830	1	GRIP, HANDLE	
24	C418000040	1	SHIELD, SNOW	

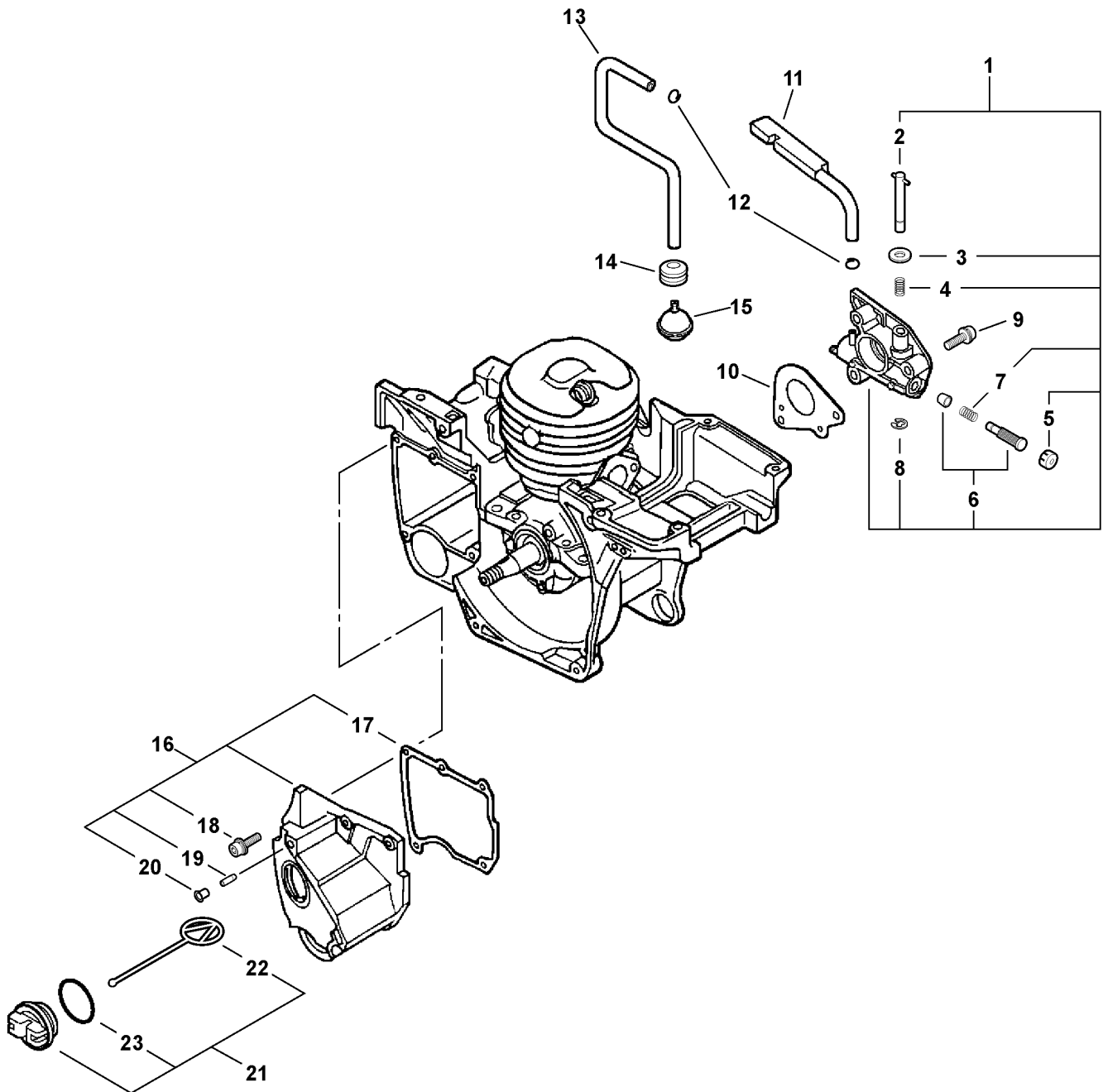

017 0006 ORG



ITEM	PART NUMBER	QTY	DESCRIPTION	REMARKS
1	43700238330	1	AUTO-OILER ASY	INCLUDES ITEMS 2-9
2	43701638330	1	NEEDLE, ADJUST	
3	43702937330	1	WASHER	
4	43701537330	1	SPRING	
5	43706238330	1	CAP, OIL PUMP	
6	43702437330	1	PLUNGER	
7	43701938330	1	SPRING	
8	12312715030	1	CIRCLIP	
9	90022304016	2	SCREW 4X16	
10	17531038330	1	PLATE, SEAL	
11	43722938331	1	PIPE, OIL OUTLET	
12	13201326630	2	CLIP	
13	43721038330	1	PIPE, OIL	
14	13211512330	1	GROMMET	
15	43620514730	1	FILTER, OIL	
16	P021012550	1	OIL TANK ASY	INCLUDES ITEMS 17-20
17	43601938330	1	GASKET, OIL TANK	
18	90016304016	3	SCREW 4X16	
19	43611413930	1	VALVE, CHECK	
20	43601838330	1	COLLAR	
21	P021007630	1	CAP ASY	INCLUDES ITEMS 22-23
22	A365000050	1	CONNECTOR, CAP	
23	90072502025	1	O-RING	

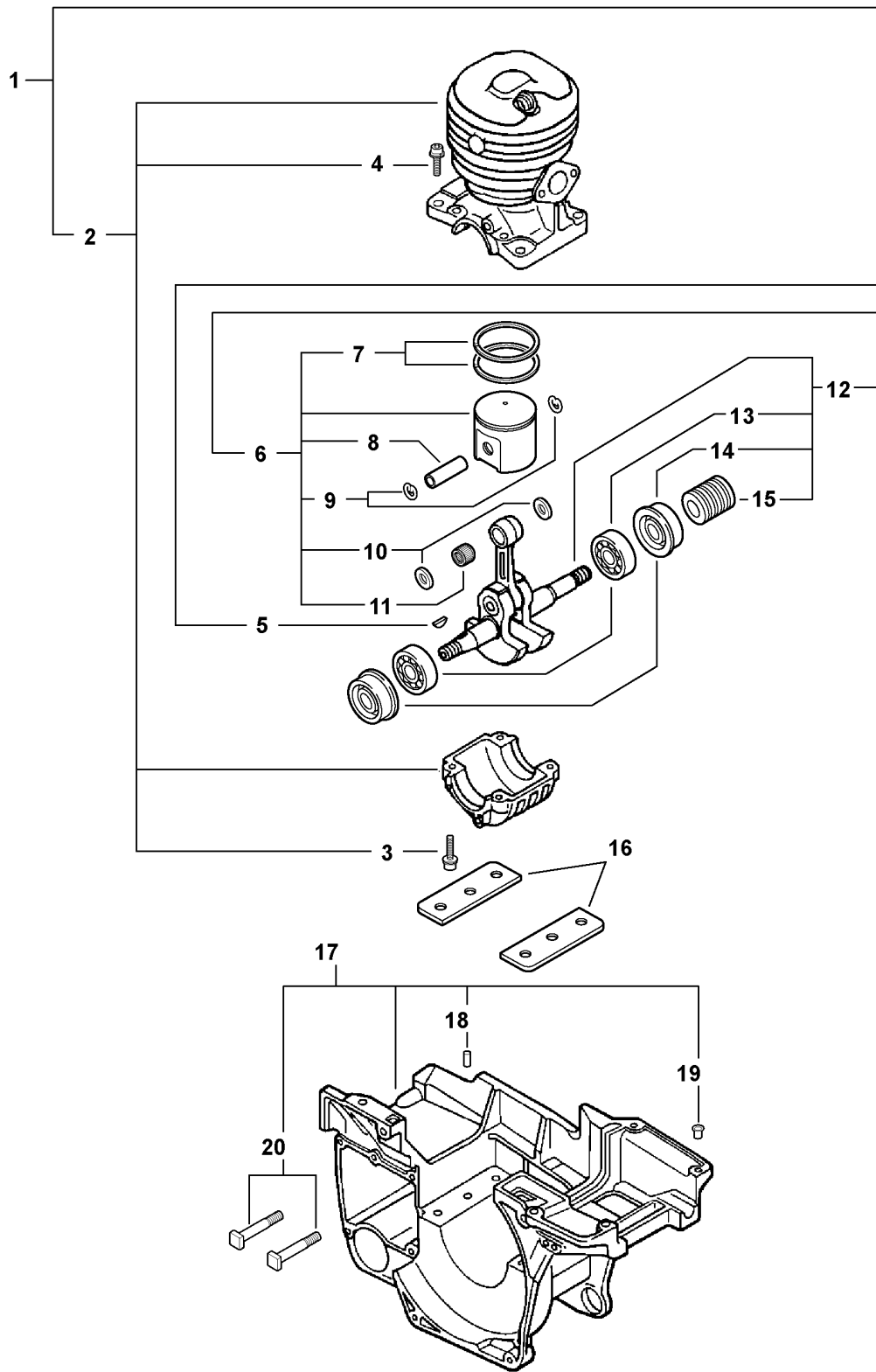

SB1080 0001 ORG

ITEM	PART NUMBER	QTY	DESCRIPTION	REMARKS
1	SB1080	1	SHORT BLOCK	INCLUDES ITEMS 2-15
2	P021006992	1	CRANKCASE SET	INCLUDES ITEMS 3-4
3	90010605020	4	SCREW 5X20	
4	V203000170	4	SCREW 5X22	
5	10014230830	1	WOODRUFF KEY	
6	P021006152	1	PISTON KIT	INCLUDES ITEMS 7-11
7	10001139731	2	RING, PISTON	
8	V609000000	1	PIN, PISTON	
9	10001532330	2	CIRCLIP, PISTON PIN	
10	V308000000	2	SPACER, PISTON PIN	
11	V556000000	1	BEARING, NEEDLE	
12	P021007140	1	CRANKSHAFT ASY	INCLUDES ITEMS 13-15
13	90081036202	2	BEARING, BALL - 6202	
14	V508000000	2	OIL SEAL	
15	V652000000	1	GEAR, WORM	
16	V150001740	2	EYE PLATE	
17	P021012470	1	ENGINE COVER ASY	INCLUDES ITEMS 18-20
18	10021503930	2	DOWEL PIN - 4x8mm	
19	43601838330	2	COLLAR	
20	43301119830	2	STUD, GUIDE BAR	



**CS-530**  
**WARNING!** Read and follow all safety precautions in the instruction manual. Failure to follow instructions could result in serious personal injury.



**TO AVOID KICKBACK**

1. Hold the chain saw firmly with both hands.
2. Don't let the nose of the guide bar contact any obstruction.
3. Tip contact may suddenly move the guide bar upward and backward, which may cause serious injury.

**REPLACEMENT BAR AND CHAIN**

GUIDE BAR*	CHAIN*
PART NO.	TYPE LINKS
16" 16FMD3366	ORE GON 95VP 66
18" 18FMD3372	ORE GON 95VP 72
20" 20FMD3378	ORE GON 33SL 78
*Or equivalent	

Note: There may be other replacement components for achieving kickback protection. For details, please refer to the bar and chain combination sheet shown in the instruction manual.



**STOP**

100 0079 US0

**CS-530 Chain Saw**

**Labels**

ITEM	PART NUMBER	QTY	DESCRIPTION	REMARKS
1	X503009050	1	LABEL - MODEL -- CS-530	
2	X502000340	1	LABEL - ECHO	
3	89019130131	1	LABEL - KICK BACK	
4	89015737330	1	LABEL - STOP	
5	X502000410	1	LABEL - ECHO	
6	X524002000	1	LABEL - BAR & CHAIN	

**SOCKET WRENCH W/SCREWDRIVER (Also Removes Spark Plugs)**

1 - 89541010630 -- 17X19mm

2 - X602000020 -- 17X19mm

3 - 89541039131 -- 10X19mm

4 - 89541006960 -- 13X19mm

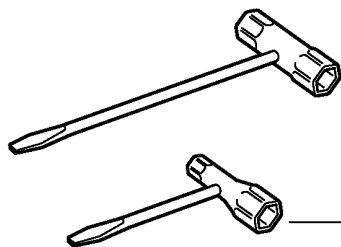

**SOCKET WRENCH**

5 - X602000031 -- 17X14.5mm

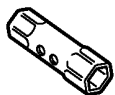

**LOCKING BAR**

6 - 89751801131 -- 5X120mm



**OPEN END WRENCH**

7 - 89511200330 -- 8X10mm

8 - 89512220960 -- 17X19mm

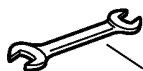

9 - 89501505260 -- 10mm



**HEX BAR**

10 - 89541220960 -- 10mm



**HEX KEY**

11 - 89561203430 -- 3mm



12 - 89561000130 -- 4mm



13 - 89561100330 -- 5mm



**TORX KEY**

14 - X605000060 -- T27



**SCREWDRIVER**

15 - 89581100130 -- 125mm SLOTTED

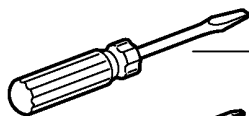

16 - 89581203930 -- 50mm PHILLIPS

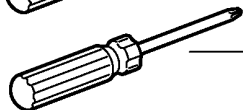

**CHUCK KEY**

17 - 89757005560

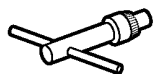

200 0002 000

ITEM	PART NUMBER	QTY	DESCRIPTION	REMARKS
1	89541010630	1	SOCKET WRENCH/SCREWDRIVER	17X19mm
2	X602000020	1	SOCKET WRENCH/SCREWDRIVER	17X19mm
3	89541039131	1	SOCKET WRENCH/SCREWDRIVER	10X19mm
4	89541006960	1	SOCKET WRENCH/SCREWDRIVER	13X19mm
5	X602000031	1	SOCKET WRENCH	17X14.5mm
6	89751801131	1	LOCKING BAR	5X120mm
7	89511200330	1	OPEN END WRENCH	8X10mm
8	89512220960	1	OPEN END WRENCH	17X19mm
9	89501505260	1	OPEN END WRENCH	10mm
10	89541220960	1	HEX BAR	10mm
11	89561203430	1	HEX KEY	3mm
12	89561000130	1	HEX KEY	4mm
13	89561100330	1	HEX KEY	5mm
14	X605000060	1	TORX KEY	T27
15	89581100130	1	SCREWDRIVER	SLOTTED HEAD
16	89581203930	1	SCREWDRIVER	PHILLIPS HEAD
17	89757005560	1	CHUCK KEY	



# Part Number Index

Click The Page Number After Any Part Number To View The Diagram Containing That Part.

Part Number	Page	Part Number	Page	Part Number	Page	Part Number	Page
.....	5, 7	35115535430	.....23	A241000101	.....5	V651000001	.....11, 13
10001139731	.....27	35124906960	.....11, 13	A303000120	.....9	V651000011	.....11, 13
10001532330	.....27	43301119830	.....27	A319000080	.....9	V652000000	.....27
10014230830	.....21, 27	43301335432	.....11, 13	A356000030	.....23	X502000340	.....29
10021503930	.....27	43301912330	.....11, 13	A365000050	.....5, 25	X502000410	.....29
10091038330	.....23	43311635430	.....11, 13	A409000030	.....21	X503009050	.....29
10091532530	.....23	43601838330	.....25, 27	A411000031	.....21	X524002000	.....29
10091533930	.....23	43601938330	.....25	A425000000	.....21	X602000020	.....31
10091838330	.....23	43611413930	.....25	A426000010	.....21	X602000031	.....31
10092138330	.....23	43620514730	.....25	A427000013	.....21	X605000060	.....31
10152035430	.....5	43700238330	.....25	A506000100	.....19		
12311003930	.....7	43701537330	.....25	A551000000	.....17		
12311337530	.....7	43701638330	.....25	A551000060	.....17		
12311403930	.....7	43701938330	.....25	A552000090	.....17		
12311610530	.....7	43702437330	.....25	A556000021	.....17		
12311802261	.....7	43702937330	.....25	C032000321	.....11, 13		
12312239330	.....7	43706238330	.....25	C300000321	.....23		
12312438330	.....7	43721038330	.....25	C300000351	.....11		
12312703930	.....7	43722938331	.....25	C302000000	.....11, 13		
12312715030	.....7, 25	89015737330	.....29	C304000030	.....11, 13		
12313002960	.....7	89019130131	.....29	C305000001	.....11, 13		
12313135430	.....7	89501505260	.....31	C309000030	.....11, 13		
12313237330	.....7	89511200330	.....31	C310000000	.....11, 13		
12313304260	.....7	89512220960	.....31	C320000141	.....11, 13		
12313404260	.....7	89541006960	.....31	C328000110	.....11, 13		
12313903930	.....7	89541010630	.....31	C334000090	.....11, 13		
12314203930	.....7	89541039131	.....31	C345000241	.....11		
12314926030	.....7	89541220960	.....31	C400000010	.....23		
12317815030	.....7	89561000130	.....31	C418000040	.....23		
13000038331	.....5	89561100330	.....31	C450000212	.....23		
13001038330	.....5	89561203430	.....31	C454000150	.....5		
13001639930	.....5	89581100130	.....31	C460000072	.....23		
13002033330	.....5	89581203930	.....31	C483000000	.....21		
13011038330	.....5	89751801131	.....31	P003000010	.....7		
13031038331	.....5	89757005560	.....31	P003000140	.....7		
13033832430	.....5	90010505012	.....11, 13	P003001510	.....7		
13040538332	.....5	90010505014	.....9	P003001520	.....7		
13043038330	.....5	90010505016	.....11, 13	P003001800	.....7		
13051039932	.....5	90010506014	.....9	P003002190	.....7		
13120519830	.....5	90010605020	.....27	P021006152	.....27		
13132840630	.....23	90016204030	.....21	P021006992	.....27		
13201038331	.....5	90016205014	.....11, 13	P021007050	.....17		
13201239331	.....23	90016205050	.....5	P021007140	.....27		
13201326630	.....5, 23, 25	90016304016	.....25	P021007153	.....5		
13211504920	.....5	90022003006	.....11, 13	P021007630	.....25		
13211512330	.....25	90022004006	.....11, 13, 21	P021010600	.....5		
14551035431	.....9	90022304016	.....25	P021012470	.....27		
14588439330	.....9	90023805012	.....5, 19	P021012550	.....25		
15901019830	.....21	90023805016	.....23	P021012561	.....23		
16201038332	.....21	90023805018	.....19	P021013481	.....19		
16340038330	.....5	90025004008	.....9	P021014240	.....9		
16341338930	.....5	90025304014	.....23	P021015240	.....13		
16381038933	.....5	90025304016	.....11, 13	SB1080	.....27		
16389038330	.....5	90029603014	.....19	V135000010	.....21		
16F0MD3366	.....15	90033030120	.....11, 13	V150001740	.....27		
17511412530	.....17	90034260025	.....11, 13	V162000040	.....23		
17531038330	.....25	90034540030	.....23	V202000060	.....11, 13		
17721402830	.....19	90051500008	.....21	V202000120	.....11, 13		
17721403930	.....11, 13	90060300005	.....19	V203000090	.....19		
17721819830	.....19	90072000022	.....5	V203000110	.....11, 13		
17722035430	.....19	90072502025	.....25	V203000170	.....27		
17722135430	.....19	90081036202	.....27	V308000000	.....27		
17722619830	.....19	91100060008	.....9	V355000270	.....11, 13		
17722737930	.....19	9114505016	.....23	V356000300	.....11, 13		
17722835430	.....19	9114505020	.....23	V420001130	.....5		
17723435430	.....19	95VP66G	.....15	V450000070	.....11, 13		
17724704630	.....19	95VP72G	.....15	V451000500	.....17		
17881014534	.....5	A021001620	.....7	V452000250	.....11, 13		
18F0MD3372	.....15	A056000111	.....17	V452000260	.....23		
20F0AD3378	.....15	A160000950	.....5	V508000000	.....27		
2893201	.....15	A172000062	.....19	V556000000	.....27		
33SL78G	.....15	A204000004	.....5	V557000010	.....17		
35111119830	.....23	A2350000020	.....5	V609000000	.....27		





# Part Description Index

Click The Page Number After Any Part Description To View The Diagram Containing That Part.

## A

ADAPTER, INTAKE.....5  
 AIR CLEANER COVER KIT.....5  
 AUTO-OILER ASY.....25

## B

BAND, BRAKE.....11, 13  
 BEARING, BALL - 6202.....27  
 BEARING, NEEDLE.....17, 27  
 BODY, CARBURETOR.....7  
 BOLT.....11, 13  
 BOOT, CONNECTOR.....21  
 BRACKET, MUFFLER.....9  
 BRACKET, SWITCH.....5  
 BUMPER, SPIKED.....11, 13

## C

CAP ASY.....5, 25  
 CAP, AIR FILTER.....5  
 CAP, CUSHION.....23  
 CAP, MIXTURE LIMITER.....7  
 CAP, OIL PUMP.....25  
 CAP, SPARK PLUG.....21  
 CARBURETOR.....5  
 CARBURETOR -- WT-908.....7  
 CATCHER, CHAIN.....11, 13  
 CHAIN BRAKE ASY - ORANGE.....11, 13  
 CHUCK KEY.....31  
 CIRCLIP.....7, 25  
 CIRCLIP, PISTON PIN.....27  
 CLIP.....5, 23, 25  
 CLIP, THROTTLE SHAFT.....7  
 CLUTCH ASY.....17  
 CLUTCH SHOE SET.....17  
 COIL, IGNITION.....21  
 COLLAR.....11, 13, 25, 27  
 CONNECTOR, CAP.....25  
 CONNECTOR, BRAKE.....11, 13  
 CONNECTOR, FUEL TANK CAP.....5  
 COVER.....11, 13, 23  
 COVER, BRAKE.....11  
 COVER, ENGINE.....5  
 COVER, FAN.....19  
 COVER, FUEL PUMP.....7  
 COVER, HANDLE.....23  
 COVER, METERING DIAPHRAGM.....7  
 COVER, VENT.....23  
 CRANKCASE SET.....27  
 CRANKSHAFT ASY.....27  
 CUSHION.....5, 23

## D

DEFLECTOR, HEAT.....5  
 DIAPHRAGM, FUEL PUMP.....7  
 DIAPHRAGM, METERING.....7  
 DOWEL PIN - 4x8mm.....27  
 DRUM, CLUTCH.....17  
 DRUM, STARTER.....19

## E

ELBOW, CARBURETOR.....5  
 ENGINE COVER ASY.....27  
 EYE PLATE.....27

## F

FILTER, AIR.....5  
 FILTER, FUEL.....5  
 FILTER, OIL.....25  
 FLANGE NUT.....11, 13  
 FLYWHEEL.....21

## G

GASKET, EXHAUST.....9  
 GASKET, FUEL PUMP.....7  
 GASKET, INTAKE.....5  
 GASKET, METERING DIAPHRAGM.....7  
 GASKET, OIL TANK.....25  
 GEAR, BEVEL.....11, 13  
 GEAR, WORM.....27  
 GRIP, HANDLE.....23  
 GRIP, STARTER.....19  
 GROMMET.....5, 21, 25  
 PLATE, SPROCKET.....11  
 GUIDE BAR - 16" -- MicroLite Pro.....15  
 GUIDE BAR - 18" -- MicroLite Pro.....15  
 GUIDE BAR - 20" -- ProAm Double Guard.....15  
 GUIDE, EXHAUST.....9  
 GUIDE, ROPE.....19

## H

HANDLE, FRONT.....23  
 HEX BAR.....31  
 HEX KEY.....31  
 HUB, CLUTCH.....17

## I

INTAKE INSULATOR KIT.....5

## K

KICK GUARD KIT.....15  
 KNOB, AIR CLEANER LID.....5

## L

LABEL - KICK BACK.....29  
 LABEL - BAR & CHAIN.....29  
 LABEL - ECHO.....29  
 LABEL - MODEL -- CS-530.....29  
 LABEL - STOP.....29  
 LEAD, GROUND.....21  
 LEVER, BRAKE.....11, 13  
 LEVER, FAST IDLE.....7  
 LEVER, METERING.....7  
 LEVER, THROTTLE.....7  
 LOCKING BAR.....31  
 LOCKOUT, THROTTLE CONTROL.....23

## M

MUFFLER ASY.....9

## N

NEEDLE, ADJUST.....25  
 NEEDLE, MIXTURE ADJUSTMENT.....7  
 NUT.....5  
 NUT 8.....21

## O

OIL SEAL.....27  
 OIL TANK ASY.....25  
 OPEN END WRENCH.....31  
 O-RING.....25  
 O-RING 22.....5

## P

PAWL, STARTER.....19  
 PIN.....11, 13  
 PIN, METERING LEVER.....7  
 PIN, PISTON.....27  
 PIPE, FUEL - SPIRAL.....5  
 PIPE, IMPULSE.....5  
 PIPE, OIL.....25  
 PIPE, OIL OUTLET.....25  
 PIPE, VENT - GROMMET.....23  
 PISTON KIT.....27  
 PLATE, CLUTCH.....17  
 PLATE, GUIDE.....11, 13  
 PLATE, SEAL.....25  
 PLATE, SPROCKET GUARD.....11, 13  
 PLATE, STARTER.....19  
 PLUG.....5, 23  
 PLUG, FRICTION.....7  
 PLUG, WELCH.....7  
 PLUNGER.....25

## R

REAR HANDLE ASY.....23  
 REPAIR KIT.....7  
 RING, PISTON.....27  
 ROD, CHOKE.....5  
 ROD, THROTTLE.....5  
 ROPE, STARTER - 3.5X960mm.....19

## S

SAWING CHAIN - 16" -- Micro-Lite.....15  
 SAWING CHAIN - 18" -- Micro-Lite.....15  
 SAWING CHAIN - 20" -- Pro Guard.....15  
 SCREEN.....9  
 SCREEN, INLET.....7  
 SCREW.....9, 23  
 SCREW 3X14.....19  
 SCREW 3X6.....11, 13  
 SCREW 4.....11, 13  
 SCREW 4X14.....23  
 SCREW 4X16.....11, 13, 25  
 SCREW 4X30.....21  
 SCREW 4X6.....11, 13, 21  
 SCREW 4X8.....9  
 SCREW 5.....5  
 SCREW 5X12.....5, 11, 13, 19  
 SCREW 5X14.....9, 19  
 SCREW 5X16.....11, 13, 23  
 SCREW 5X18.....19  
 SCREW 5X20.....23, 27  
 SCREW 5X22.....27  
 SCREW 5X50.....5  
 SCREW 6X14.....9  
 SCREW, CHOKE VALVE.....7  
 SCREW, CLIP.....7  
 SCREW, DIAPHRAGM COVER.....7



# Part Description Index (continued)

---

SCREW, IDLE ADJUST.....7  
 SCREW, METERING LEVER PIN.....7  
 SCREW, PUMP COVER.....7  
 SCREW, THROTTLE LEVER.....7  
 SCREW, THROTTLE VALVE.....7  
 SCREWDRIVER.....31  
 SHAFT, CHOKE.....7  
 SHAFT, THROTTLE.....7  
 SHIELD, SNOW.....23  
 SHORT BLOCK.....27  
 SOCKET WRENCH.....31  
 SOCKET WRENCH/SCREWDRIVER.....31  
 SPACER.....11, 13, 19  
 SPACER, PISTON PIN.....27  
 SPARK PLUG -- BPM-8Y.....21  
 SPARK PLUG -- BPMR-8Y.....21  
 SPRING.....7, 11, 13, 25  
 SPRING PIN.....11, 13  
 SPRING PIN 4X30.....23  
 SPRING, CLUTCH.....17  
 SPRING, IDLE ADJUST.....7  
 SPRING, METERING LEVER.....7  
 SPRING, RETURN.....19  
 SPRING, REWIND.....19  
 SPRING, THROTTLE RETURN.....7, 23  
 SPROCKET GUARD KIT.....13  
 SPROCKET, RIM.....17  
 STARTER ASY.....19  
 STUD, GUIDE BAR.....27  
 SWITCH, IGNITION.....5

## T

TAPPING SCREW 4X12.....11, 13  
 TENSIONER, CHAIN.....11, 13  
 TERMINAL, SPARK PLUG CAP.....21  
 TERMINAL, SWITCH.....5  
 TORX KEY.....31  
 TRIGGER, THROTTLE.....23

## V

VALVE, CHECK.....25  
 VALVE, CHOKE.....7  
 VALVE, INLET NEEDLE.....7  
 VALVE, THROTTLE.....7  
 VENT ASY.....23

## W

WASHER.....7, 11, 13, 19, 25  
 WASHER 5.....19  
 WOODRUFF KEY.....21, 27

## **NOTES**



ECHO, INCORPORATED  
400 Oakwood Road  
Lake Zurich, IL 60047 USA

[WWW.ECHO-USA.COM](http://WWW.ECHO-USA.COM)

---