

# Homelite®

## PARTS LIST

### Zip Start™ Trimmers/Brushcutters

<b>EasyTrim™</b>	UT20693		
<b>d825cdp</b>	UT20705		
<b>Trim N' Edge™</b>	UT20694, UT20707,	UT20697, UT20728	UT20698, UT20702,
<b>d725cde</b>	UT20695,	UT20713	
<b>Easy Reach™</b>	UT20699, UT20737,	UT20703, UT20738	UT20704, UT20730,
<b>d825sd</b>	UT20700,	UT20701,	UT20709, UT20729
<b>Expand-it™</b>	UT20710, UT20735	UT20712,	
<b>d825ca</b>	UT20711,	UT20736	
<b>VersaTool™</b>	UT15151, UT20723	UT15154,	UT15157, UT20722,
<b>d825sb</b>	UT15152,	UT15160	
<b>ST2517CR</b>	UT20726R,	UT20823	
<b>ST2537S</b>	UT20734R,	UT20827	
<b>BC2500 MR</b>	UT15159R,	UT15204	

**PART NO. PS05001**

# IGNITION - ROTOR - STARTER

## Non-Clutch

EasyTrim™ ..... (UT20693)  
 d825cdp ..... (UT20705)  
 d825cde ..... (UT20695, UT20713)  
 d825sd ..... (UT20700, UT20701, UT20709, UT20729)

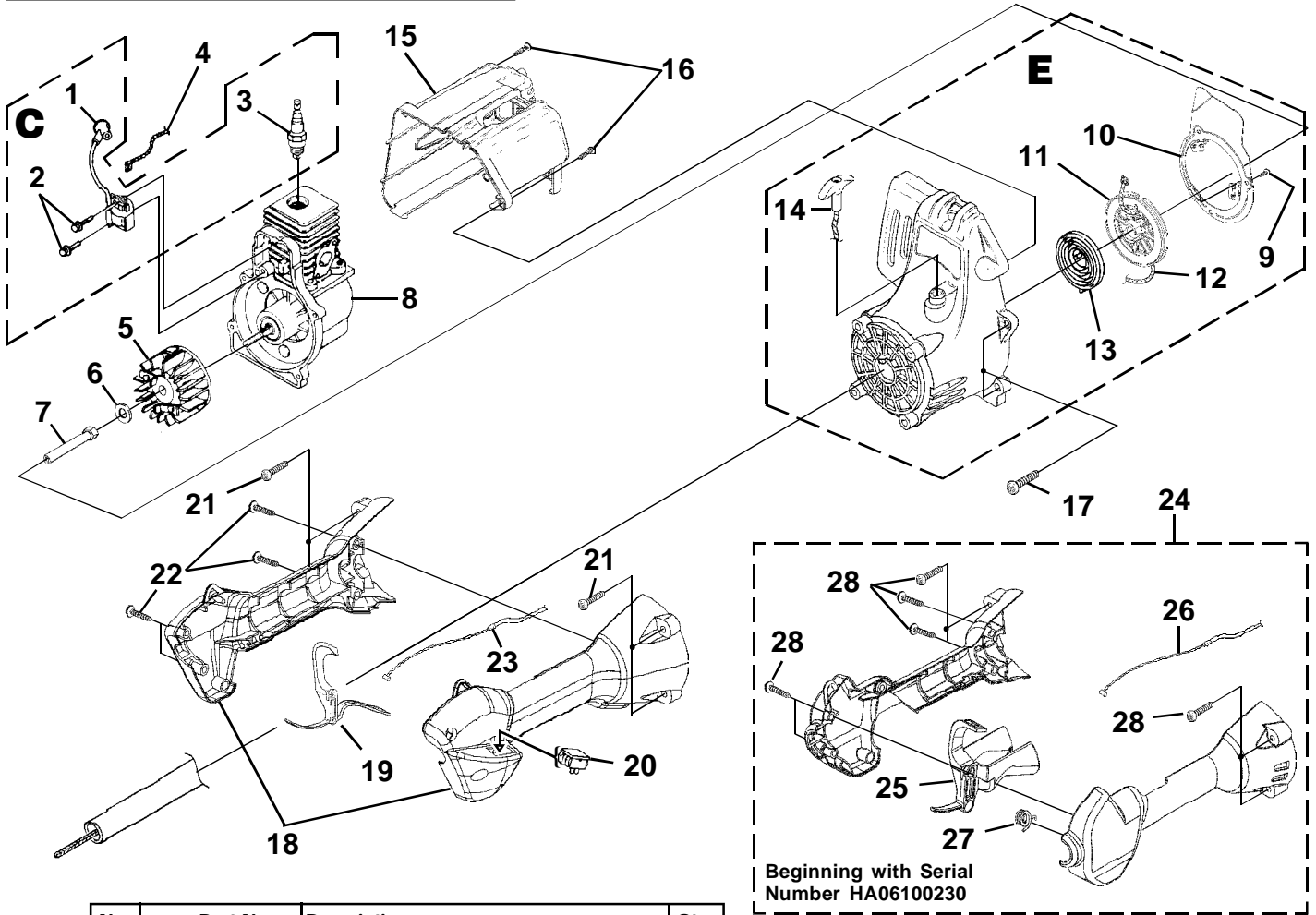

No.	Part No.	Description	Qty.
<b>C</b>	• A 07174	IGNITION KIT	1
1	UP 03868	TERMINAL & COVER	1
2	UP 03896	SCREW-Taptite (8-32 X 1")	2
3	UP 03883	SPARK PLUG	1
4	UP 04690	LEAD-Electrical	1
5	•UP 03009	ROTOR KIT	1
6	UP 03906	WASHER-Flat	1
7	UP 04271	CONNECTOR-Drive (.250)	1
8	UP 02994	SHORT BLOCK (See Engine Internal)	1
<b>E</b>	•UP 02963	COMPLETE STARTER ASSEMBLY	1
9	UP 04164	SCREW-Thread Form (8-16 X 1/2")	3
10	UP 03013	BAFFLE-Air	1
11	UP 03012	PULLEY-Starter	1
12	UP 03912	ROPE-Starter (42")	1
13	UP 03917	SPRING & CONTAINER	1
14	UP 03026	GRIP-Starter (Yellow)	1
15	•UP 02964	HOUSING-Rear Kit	1
16	UP 03900	SCREW-Taptite (10-14 X 3/4")	2
17	UP 03406	SCREW-Taptite (10-24 X 3/4")	4
18	•UP 03113	CONTROL HANDLE ASSY.	1
19	UP 03015	TRIGGER-Throttle	1
20	UP 03027	PLUG-Switch	1
21	UP 03895	SCREW-Taptite (10-14 X 7/8")	4
22	UP 04247	SCREW-Truss Hd. (10-14 x 1")	4
23	UP 03020	CABLE-Throttle	1
24	•UP 03113	CONTROL HANDLE ASSY.	1
25	UP 03207	TRIGGER	1
26	UP 03172	CABLE-Throttle	1
27	UP 03210	SPRING	1
28	UP 04247	SCREW-Truss Hd. (10-14 x 1")	9

Beginning with Serial Number HA06100230

Item No.	Torque Specs		Required Loctite
	In/Lbs	Nm	
2	30-40	3.4-4.5	Blue 242
3	120-180	13.6-20.3	
7	100-150	11.3-16.9	
9	10-20	1.1-2.3	
16	30-50	3.4-5.6	
17	30-40	3.4-4.5	
21	30-50	3.4-5.6	
22	30-50	3.4-5.6	
28	30-50	3.4-5.6	

Warranty Flat Rate		
Job	Description	Time/Hr.
FA11	Ignition Mod.	.3
FA12	Ground Lead	.3
FG10	Starter	.4
FD12	Engine Housing, Rear	.4
FF13	Trigger, Throttle cable	.3

# IGNITION - ROTOR - STARTER

## Non-Clutch

Trim N' Edge™ ..... (UT20694, UT20697, UT20698,  
UT20702, UT20707, UT20728)  
Easy Reach™ ..... (UT20699, UT20703, UT20704,  
UT20730, UT20737, UT20738)  
ST2517CR ..... (UT20826R, UT20823)  
ST2537S ..... (UT20734R, UT20827)

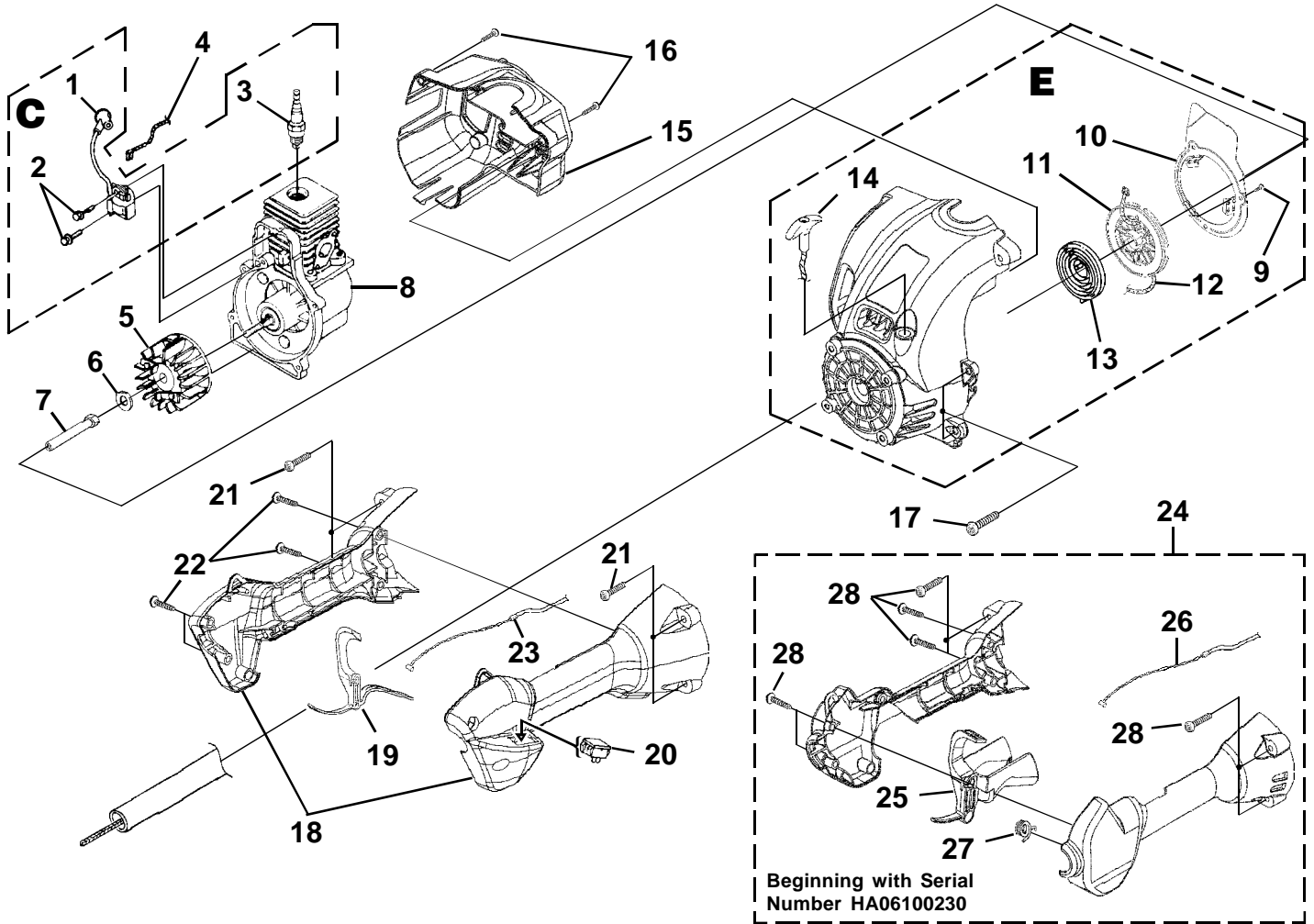

No.	Part No.	Description	Qty.
<b>C</b>	• A 07174	IGNITION KIT	1
1	UP 03868	TERMINAL & COVER	1
2	UP 03896	SCREW-Taptite (8-32 X 1")	2
3	UP 03883	SPARK PLUG	1
4	UP 04690	LEAD-Electrical	1
5	•UP 03009	ROTOR KIT	1
6	UP 03906	WASHER-Flat	1
7	UP 04271	CONNECTOR-Drive (.250)	1
8	UP 02994	SHORT BLOCK (See Engine Internal)	1
<b>E</b>	•UP 02962	COMPLETE STARTER ASSEMBLY	1
9	UP 04164	SCREW-Thread Form (8-16 X 1/2")	3
10	UP 03013	BAFFLE-Air	1
11	UP 03012	PULLEY-Starter	1
12	UP 03912	ROPE-Starter (42")	1
13	UP 03917	SPRING & CONTAINER	1
14	UP 03026	GRIP-Starter (Yellow)	1
15	•UP 02965	HOUSING-Rear Kit	1
16	UP 03895	SCREW-Taptite (10-14 X 7/8")	2
17	UP 03406	SCREW-Taptite (10-24 X 3/4")	4
18	•UP 03113	CONTROL HANDLE ASSY.	1
19	UP 03015	TRIGGER-Throttle	1
20	UP 03027	PLUG-Switch	1
21	UP 03895	SCREW-Taptite (10-14 X 7/8")	4
22	UP 04247	SCREW-Truss Hd. (10-14 x 1")	4
23	UP 03020	CABLE-Throttle	1
28	UP 04247	SCREW-Truss Hd. (10-14 x 1")	9

No.	Part No.	Description	Qty.
2 4	•UP 03113	CONTROL HANDLE ASSY.	1
2 5	UP 03207	TRIGGER	1
2 6	UP 03172	CABLE-Throttle	1
2 7	UP 03210	SPRING	1
2 8	UP 04247	SCREW-Truss Hd. (10-14 x 1")	9

Torque Specs			
Item No.	In/Lbs	Nm	Required Loctite
2	30-40	3.4-4.5	Blue 242
3	120-180	13.6-20.3	
7	100-150	11.3-16.9	
9	10-20	1.1-2.3	
16	30-50	3.4-5.6	
17	30-40	3.4-4.5	
21	30-50	3.4-5.6	
22	30-50	3.4-5.6	
28	30-50	3.4-5.6	

Warranty Flat Rate		
Job	Description	Time/Hr.
FA11	Ignition Mod.	.3
FA12	Ground Lead	.3
FG10	Starter	.4
FD12	Engine Housing, Rear	.4
FF13	Trigger, Throttle cable	.3

**Clutch**

d825ca ..... (UT20711, UT20736)  
 d825sb ..... (UT15152, UT15160)

**IGNITION - ROTOR - STARTER - CLUTCH**

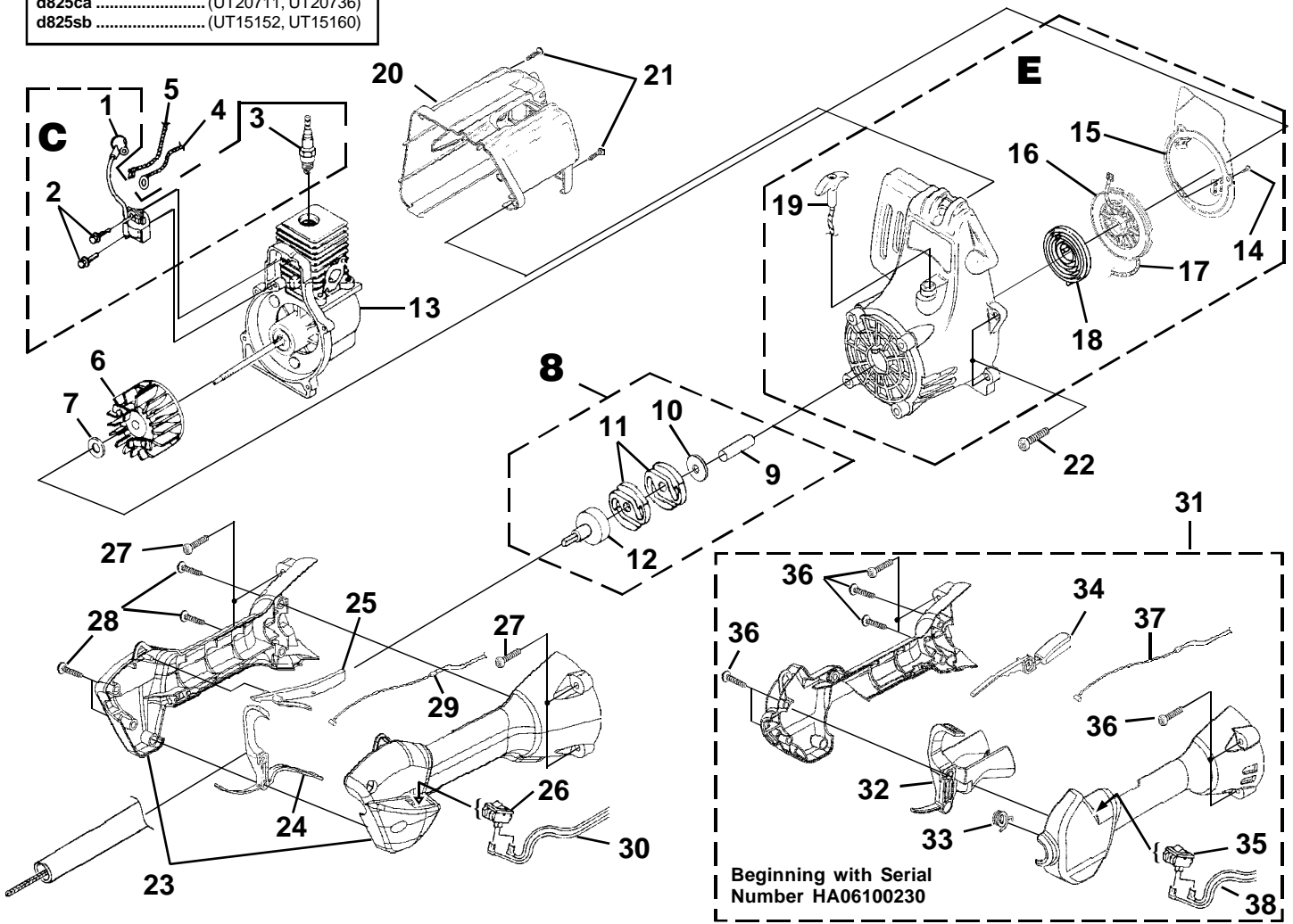

No.	Part No.	Description	Qty.
<b>C</b>	• A 07174	IGNITION KIT	1
1	UP 03868	TERMINAL & COVER	1
2	UP 03896	SCREW-Taptite (8-32 X 1")	2
3	UP 03883	SPARK PLUG	1
4	UP 04537	LEAD-Electrical	1
5	UP 04536	LEAD-Electrical	1
6	•UP 03009	ROTOR KIT	1
7	UP 04241	WASHER-Flat	1
8	•UP 00034	CLUTCH AND DRUM KIT	1
9	UP 04118	SPACER	1
10	UP 04275	WASHER-Flat	1
11	UP 04103	CLUTCH	2
12	UP 04104	CONNECTOR AND DRUM	1
13	UP 02995	SHORT BLOCK (See Engine Internal)	1
<b>E</b>	•UP 02963	COMPLETE STARTER ASSEMBLY	1
14	UP 04164	SCREW-Thread Form (8-16 X 1/2")	3
15	UP 03013	BAFFLE-Air	1
16	UP 03012	PULLEY-Starter	1
17	UP 03912	ROPE-Starter (42")	1
18	UP 03917	SPRING & CONTAINER	1
19	UP 03026	GRIP-Starter (Yellow)	1
20	•UP 02964	HOUSING-Rear Kit	1
21	UP 03900	SCREW-Plastite (10-14 X 3/4")	2
22	UP 03406	SCREW-Taptite (10-24 X 3/4")	4
23	•UP 02967	CONTROL HANDLE ASSY.	1
24	UP 03015	TRIGGER-Throttle	1
25	UP 03014	THROTTLE INTERLOCK	1
26	UP 03833	SWITCH	1
27	UP 03895	SCREW-Taptite (10-14 X 7/8")	4
28	UP 03406	SCREW-Taptite (10-24 X 3/4")	4
29	UP 03020	CABLE-Throttle	1
30	UP 04566	LEAD-Electrical	1

No.	Part No.	Description	Qty.
31	•UP 03114	CONTROL HANDLE ASSY.	1
32	•UP 03207	TRIGGER-Throttle	1
33	UP 03210	SPRING	1
34	UP 03173	THROTTLE INTERLOCK	1
35	UP 04197	SWITCH	1
36	UP 04247	SCREW-Taptite (10-14 X 1")	9
37	UP 03172	CABLE-Throttle	1
38	UP 03174	LEAD-Electrical	1

Torque Specs			
Item No.	In/Lbs	Nm	Required Loctite
2	30-40	3.4-4.5	Blue 242
3	120-180	13.6-20.3	
14	10-20	1.1-2.3	
21	30-50	3.4-5.6	
22	30-40	3.4-4.5	
27	30-50	3.4-5.6	
28	30-50	3.4-5.6	
36	30-50	3.4-5.6	

Warranty Flat Rate		
Job	Description	Time/Hr.
FA11	Ignition Mod.	.3
FA12	Ground Lead	.3
FG10	Starter	.4
FD12	Engine Housing, Rear	.4
FF13	Trigger, Throttle cable	.3

# IGNITION - ROTOR - STARTER - CLUTCH

**Clutch**  
 Expand-it™ ..... (UT20710, UT20712, UT20735)  
 VersaTool™ ..... (UT15151, UT15154, UT15157,  
 UT20722, UT20723)  
 BC2500MR ..... (UT15159R, UT15204)

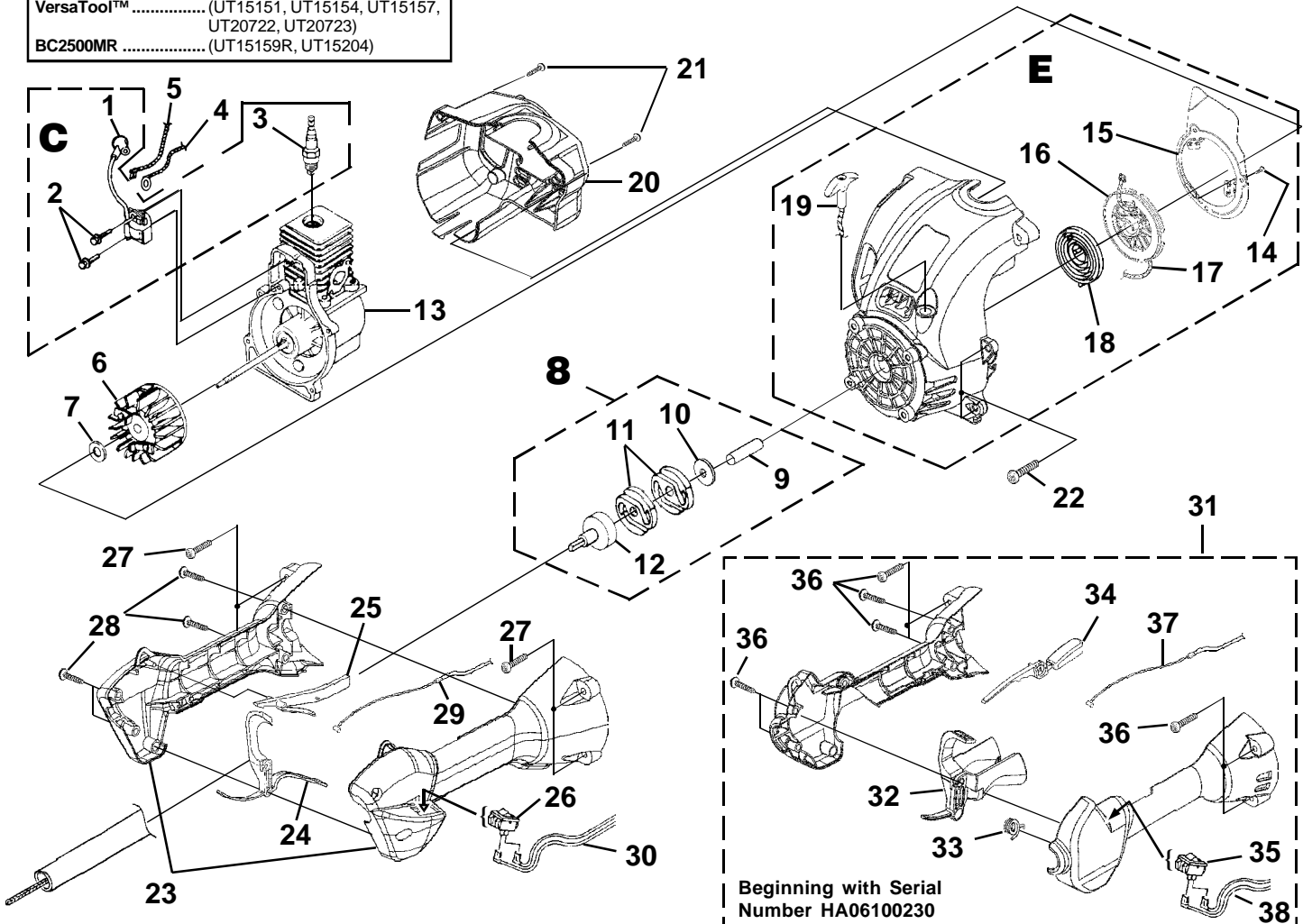

No.	Part No.	Description	Qty.
<b>C</b>	• A 07174	IGNITION KIT	1
1	UP 03868	TERMINAL & COVER	1
2	UP 03896	SCREW-Taptite (8-32 X 1")	2
3	UP 03883	SPARK PLUG	1
4	UP 04537	LEAD-Electrical	1
5	UP 04536	LEAD-Electrical	1
6	•UP 03009	ROTOR KIT	1
7	UP 04241	WASHER-Flat	1
8	•UP 00034	CLUTCH AND DRUM KIT	1
9	UP 04118	SPACER	1
10	UP 04275	WASHER-Flat	1
11	UP 04103	CLUTCH	2
12	UP 04104	CONNECTOR AND DRUM	1
13	UP 02995	SHORT BLOCK (See Engine Internal)	1
<b>E</b>	•UP 02962	COMPLETE STARTER ASSEMBLY	1
14	UP 04164	SCREW-Thread Form (8-16 X 1/2")	3
15	UP 03013	BAFFLE-Air	1
16	UP 03012	PULLEY-Starter	1
17	UP 03912	ROPE-Starter (42")	1
18	UP 03917	SPRING & CONTAINER	1
19	UP 03026	GRIP-Starter (Yellow)	1
20	•UP 02965	HOUSING-Rear Kit	1
21	UP 03895	SCREW-Plastite (10-14 X 7/8")	2
22	UP 03406	SCREW-Taptite (10-24 X 3/4")	4
23	•UP 02967	CONTROL HANDLE ASSY.	1
24	UP 03015	TRIGGER-Throttle	1
25	UP 03014	THROTTLE INTERLOCK	1
26	UP 03833	SWITCH	1
27	UP 03895	SCREW-Taptite (10-14 X 7/8")	4
28	UP 03406	SCREW-Taptite (10-24 X 3/4")	4
29	UP 03020	CABLE-Throttle	1
30	UP 04566	LEAD-Electrical	1

No.	Part No.	Description	Qty.
31	•UP 03114	CONTROL HANDLE ASSY.	1
32	•UP 03207	TRIGGER-Throttle	1
33	UP 03210	SPRING	1
34	UP 03173	THROTTLE INTERLOCK	1
35	UP 04197	SWITCH	1
36	UP 04247	SCREW-Taptite (10-14 X 1")	9
37	UP 03172	CABLE-Throttle	1
38	UP 03174	LEAD-Electrical	1

Torque Specs				
Item No.	In/Lbs	Nm	Required	Loctite
2	30-40	3.4-4.5	Blue	242
3	120-180	13.6-20.3		
14	10-20	1.1-2.3		
21	30-50	3.4-5.6		
22	30-40	3.4-4.5		
27	30-50	3.4-5.6		
28	30-50	3.4-5.6		
36	30-50	3.4-5.6		

Warranty Flat Rate		
Job	Description	Time/Hr.
FA11	Ignition Mod.	.3
FA12	Ground Lead	.3
FG10	Starter	.4
FD12	Engine Housing, Rear	.4
FF13	Trigger, Throttle cable	.3

03/08/2001

**Non-Clutch**

- EasyTrim™ ..... (UT20693)
- d825cdp ..... (UT20705)
- d825cde ..... (UT20695, UT20713)
- d825sd ..... (UT20700, UT20701, UT20709, UT20729)
- Trim N' Edge™ ..... (UT20694, UT20697, UT20698, UT20702, UT20707, UT20728)
- Easy Reach™ ..... (UT20699, UT20703, UT20704, UT20730, UT20737, UT20738)
- ST2517CR ..... (UT20726R, UT20823)
- ST2537S ..... (UT20734R, UT20827)

**Clutch**

- Expand-it™ ..... (UT20710, UT20712, UT20735)
- VersaTool™ ..... (UT15151, UT15154, UT15157, UT20722, UT20723)
- d825ca ..... (UT20711, UT20736)
- d825sb ..... (UT15152, UT15160)
- BC2500MR ..... (UT15159R, UT15204)

**ENGINE INTERNAL**

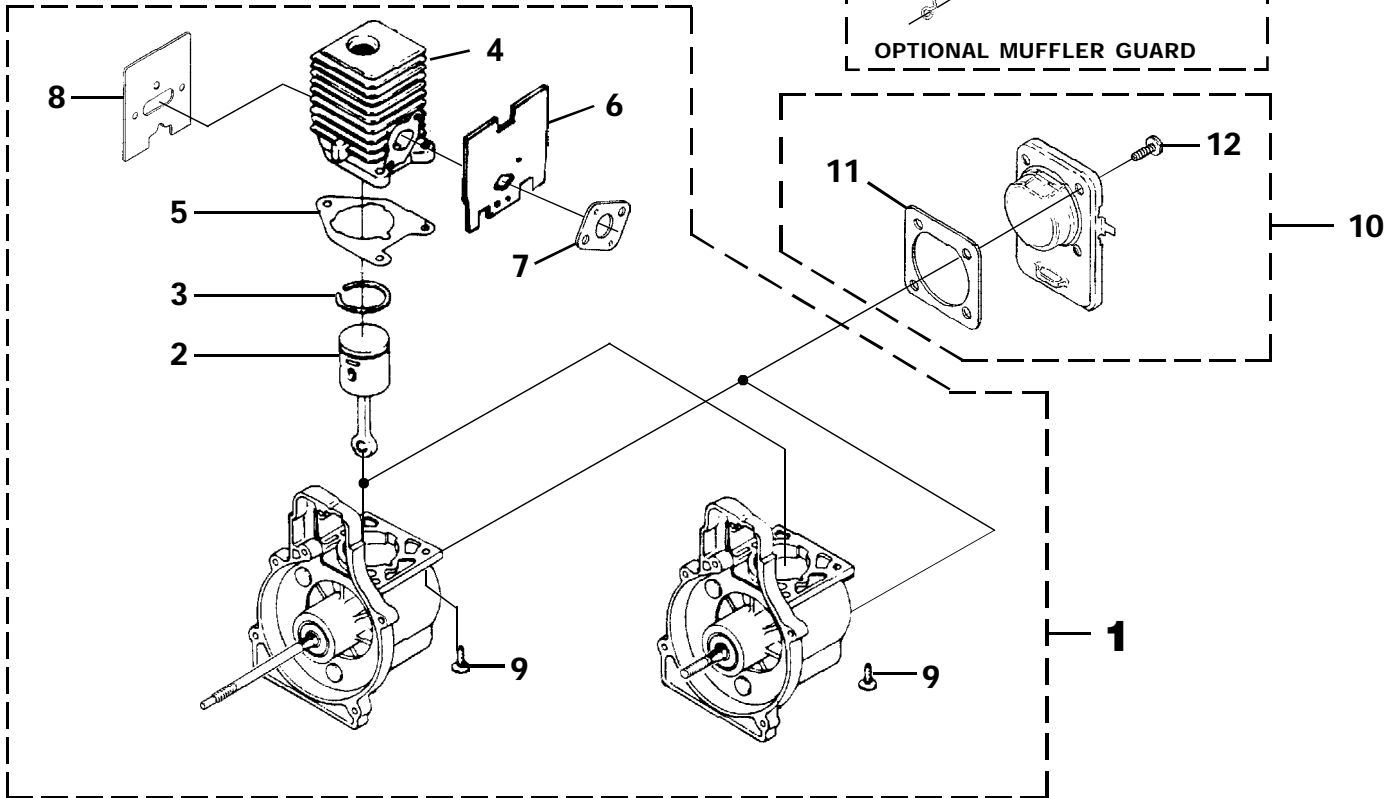

No.	Part No.	Description	Qty.
1	●UP 02994	SHORT BLOCK (Non-Clutch)	1
	●UP 02995	SHORT BLOCK (Clutch)	1
2	●UP 00768	PISTON & ROD ASSY.	1
	PS 01359	RING-Piston	1
4	●UP 04136	CYLINDER ASSY.	1
5	UP 03857	GASKET-Cylinder	1
6	UP 04308	GASKET-Heat Dam	1
7	UP 03916	GASKET-Carburetor	1
8	UP 04710	GASKET-Muffler	1
9	UP 04345	SCREW-Sems (12-24 X 3/4")	3
10	●UP 00019	CRANKCASE COVER ASSEMBLY	1
11	UP 04335	GASKET-Crankcase Cover (Also included w/short block)	1
12	UP 04295	SCREW-Sems (10-24 X 1/2")	4
13	●UP 00027	MUFFLER GUARD	3
14	UP 03897	SCREW-Plastite (10-14 X 1/2")	2

Item No.	Torque Specs		Required Loctite
	In/Lbs	Nm	
9	55-65	6.2-7.3	Red 262
12	35-45	4.0-5.1	Red 262
14	5-20	.6-2.3	

Warranty Flat Rate		
Job	Description	Time/Hr.
FB10	.... Partial Rebuild	1.0
FB20	.... Short Block	1.0
FD25	.... Crankcase Cover	.3

# CARBURETOR - FUEL TANK

## Non-Clutch

EasyTrim™	(UT20693)
d825cdp	(UT20705)
d825cde	(UT20695, UT20713)
d825sd	(UT20700, UT20701, UT20709, UT20729)
Trim N' Edge™	(UT20694, UT20697, UT20698, UT20702, UT20707, UT20728)
Easy Reach™	(UT20699, UT20703, UT20704, UT20730, UT20737, UT20738)
ST2517CR	(UT20726R, UT20823)
ST2537S	(UT20734R, UT20827)

## Clutch

Expand-it™	(UT20710, UT20712, UT20735)
VersaTool™	(UT15151, UT15154, UT15157, UT20722, UT20723)
d825ca	(UT20711, UT20736)
d825sb	(UT15152, UT15160)
BC2500MR	(UT15159R, UT15204)

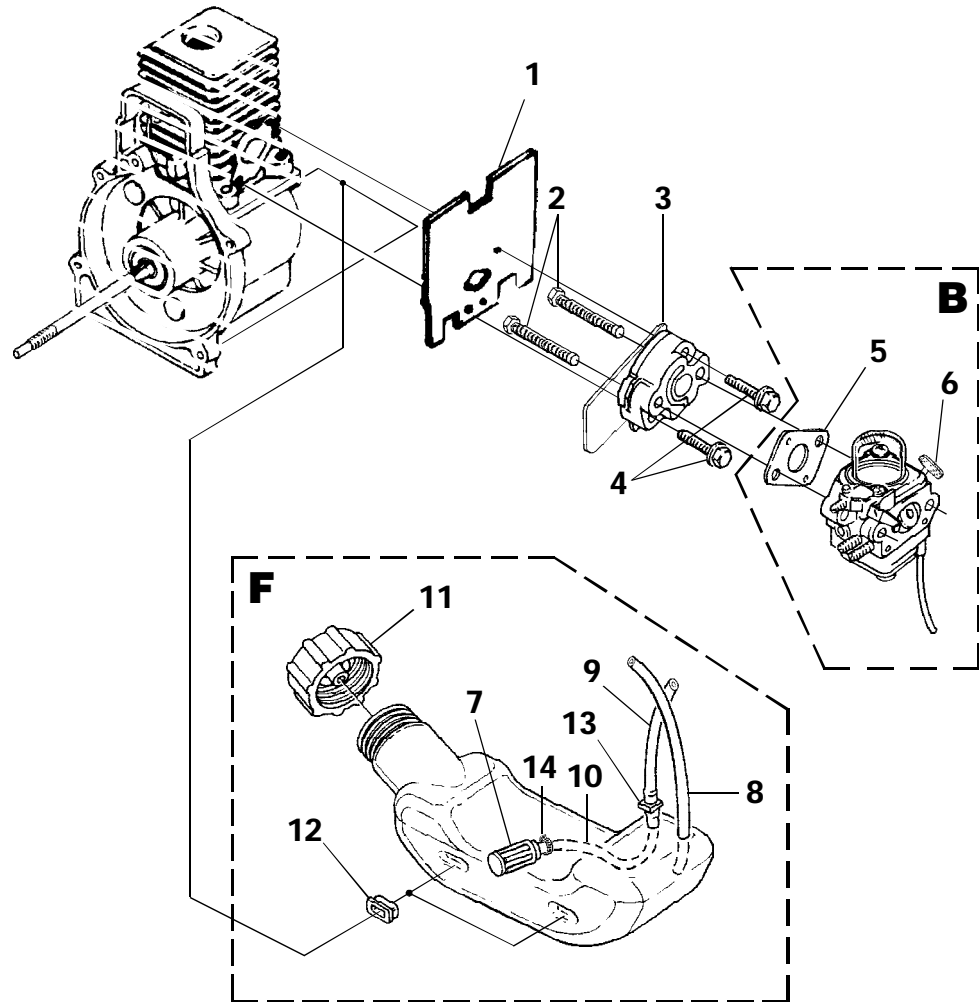

No.	Part No.	Description	Qty.
1	UP 04308	GASKET-Heat Dam	1
2	UP 04131	SCREW-Machine (10-24 X 2 1/4")	2
3	UP 04348	HEAT DAM	1
4	UP 04140	SCREW-Sems (10-24 X 1")	2
<b>B</b>	•UP 00608	CARBURETOR KIT (Non-Clutch)	1
	•UP 00654	CARBURETOR KIT (Clutch)	1
5	UP 03916	GASKET-Carburetor	1
6	UP 04278	Lever-Choke (Zama)	1
<b>F</b>	•UP 00020	FUEL TANK ASSY.	1
7	UP 03871	FILTER-Fuel	1
8	UP 04293	TUBING-Rubber	1
9	UP 04292	TUBING-Rubber	1
10	UP 04715	TUBING-Rubber	1
11	UP 00106	FUEL CAP	1
12	UP 03501	BUMPER-Rubber	3
13	UP 03831	FITTING-Inline	1
14	UP 03913	CLAMP	1

Item No.	Torque Specs		Required Loctite
	In/Lbs	Nm	
4	35-45	4.0-5.1	Red 262

Warranty Flat Rate		
Job	Description	Time/Hr.
FF17	Manifold	.3
FF10	Carburetor Rep.	.3
FF16	Fuel Tank	.3
FF12	Fuel/Return Line	.3

# MUFFLER - AIR CLEANER

## Non-Clutch

EasyTrim™	.....	(UT20693)
d825cdp	.....	(UT20705)
d825cde	.....	(UT20695, UT20713)
d825sd	.....	(UT20700, UT20701, UT20709, UT20729)
Trim N' Edge™	.....	(UT20694, UT20697, UT20698, UT20702, UT20707, UT20728)
Easy Reach™	.....	(UT20699, UT20703, UT20704, UT20730, UT20737, UT20738)
ST2517CR	.....	(UT20726R, UT20823)
ST2537S	.....	(UT20734R, UT20827)

## Clutch

Expand-it™	.....	(UT20710, UT20712, UT20735)
VersaTool™	.....	(UT15151, UT15154, UT15157, UT20722, UT20723)
d825ca	.....	(UT20711, UT20736)
d825sb	.....	(UT15152, UT15160)
BC2500MR	.....	(UT15159R, UT15204)

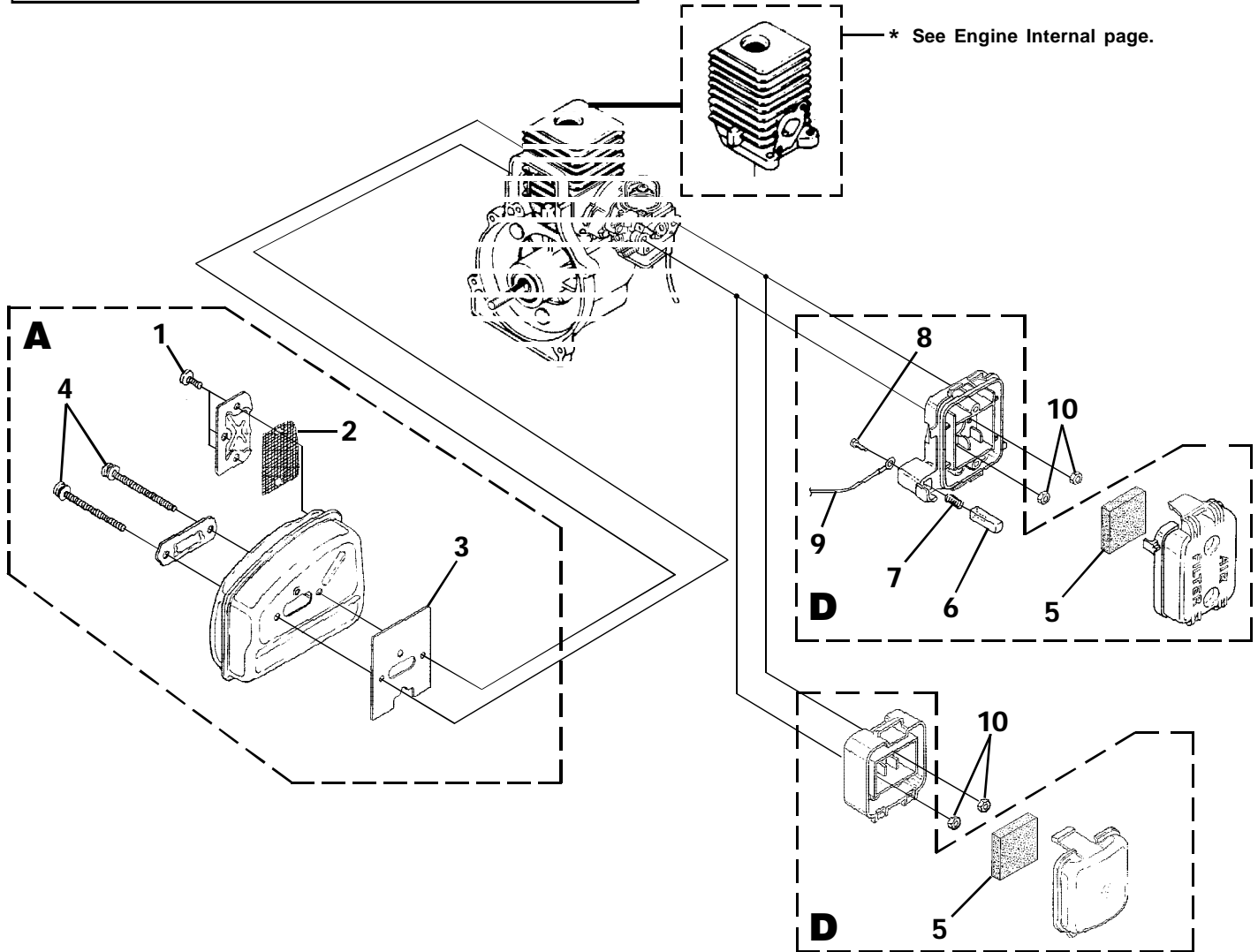

No.	Part No.	Description	Qty.
<b>A</b>	•UP 04634	MUFFLER ASSY.	1
1	UP 04248	SCREW, Taptite- (8-32 X 3/8")	3
2	UP 04629	SCREEN-Spark	1
3	UP 04710	GASKET-Muffler	1
4	UP 04258	SCREW, Truss Hd. - (10-24 X 2.188)	2
<b>D</b>	• A 04707 A	AIR FILTER KIT (Non-Clutch)	1
5	D 98760 B	FILTER-Air	1
6	UP 06341	BUTTON-Switch	1
7	UP 04716	SPRING-Compression	1
8	UP 04082	SCREW-Thread Form (6-19 x 1/2")	1
9	UP 04690	LEAD-Electrical	1
10	UP 03885	NUT-Hex (10-24)	2
<b>D</b>	•UP 00022	AIR FILTER KIT (Clutch)	1
5	D 98760 B	FILTER-AIR	1
10	UP 03885	NUT-Hex (10-24)	2

Item No.	Torque Specs		Required Loctite
	In/Lbs	Nm	
1	25-35	2.8-4.0	
4	50-60	5.6-6.8	
8	5-10	.6-1.1	
10	30-40	3.4-4.5	

Warranty Flat Rate		
Job	Description	Time/Hr.
FB18	Muffler-Replace	.3
FF42	Air Filter Assy.	.2



# SHAFT - SPOOL & STRING - GRASS DEFLECTOR

EasyTrim™ ..... (UT20693, UT20705)  
 ST2517 CR ..... (UT20726R, UT20823)

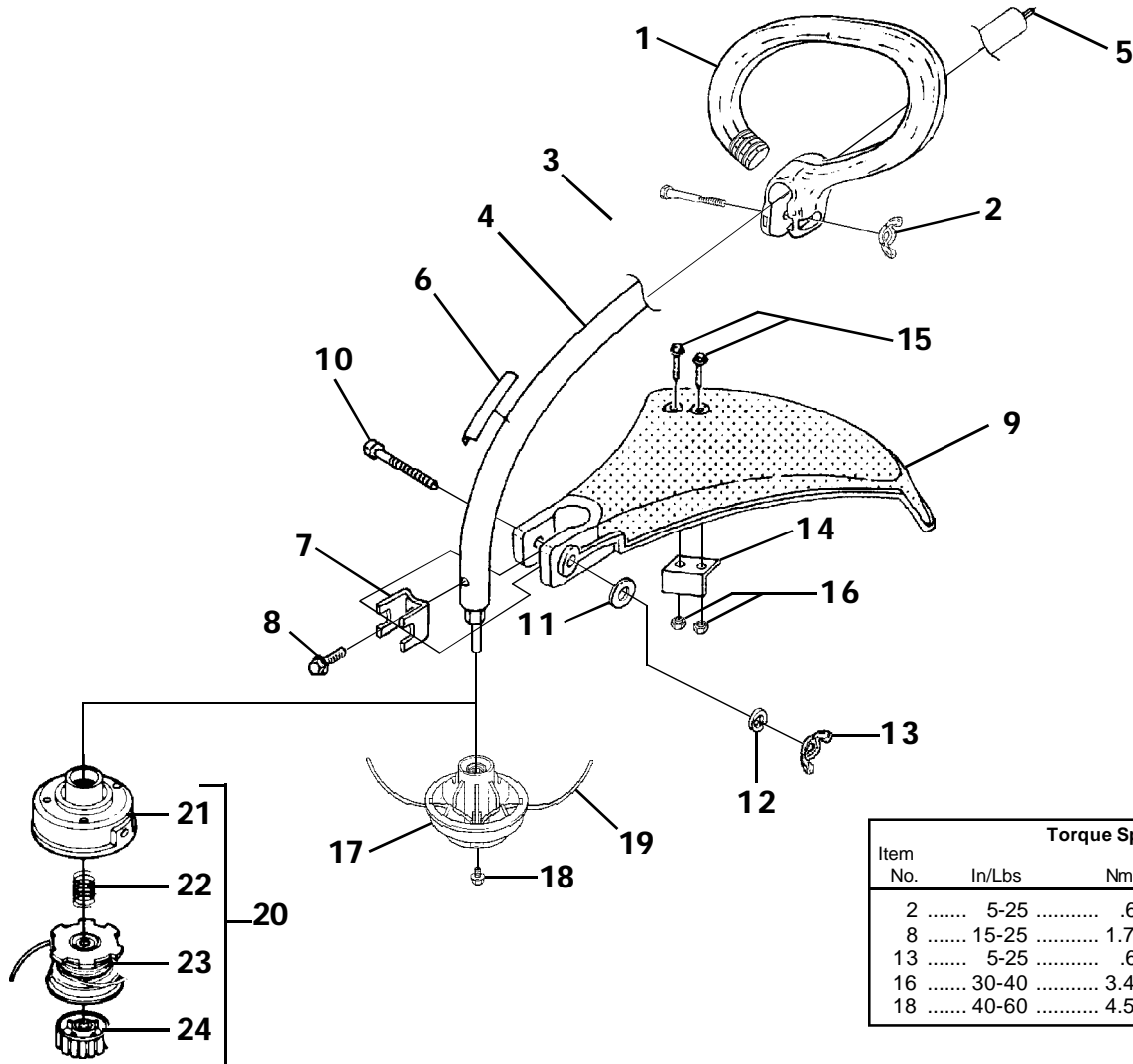

Item No.	Torque Specs		Required Loctite
	In/Lbs	Nm	
2	5-25	.6-2.8	
8	15-25	1.7-2.8	
13	5-25	.6-2.8	
16	30-40	3.4-4.5	
18	40-60	4.5-6.8	

No.	Part No.	Description	Qty.
1	•UP 06959	HANDLE-Anti-Vibe	1
2	UP 04262	NUT-Wing, Washer Faced (1/4-20)	1
3	UP 06523	SCREW-Cap Hex Hd.	1
4	•UP 00710	DRIVESHAFT HOUSING ASSY.	1
5	UP 03031	SHAFT-Flexible	1
6	UP 04352	DECAL-Warning	1
7	UP 04137	CLAMP	1
8	UP 04256	SCREW-Sems Hex Hd. (#10-24 X 3/8")	1
9	•UP 06710	DEFLECTOR & BLADE KIT (55 Deg.)	1
10	UP 06523	SCREW-Cap Hex Hd. (10-24 X 2")	1
11	UP 03415	WASHER-Flat (1/4")	1
12	UP 03409	WASHER-Lock (1/4")	1
13	UP 04262	NUT-Wing, Washer Faced (1/4-20)	1
14	•UP 04119	BLADE-Cut-Off	1
15	UP 04159	SCREW-Mech. Hex Hd. (10-24 X 7/8")	2
16	UP 03885	NUT-Hex (10-24)	2
17	•DA 09364	STRINGHEAD-Pro-Cut w/line (UT20693, UT20705)	1
18	UP 04102	SCREW (5/16-18 x 5/8")	1
19	D 09365	LINE-Replacement	1

No.	Part No.	Description	Qty.
20	•DA 03001 A	STRINGHEAD-Complete (.080") (UT20726R, UT20823)	1
21	UP 06567	HOUSING & EYELET (Dual Line)	1
22	UP 06526	SPRING-Compression	1
23	UP 00145	SPOOL & STRING (.080")	1
24	DA 98866 A	RETAINER-Spool (R.H. Thread, Black)	1

Warranty Flat Rate		
Job	Description	Time/Hr.
FM10	Stringhead Assy.	.2
FN12	Driveshaft	.3
FN13	Driveshaft Hsg.	.3
FN16	Deflector-Grass	.2
FD20	Front Handle	.2

# SHAFT - SPOOL & STRING - GRASS DEFLECTOR

Trim N' Edge™ .... (UT20694, UT20697, UT20698, UT20702, UT20707),  
 UT20728  
 d725cde ..... (UT20695, UT20713)

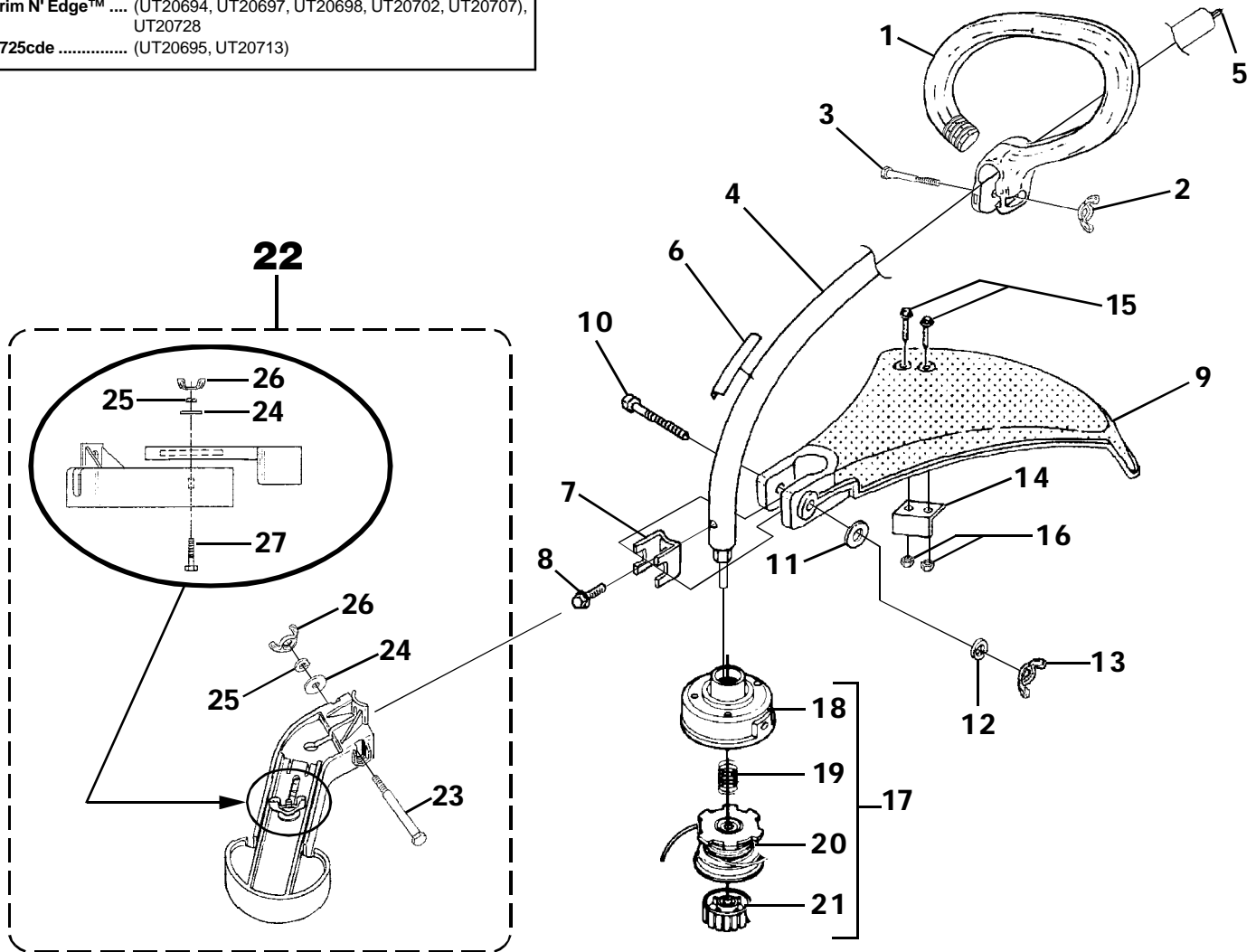

No.	Part No.	Description	Qty.
1	•UP 06959	HANDLE-Anti-Vibe	1
2	UP 04262	NUT-Wing, Washer Faced (1/4-20)	1
3	•UP 06523	SCREW-Cap Hex Hd.	1
4	•UP 00710	DRIVESHAFT HOUSING ASSY.	1
5	UP 03031	SHAFT-Flexible	1
6	UP 04352	DECAL-Warning	1
7	UP 04137	CLAMP	1
8	UP 04256	SCREW-Sems Hex Hd. (#10-24 X 3/8")	1
9	•UP 06710	DEFLECTOR & BLADE KIT (55 Deg.)	1
10	UP 06523	SCREW-Cap Hex Hd. (10-24 X 2")	1
11	UP 03415	WASHER-Flat (1/4")	1
12	UP 03409	WASHER-Lock (1/4")	1
13	UP 04262	NUT-Wing, Washer Faced (1/4-20)	1
14	•UP 04119	BLADE-Cut-Off	1
15	UP 04159	SCREW-Mech. Hex Hd. (10-24 X 7/8")	2
16	UP 03885	NUT-Hex (10-24)	2
17	•DA 03001 A	STRINGHEAD-Complete (.080") (UT20694, UT20697, UT20702, UT20728)	1
	•DA 04591 A	STRINGHEAD-Complete (.095") (UT20695, UT20698, UT20707, UT20713)	1
18	UP 06567	HOUSING & EYELET (Dual Line)	1
19	UP 06526	SPRING-Compression	1
20	UP 00145	SPOOL & STRING (.080")	1
	UP 00147	SPOOL & STRING (.095")	1
21	DA 98866 A	RETAINER-Spool (R.H. Thread, Black)	1

No.	Part No.	Description	Qty.
22	•UP 00008	EDGER GUIDE KIT	1
23	UP 04148	SCREW-Hex Hd. (1/4-20 X 2 1/2")	1
24	UP 03415	WASHER-Flat (1/4")	2
25	UP 03409	WASHER-Lock (1/4")	2
26	UP 04262	NUT-Wing, Washer Faced (1/4-20)	2
27	UP 04158	SCREW-Hex Hd. (1/4-20 X 1")	1

Torque Specs			
Item No.	In/Lbs	Nm	Required Loctite
2	5-25	.6-2.8	
8	15-25	1.7-2.8	
13	5-25	.6-2.8	
16	30-40	3.4-4.5	
26	5-25	.6-2.8	

Warranty Flat Rate		
Job	Description	Time/Hr.
FM10	Stringhead Assy.	.2
FN12	Driveshaft	.3
FN13	Driveshaft Hsg.	.3
FN16	Deflector-Grass	.2
FD20	Front Handle	.2
FN25	Edger Attachment-Replace	.2

# SHAFT - SPOOL & STRING - GRASS DEFLECTOR

Expand-it™ ..... (UT20710, UT20712,  
UT20735)  
d825ca ..... (UT20711, UT20736)

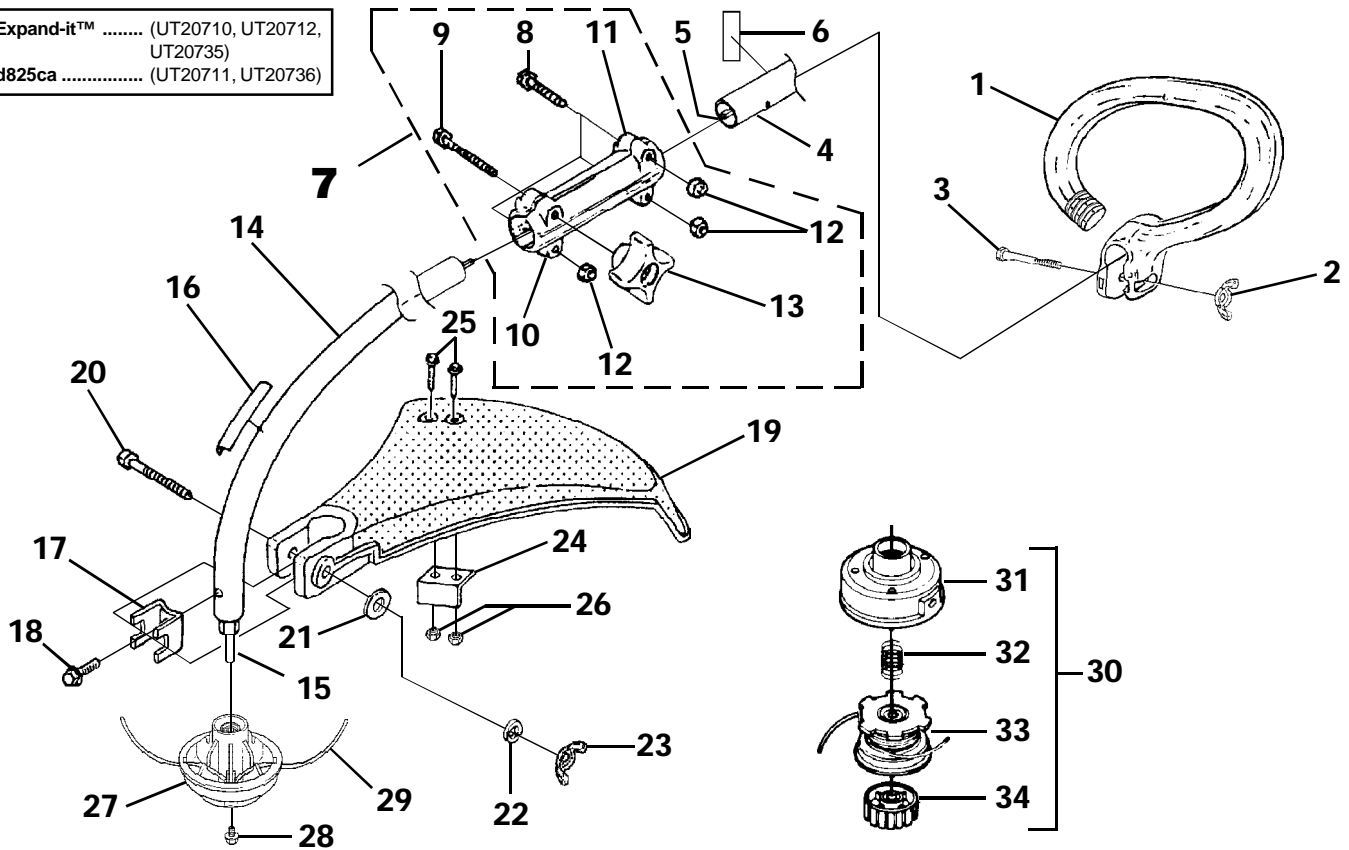

No.	Part No.	Description	Qty.
1	●UP 06959	HANDLE-Anti-Vibe	1
2	UP 04262	NUT-Wing, Washer Faced (1/4-20)	1
3	UP 06523	SCREW-Cap Hex Hd. (1/4-20 x 2")	1
4	●UP 00029	DRIVESHAFT ASSY. (Upper)	1
5	A 07667	FLEXSHAFT w/Collar & Liner	1
6	UP 04116	DECAL-Warning	1
7	●A 07901	COUPLER ASSEMBLY	1
8	UP 04153	SCREW-Hex Hd. (1/4-20 x 1 1/2")	3
9	UP 06523	SCREW-Cap Hex (1/4-20 x 2")	1
10	UP 04143	COUPLER (L.H.)	1
11	UP 04144	COUPLER (R.H.)	1
12	UP 03400	NUT-Hex (1/4-20)	3
13	UP 04138	KNOB (1/4-20)	1
14	●UP 02887	DRIVESHAFT HOUSING (Lower)	1
15	UP 04541	SHAFT-Flex	1
16	UP 04352	DECAL-Warning	1
17	UP 04137	CLAMP	1
18	UP 04256	SCREW-Sems Hex (10-24 X 3/8")	1
19	●UP 06710	DEFLECTOR & BLADE KIT (55 Deg.)	1
20	UP 06523	SCREW-Cap Hex Hd. (10-24 X 2")	1
21	UP 03415	WASHER-Flat (1/4")	1
22	UP 03409	WASHER-Lock (1/4")	1
23	UP 04262	NUT-Wing, Washer Faced (1/4-20)	1
24	●UP 04119	BLADE-Cut-Off	1
25	UP 04159	SCREW-Mech. Hex Hd. (10-24 X 7/8")	2
26	UP 03885	NUT-Hex (10-24)	2
27	●DA 09364	STRINGHEAD-Pro-Cut w/line (UT20710,	1
28	UP 04102	SCREW-(5/16-18 x 5/8")	1
29	D 09365	LINE-Replacement	1
30	●DA 03001 A	STRINGHEAD-Complete (.080") (UT20712)	1
	●DA 04591 A	STRINGHEAD-Complete (.095") (UT20711, UT20736)	1
31	UP 06567	HOUSING & EYELET (Dual Line)	1
32	UP 06526	SPRING-Compression	1
33	UP 00145	SPOOL & STRING (.080")	1
	UP 00147	SPOOL & STRING (.095")	1
34	DA 98866 A	RETAINER-Spool (R.H. Thread, Black)	1

Torque Specs			
Item No.	In/Lbs	Nm	Required Loctite
2	5-25	.6-2.8	
12	50-60	5.7-6.8	
13	Hand Tight		
18	15-25	1.7-2.8	
23	5-25	.6-2.8	
26	30-40	3.4-4.5	
28	40-60	4.5-6.8	

Warranty Flat Rate		
Job	Description	Time/Hr.
FM10	Stringhead Assy.	.2
FN12	Driveshaft (Upper)	.3
FN13	Driveshaft Housing	.3
FN16	Deflector	.2
CD98	Coupler-Shaft	.3

**\*ATTACHMENTS for Expand-it™**

See Parts Lists on:

Page 14

Page 15

Page 17

Page 16

# SHAFT - SPOOL & STRING - GRASS DEFLECTOR

Easy Reach™ ..... (UT20699, UT20703, UT20704, UT20730, UT20737, UT20738)  
 d825sd ..... (UT20700, UT20701, UT20709, UT20729)  
 ST2537S ..... (UT20734R, UT20827)

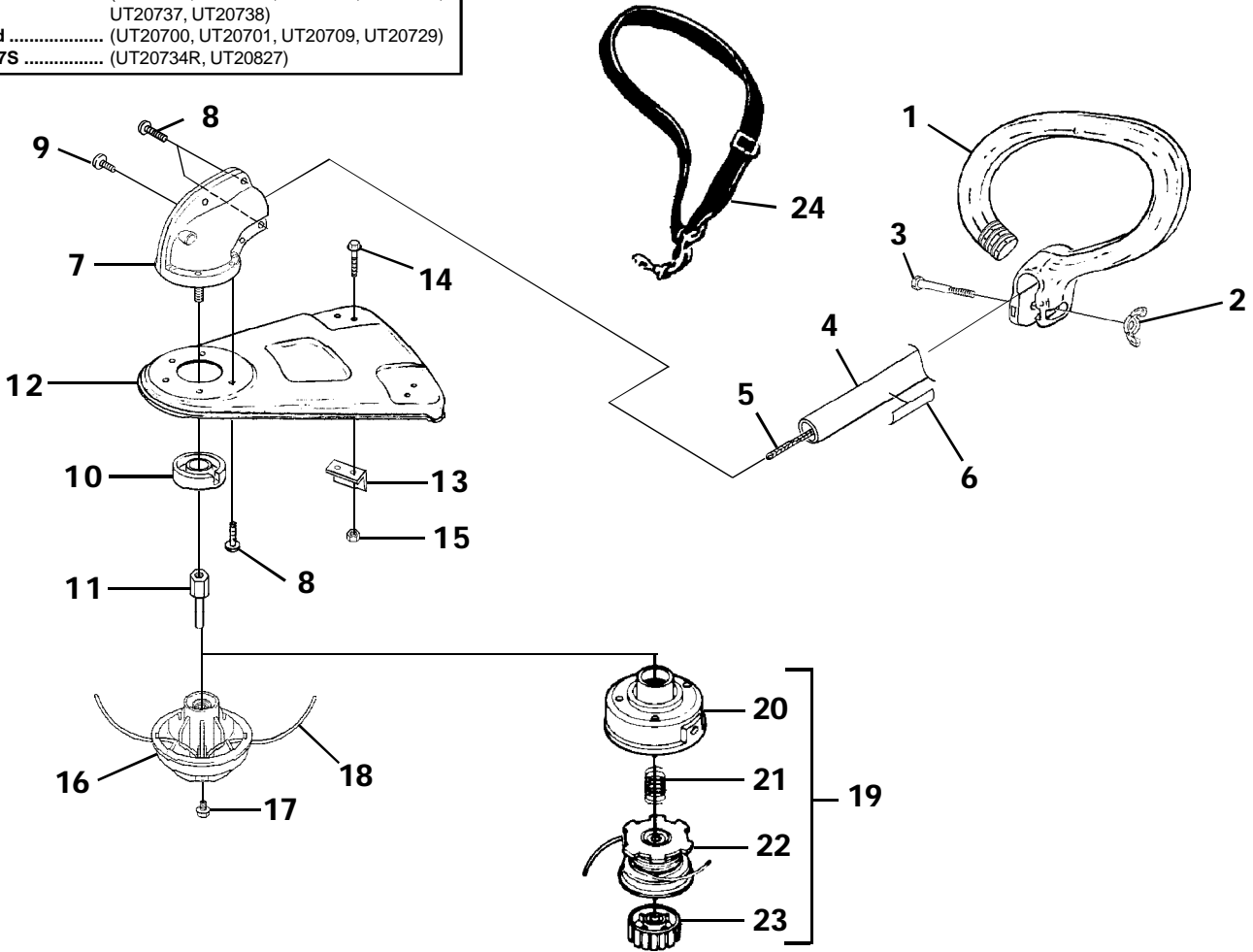

No.	Part No.	Description	Qty.
1	•UP 06959	HANDLE-Anti-Vibe	1
2	UP 04262	NUT-Wing, Washer Faced (1/4-20)	1
3	UP 06523	SCREW-Cap Hex Hd. (1/4-20 x 2")	1
4	•UP 02968	DRIVESHAFT HOUSING ASSY.	1
5	UP 04717	SHAFT-Flexible	1
6	UP 04352	DECAL-Warning	1
7	•UP 06970	GEARHEAD	1
8	UP 04157	Screw, Tapite Hex Hd. (10-24 x 1/2")	5
9	UP 04155	Screw-Hex Hd. (10-24 x 5/8")	2
10	UP 04126	WASHER-Flanged	1
11	UP 04128	ADAPTER-Shaft	1
12	• A 04683 A	GRASS DEFLECTOR KIT	1
13	UP 04538	BLADE-Cut-off	1
14	UP 04149	SCREW-Mach.Hex Hd. (10-24 X 3/8")	2
15	UP 03885	NUT-Lock Hex (10-24)	2
16	•DA 09364	STRINGHEAD-Pro-Cut w/line (UT20699, UT20703, UT20701, UT20730, UT20729, UT20737)	1
17	UP 04102	SCREW (5/16-18 x 5/8")	1
18	D 09365	LINE-Replacement	1
19	•DA 03001 A	STRINGHEAD-Complete (.080") (UT20704, UT20738, UT20734R, UT20827)	1
	•DA 04591 A	STRINGHEAD-Complete (.095") (UT20700, UT20709)	1
20	UP 06567	HOUSING & EYELET (Dual Line)	1
21	UP 06526	SPRING-Compression	1
22	UP 00145	SPOOL & STRING (.080")	1
	UP 00147	SPOOL & STRING (.095")	1
23	DA 98866 A	RETAINER-Spool (R.H. Thread, Black)	1
24	UP 00108	HARNESS	1

Torque Specs			
Item No.	In/Lbs	Nm	Required Loctite
2	5-25	.6-2.8	
8	15-20	1.7-2.3	
9	40-50	4.5-5.6	
11	100-120	11.3-13.6	
15	30-40	3.4-4.5	
17	40-60	4.5-6.8	

Warranty Flat Rate		
Job	Description	Time/Hr.
FM10	Stringhead Assy.	.2
FN12	Driveshaft	.3
FN13	Driveshaft Hsg.	.3
FN15	Gearhead	.3
FD20	Front Handle	.2

# SHAFT - SPOOL & STRING - GRASS DEFLECTOR - BLADE GUARD - BLADE

VersaTool™ ..... (UT15151, UT15154, UT20722, UT20723, UT15157)  
 d825sb ..... (UT15152, UT15160)  
 BC2500MR ..... (UT15159R, UT15204)

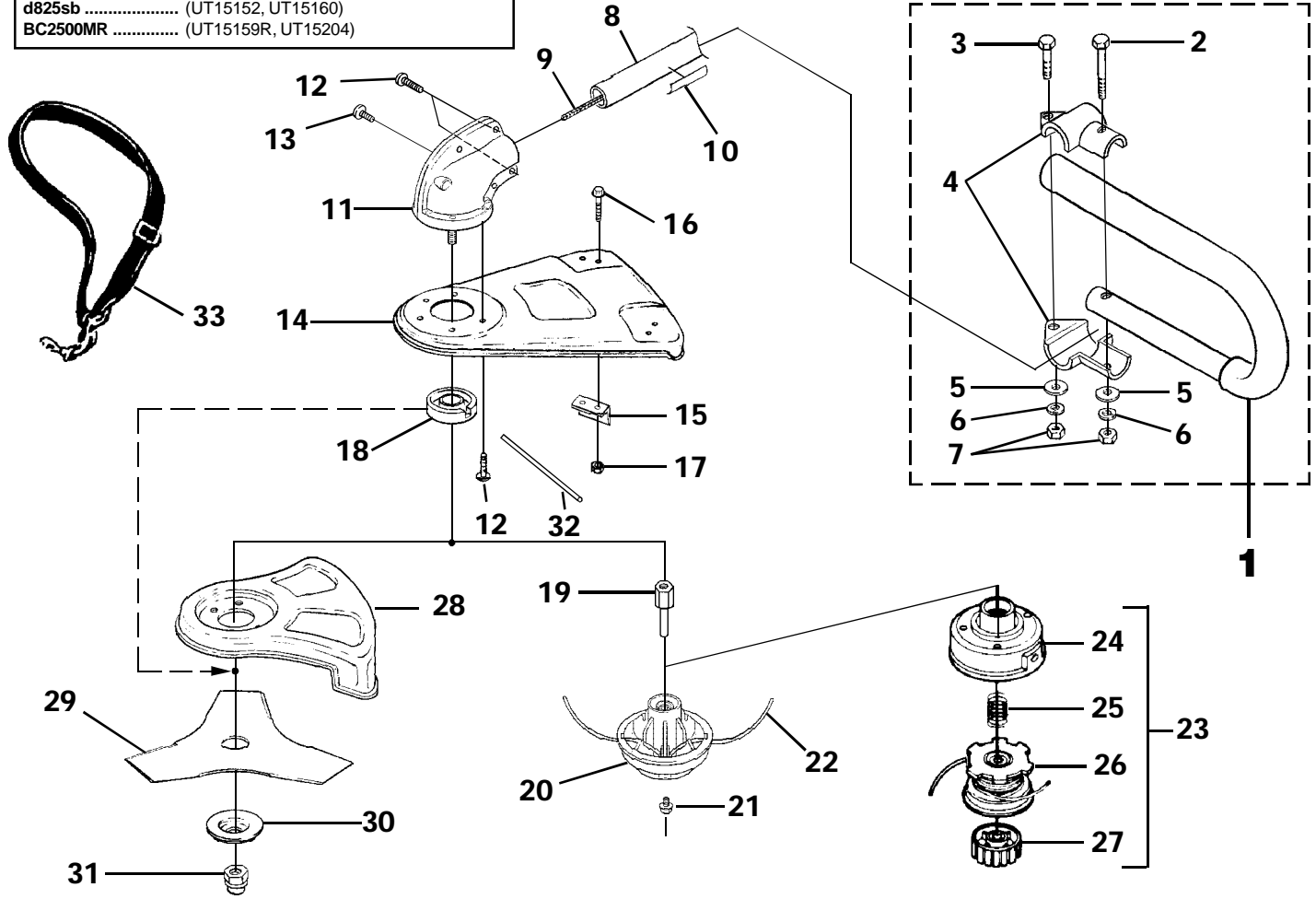

No.	Part No.	Description	Qty.
1	• UP 06534	HANDLE ("J")	1
2	UP 04154	SCREW-Hex Hd. (1/4-20 X 1 1/2")	1
3	UP 04158	SCREW-Hex Hd. (1/4-20 X 1")	1
4	UP 04105	CLAMP-Handle Bar	2
5	UP 04251	WASHER-Flat (1/4")	2
6	UP 03409	WASHER-Lock (1/4")	2
7	UP 03399	NUT-Hex (1/4-20)	2
8	• UP 02969	DRIVESHAFT HOUSING	1
9	UP 04717	DRIVESHAFT-Flexible	1
10	UP 04352	DECAL-Warning	1
11	• UP 06970	GEAR HEAD	1
12	UP 04157	Screw, Taprite Hex Hd. (10-24 x 1/2")	5
13	UP 04155	Screw-Hex Hd. (10-24 x 5/8")	2
14	• A 04683 A	GRASS DEFLECTOR KIT	1
15	UP 04538	BLADE-Cut-Off	1
16	UP 04149	SCREW-Mach. Hex Hd. (10-24 X 3/8")	2
17	UP 03885	NUT-Hex (10-24)	2
18	UP 04126	WASHER-Flanged	1
19	UP 04128	ADAPTER-Shaft	1
20	• DA 09364	STRINGHEAD-Pro-Cut w/line (UT15151, UT15154, UT20722, UT20723, UT15157)	1
21	UP 04102	SCREW-(5/16-18 x 5/8")	1
22	D 09365	LINE-Replacement	1
23	• DA 04591 A	STRINGHEAD-Complete (.095") (UT15152, UT15160, UT15159R, UT15204)	1
24	UP 06567	HOUSING & EYELET (Dual Line)	1
25	UP 06526	SPRING-Compression	1
26	UP 00147	SPOOL & STRING (.095")	1
27	DA 98866 A	RETAINER-Spool (R.H. Thread, Black)	1

No.	Part No.	Description	Qty.
28	UP 04535	BLADE GUARD	1
29	UP 06729	BLADE-Tri-Arc™	1
30	UP 04129	WASHER-Cupped (Lower)	1
31	UP 03492	NUT-Hex (5/16-18) (R.H.)	1
32	UP 04100	TOOL-Holding Pin	1
33	UP 00108	HARNESS	1

Torque Specs			
Item No.	In/Lbs	Nm	Required Loctite
7	90-100	10.2-11.3	
12	15-20	1.7-2.3	
13	40-50	4.5-5.6	
17	30-50	3.4-5.6	
19	100-120	11.3-13.6	
21	40-60	4.5-6.8	
31	100-120	11.3-13.6	

Warranty Flat Rate		
Job	Description	Time/Hr.
FM10	Stringhead Assy.	.2
FN12	Driveshaft (Upper)	.3
FN13	Driveshaft Housing	.4
FN15	Gearhead	.3
FN16	Deflector	.3

03/08/2001

Expand-it™ ..... (UT20710, UT20712,  
UT20735)  
d825ca ..... (UT20711, UT20736)

## BLOWER ATTACHMENT

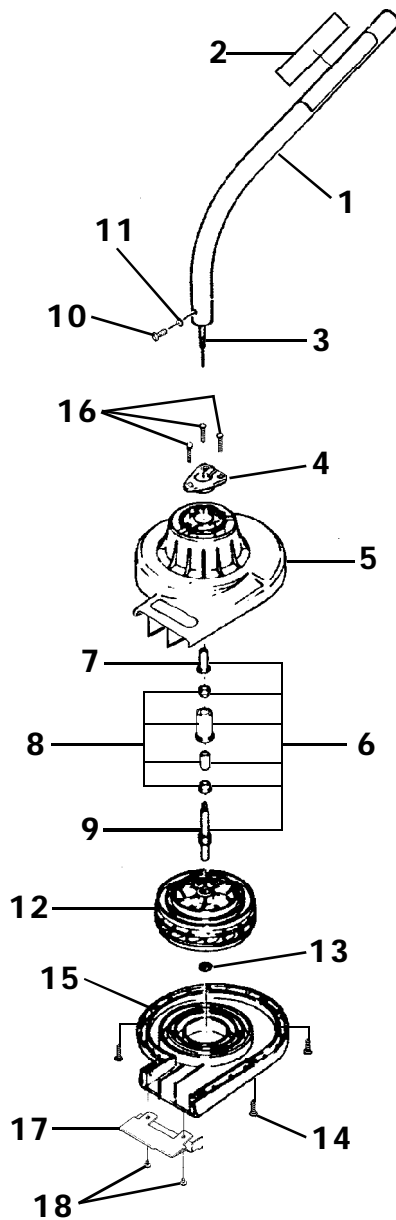

No.	Part No.	Description	Qty.
1	• UP 06790	DRIVESHAFT HOUSING	1
2	UP 04116	DECAL-Warning	1
3	UP 04542	CABLE-Flex	1
4	UP 04142	CLAMP	1
5	UP 06874	UPPER HOUSING	1
6	• UP 06875	BEARING HOUSING	1
7	UP 04713	ADAPTER-Arbor	1
8	UP 06876	BUSING	1
9	UP 04699	SHAFT-Arbor	1
10	UP 04112	SCREW (10-24 x .312")	1
11	UP 041231	WASHER, Lock (#10)	1
12	UP 04714	IMPELLER	1
13	UP 04701	Clip	1
14	UP 04141	SCREW, Pan Hd. (8-16 x .750)	1
15	UP 04697	LOWER HOUSING	1
16	UP 04250	SCREW-Thread Forming (8-16 x 1")	1
17	UP 04145	GUARD-Lower Housing	1
18	GM 01110 8	SCREW (10-16 x 1/4")	1

Item No.	Torque Specs		Required Loctite
	In/Lbs	Nm	
10	25-35	2.8-4.0	
14	35-45	4.0-5.1	
16	35-45	4.0-5.1	
18	5-20	.56-2.3	

Warranty Flat Rate		
Job	Description	Time/Hr.
CD81	Fan, Blower	.4
FN12	Driveshaft	.2
FN13	Driveshaft Hsg.	.3

\* **Note:** Blower must be completely disassembled to install the flex cable.

Expand-it™ ..... (UT20710, UT20712,  
UT20735)  
d825ca ..... (UT20711, UT20736)

# CULTIVATOR ATTACHMENT

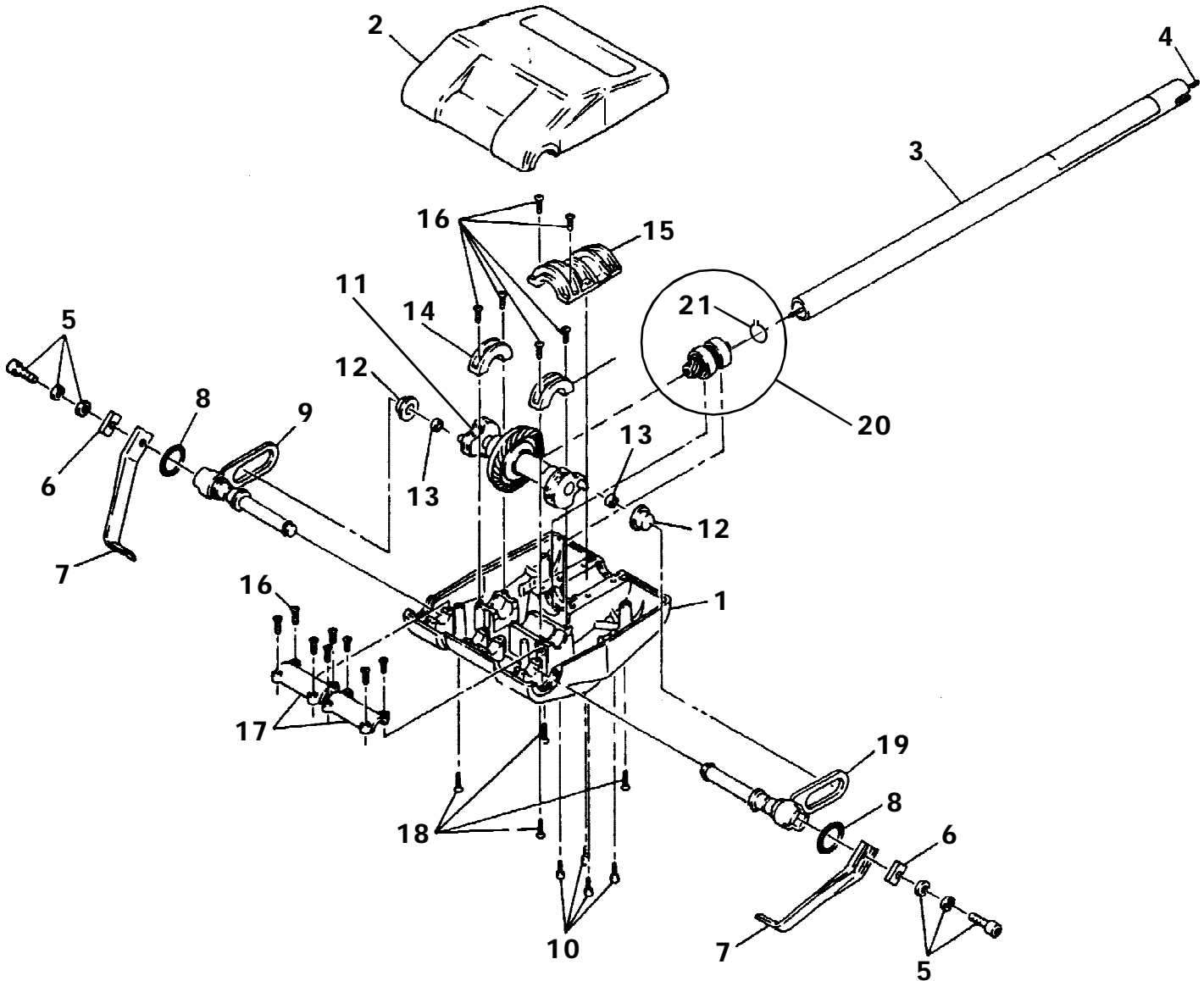

No.	Part No.	Description	Qty.
1	GM 23610 3	LOWER COVER	1
2	A 07934	UPPER HOUSING	1
3	• A 07930	DRIVESHAFT HOUSING	1
4	A 08177	FLEX CABLE	1
5	GM 97030 7	BOLT-Sems (1/4 - 28 x 1")	2
6	GM 23670 6	SUPPORT-Tine	2
7	GM 97690 3	TINE	2
8	GM 23570 1	"O" RING	2
9	A 07868	ROCKER ARM (L.H.)	1
10	82618	SCREW, Thread Form (10-24 x 3/4")	4
11	• A 07867	CRANK ASSY.	1
12	A 07870	FLOATING BUSHING	2
13	GM 23690 3	WASHER	2
14	GM 23610 6	CRANKSHAFT CLAMP	2
15	GM 23610 4	SHAFT CLAMP	1
16	82618	SCREW, Thread Form (10-24 x 3/4")	14
17	GM 23610 5	SHAFT CLAMP	2
18	GM 01130 8	SCREW (8-16 x 1")	4
19	A 07869	ROCKER ARM (R.H.)	1
20	• A 07866	PINNON GEAR & BEARING	1
21	GM 06210 1	SNAP RING	1

Torque Specs			
Item No.	In/Lbs	Nm	Required Loctite
5	90-100	10.2-11.3	
10	40-55	4.5-6.2	Red 262
16	40-55	4.5-6.2	Red 262
18	35-45	4.0-5.1	

Warranty Flat Rate		
Job	Description	Time/Hr.
FN12	Driveshaft	.3
FN13	Driveshaft Hsg.	.3
FN17	Transmission (Rebuild)	.6

Expand-it™ ..... (UT20710, UT20712,  
UT20735)  
d825ca ..... (UT20711, UT20736)

## EDGER ATTACHMENT

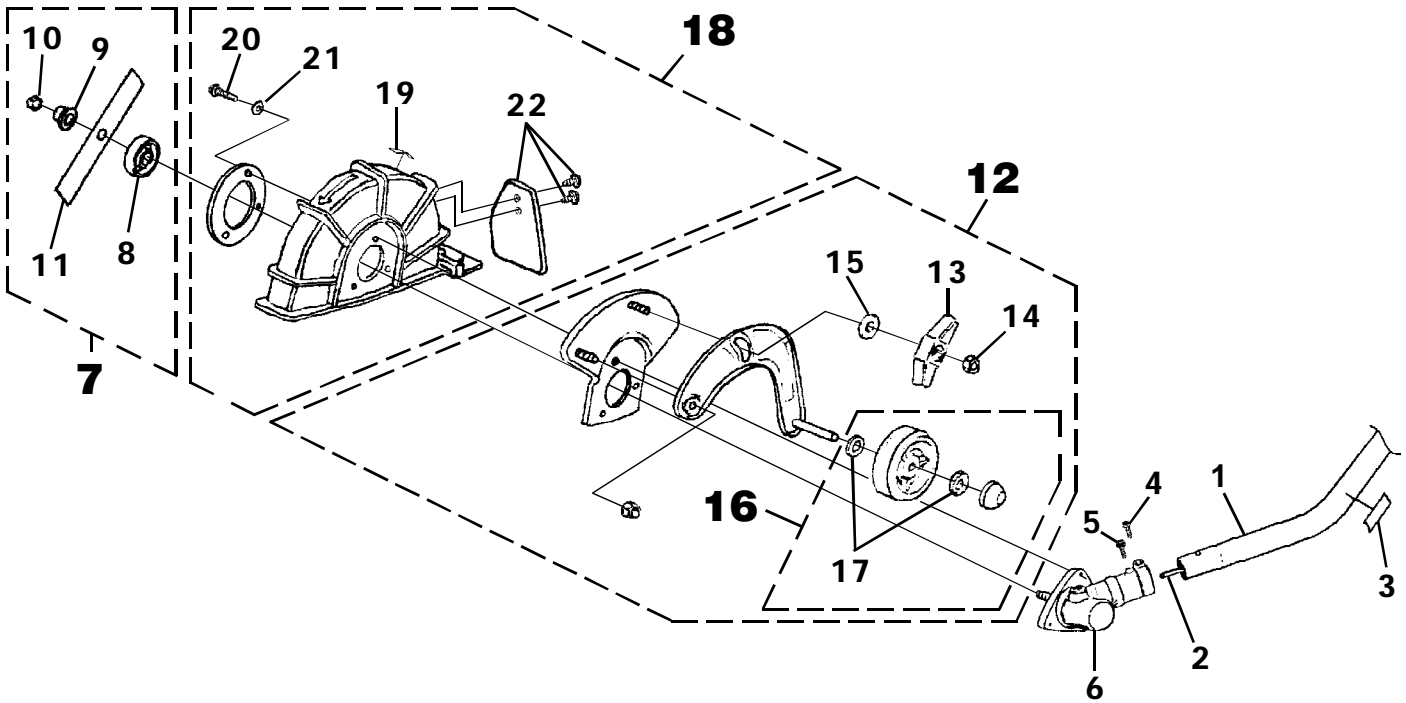

No.	Part No.	Description	Qty.
1	• A 07931	DRIVESHAFT HOUSING	1
2	UP 04369	SHAFT-Flexible	1
3	UP 04116	DECAL-Warning	1
4	UP 05572	SCREW-Cap Socket Hd. (1/4-20 X 7/8")	1
5	UP 04254	SCREW-Sems Hex Hd. (10-24 X 1/2")	1
6	UP 04124	GEAR HEAD	1
7	•UP 06879	BLADE KIT	1
8	UP 04126	WASHER-Flanged	1
9	UP 04129	WASHER-Flanged (Lower)	1
10	UP 04127	NUT-Lock	1
11	D 04359 A	BLADE (2" X 9") (Qty.-2)	1
12	•UP 06881	SUPPORT ARM ASSEMBLY	1
13	UP 04132	KNOB-Adjusting	1
14	UP 03397	NUT-Hex	1
15	UP 04252	WASHER-Flat	1
16	•UP 06882	WHEEL KIT	1
17	UP 04252	WASHER-Flat	2
18	•UP 06738	GUARD KIT	1
19	UP 04532	DECAL-Warning	1
20	UP 04155	SCREW-Hex Hd. (10-24 X 5/8")	3
21	UP 03411	WASHER-Lock (#10)	3
22	UP 06883	FLAP KIT	1

Item No.	Torque Specs		Required Loctite
	In/Lbs	Nm	
4	40-50	4.5-5.6	
5	40-50	4.5-5.6	
10	100-120	11.3-13.6	
20	40-50	4.5-5.6	

Warranty Flat Rate		
Job	Description	Time/Hr.
FN15	..... Gearhead	.4
JE20	..... Wheel Assembly	.3
JE26	..... Wheel/Axle	.3
JR11	..... Blade Cutter	.3
FN12	..... Driveshaft	.3
FN13	..... Driveshaft Hsg.	.3
FN16	..... Bladeguard	.4



Expand-it™ ..... (UT20710, UT20712,  
UT20735)  
d825ca ..... (UT20711, UT20736)

# BRUSHCUTTER ATTACHMENT

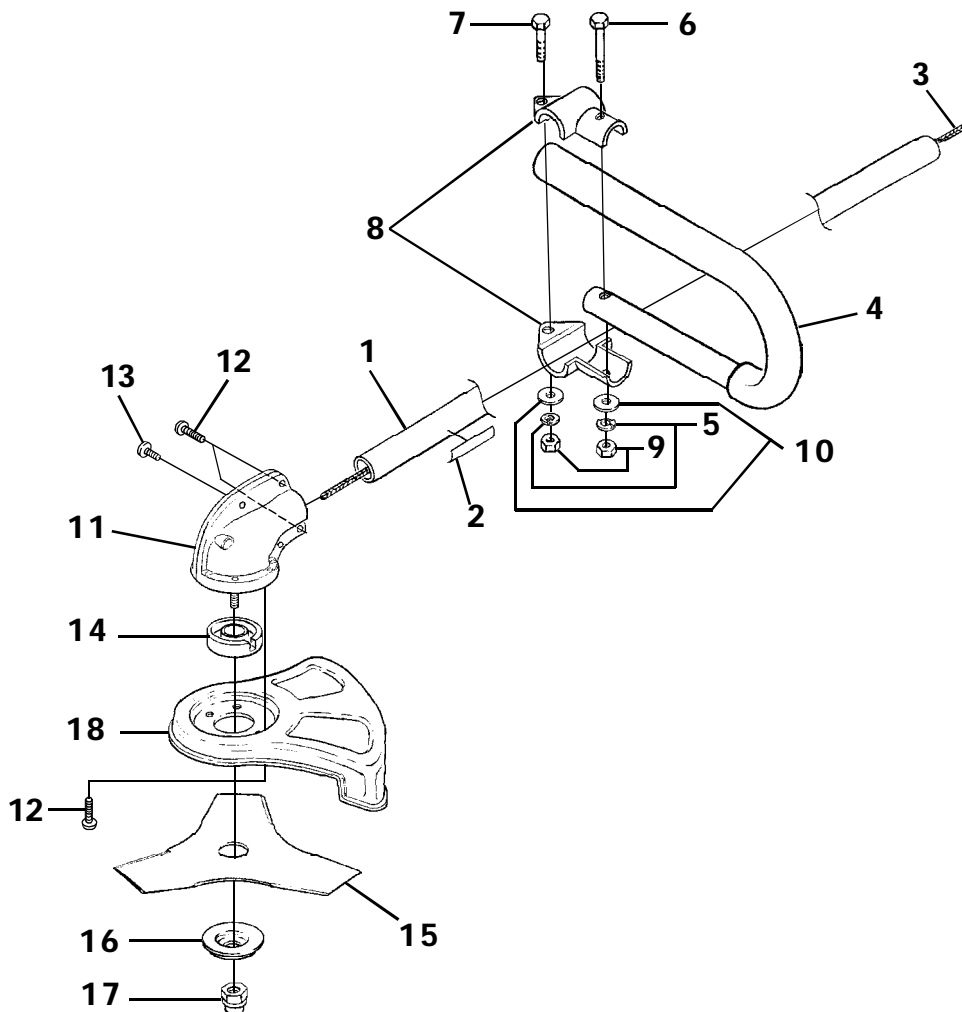

No.	Part No.	Description	Qty.
1	• A 07904	DRIVESHAFT HOUSING	1
2	UP 04116	DECAL-Warning	1
3	UP 04369	SHAFT-Flexible	1
4	• UP 06534	FRONT HANDLE ("J")	1
5	UP 03409	WASHER-Lock (1/4")	2
6	UP 04154	SCREW-Hex Hd. (1/4-20 X 1/2")	1
7	UP 04158	SCREW-Hex Hd. (1/4-20 X 1")	1
8	UP 04105	CLAMP-Handle Bar	1
9	UP 03399	NUT-Hex (1/4-20)	2
10	UP 04251	WASHER-Flat (1/4")	2
11	• UP 06970	GEAR HEAD	1
12	UP 04157	Screw, Taptite Hex Hd. (10-24 x 1/2")	5
13	UP 04155	Screw-Hex Hd. (10-24 x 5/8")	2
14	UP 04126	WASHER-Flanged	1
15	D 98717 C	BLADE-Tri-Arc™ (8")	1
16	UP 04129	WASHER-Cupped	1
17	UP 03492	NUT-Hex Locking (R.H.)	1
18	UP 04535	BLADE GUARD	1

Item No.	Torque Specs		Required Loctite
	In/Lbs	Nm	
9	90-100	10.2-11.3	
12	15-20	1.7-2.3	
13	40-50	4.5-5.6	
17	100-120	11.3-13.6	

Warranty Flat Rate		
Job	Description	Time/Hr.
FN12	Driveshaft	.3
FN15	Gearhead	.3
FN16	Blade Guard	.3
FD20	Front Handle	.2

# ACCESSORIES

GREASE, MULTI-PURPOSE .....	18453	STRINGHEAD-Complete - E-Z Line™ .....	DA 04591 A (.095 Line) (Right Hand Thread) (Black Retainer)
MODULE AIR GAP SHIM .....	PS 24306	REPLACEMENT STRING - E-Z Line™ (3 lb. Box) .....	03959 04 (.095" Dia.)
GRASS ANTI-WRAP KIT .....	A 04191	STRINGHEAD-Complete-Pro-Cut™ Fixed Line Head .....	DA 09364 (.105" Dia.)
STARTER ROPE (250 Ft. Reel) .....	98052 A	REPLACEMENT DuraLine™ (.105" Dia.) .....	D 09365 (Cartridges for Pro-Cut™ Fixed Line Head)
TORX BIT (T25) .....	UP 06544 (For Clutch Drums)	SAFETY GOGGLES .....	A 06933
TORX BIT (T27) .....	UP 07160	DUST MASK .....	UP 03036
IGNITION TEST SPARK PLUG .....	JA 31316 4	COMFORT STRAP .....	UP 00108
RUBBER TUBING (10 Ft.) .....	UP 05860		
STRINGHEAD-Complete - E-Z Line™ .....	DA 03001 A (.080 Line) (Right Hand Thread) (Black Retainer)	<b>FOR USE ON BRUSHCUTTER UNITS ONLY</b>	
REPLACEMENT STRING - E-Z Line™ (3 lb. Box) .....	98011 06 (.080" Dia.)	TRI-ARC™ BLADE .....	D 98717 C