

REVISION 3
PART NO. 17068
Printed in U.S.A.
Price .35¢

parts list

HOMELITE®

VI Super 2

VI Super 2 SL

Chain Saws



HOMELITE **TEXTRON**

Homelite Division of Textron Inc

VI SUPER 2, VI SUPER 2 SL

ACCESSORIES

GASKET- Oil pump body	69596
KIT- Spark arrestor (for A-69253-1 Muffler)	A-69586-B
Includes:	
SCREW- Self tapping (#6 x 1/4) (3)	80328
ROPE- Starter #4 (250 ft.)	68848
SAFE-T-TIP® (standard)	A-70776-A
Includes:	
SCREW (8-32 x .437)	93695
TUBING- Rubber (10 ft.)	70309-99
TUBING- Rubber (10 ft.)	70310-99
CARRY CASE- Black	94216
KIT- Sprocket bar repair	A-70239-C
Includes:	
BEARING- Guide Bar	70737
RIVET- Flat cks. hd.	96623

TOOLS

PULLER- Magneto rotor	A-24747-A
Includes	
BOLT- 5/16 - 18 x 1 3/4	80288
NUT- Hex 5/16 - 18 (2)	81198
WRENCH- Spanner (clutch)	A-93791
Includes	
PIN	23717-A
WRENCH- Flat (for guide bar nut) (Opt.)	24814
DRIVER- Check valve (for HDC-67 carb.)	24972
PLIERS- Tru-Arc	17188

VI SUPER 2, VI SUPER 2 SL
FIGURE 1

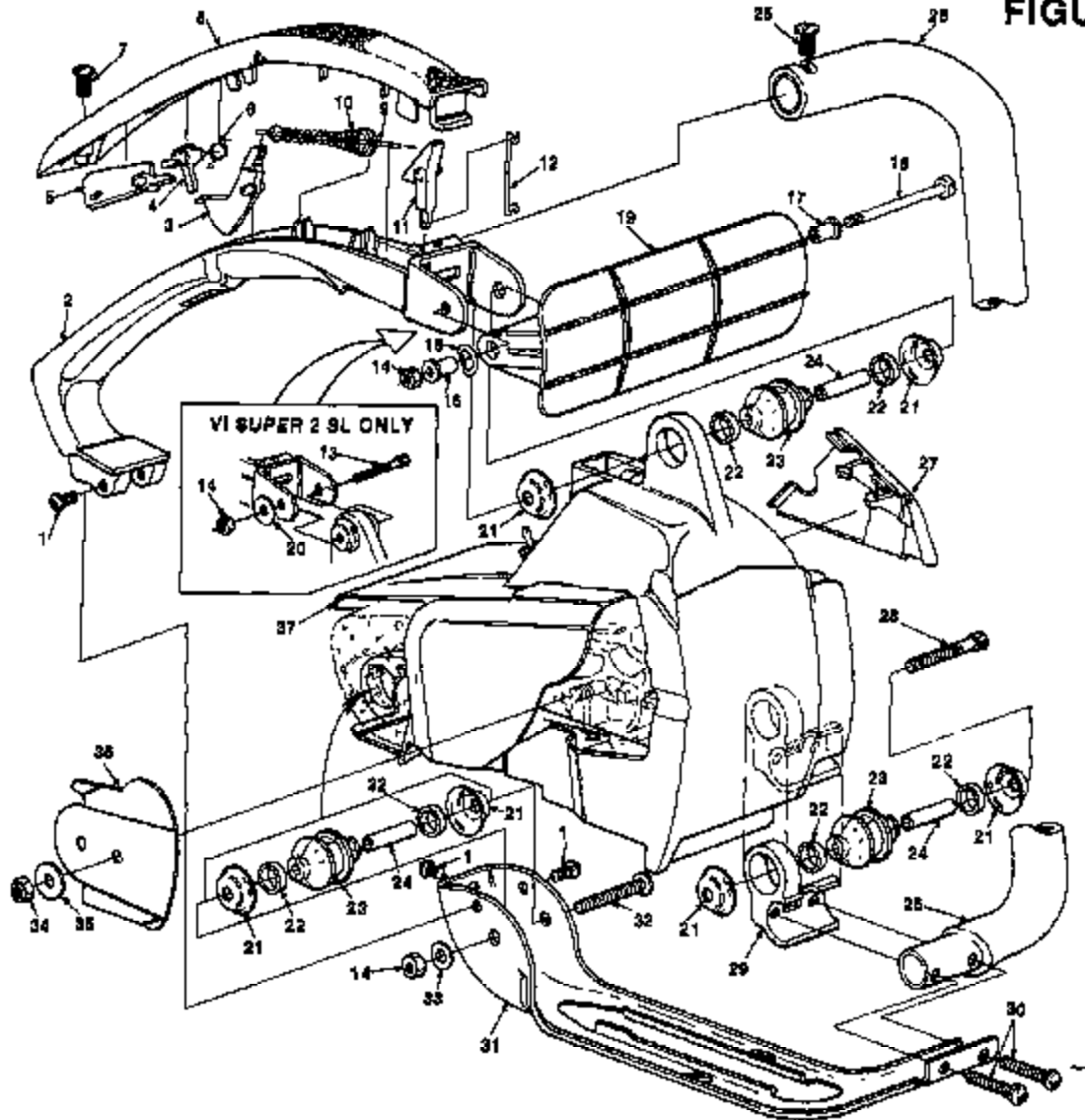

NO.	DESCRIPTION	PART NO	QTY.	NO.	DESCRIPTION	PART NO.	QTY.
1	SCREW- Pan hd (6-32 x 3/8)	80677	3	23	ISOLATOR- Vibration	70485-A	3
2	HANDLE- Throttle (see note 1)	70568-2A	1	24	SPACER- Isolator	70433	3
3	TRIGGER	70519	1	25	SCREW- Pan washer hd (10-32 x 5/8)	82239	1
4	STOP- Throttle safety	70503	1	26	HANDLE BAR	A-70504	1
5	LEVER- Throttle safety	70594	1	27	COVER- Air filter	70571	1
6	SPRING- Torsion	70691	1	28	SCREW- Cap hex soc (10-32 x 1 3/4)	82310	1
7	SCREW- Pan hd (#10-32 x 5/8)	82239	1	29	BRACKET- Isolator mtg	70558-2A	1
8	COVER- Handle	70826	1	30	SCREW- Hex hd (10-32 x 1 3/16)	80841	2
9	ROD- Throttle	A-70814	1	31	SPACE- Handle	70654-1	1
10	SPRING- Throttle rod	69249	1	32	SCREW- Pan hd (10-32 x 1 3/4")	82317	1
11	LEVER- Throttle	89107	1	33	WASHER- Flat (10)	84008	1
12	ROD- Throttle	70812	1	34	NUT- Guide bar (1/4-28)	81055-2	1
13	SCREW- Cap hex soc hd (10-32 x 1 3/4) (see note 2)	82310	1	35	WASHER- Flat	69309-A	1
14	NUT- Hex (10-32)	81206	2	36	PLATE- Guide bar	69360-1	1
15	WASHER	85813	1	37	HOUSING- Engine (see fig 2 for breakdown)	A-70682-C	1
16	BUSHING	95814	1				
17	BUSHING	95815	1				
18	SCREW- Mach pan hd	95869	1				
19	GUARD- Hand	85715	1				
20	WASHER- Flat	70832	1				
21	WASHER- Isolator	70440-A	6				
22	RING- Isolator	70432-A	6				

NOTE 1: Units prior to Lot #1090 and chain brake units only.

NOTE 2: For units with steel hand guard 70802-1 require 70728 ball-bearing washer and 70746 spacer, and screw 62321.

VI SUPER 2, VI SUPER 2 SL FIGURE 2

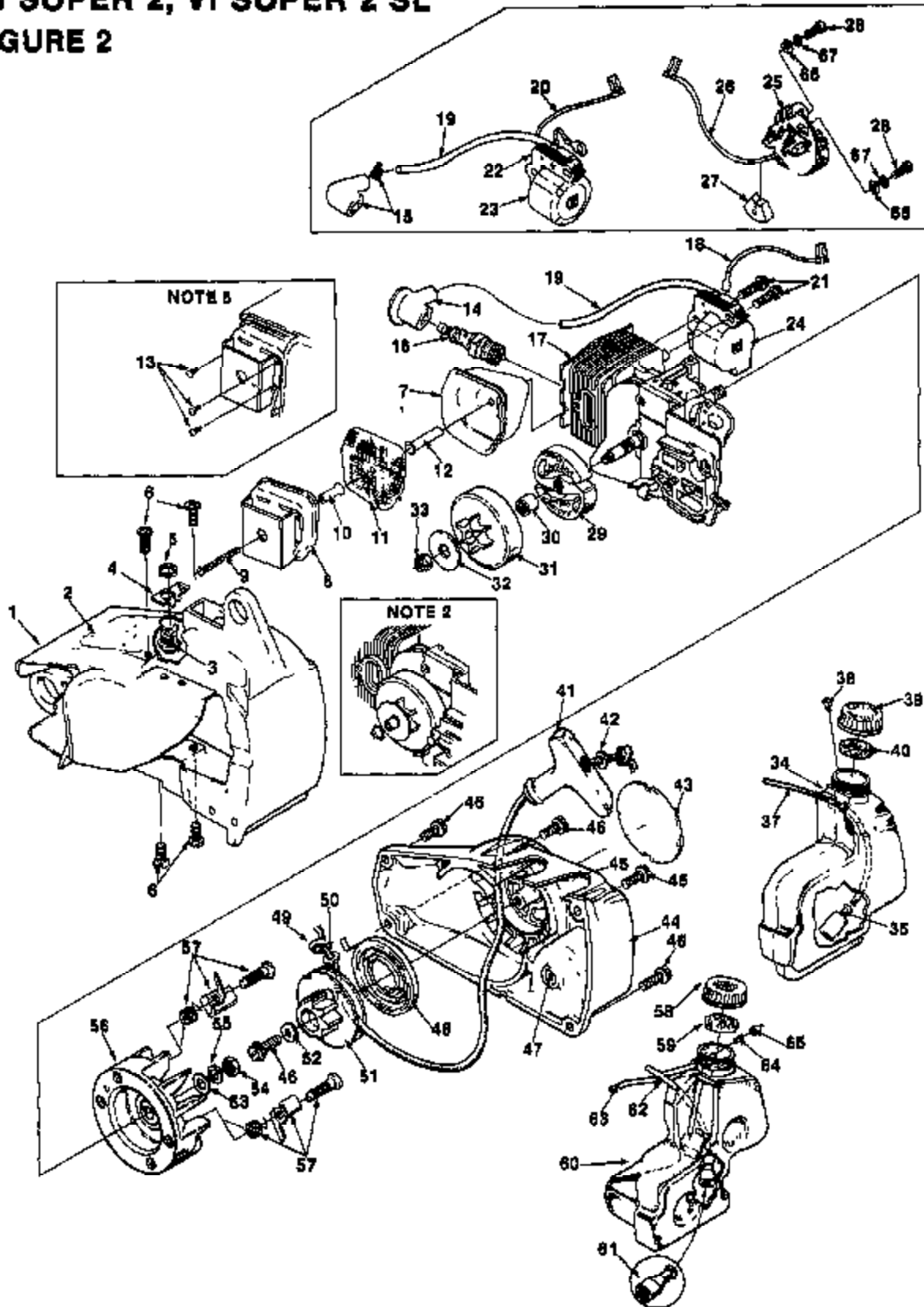

VI SUPER 2, VI SUPER 2 SL FIGURE 2

NO.	DESCRIPTION	PART NO.	QTY.	NO.	DESCRIPTION	PART NO.	QTY.
1	HOUSING- Engine Includes:	A-70662-C	1	44	HOUSING- Rewind starter Includes:	A-70663	1
2	PLATE- Instructions	70635	1	45	FILTER- Fuel tank valve	69443	1
3	SWITCH- Stop (grounding) Includes:	A-83938	1	46	SCREW- Hex washer hd. (10-32 x 5/8)	80572	4
4	PLATE- On-Off	70834	1	47	NUT- Center locking hex (#10-32)	81206	1
5	NUT- Hex	72064-A	1	48	SPRING- Rewind	69217	1
6	SCREW- Pan hd. 10-24 x 1/2	96620	4	49	ROPE- Starter (#4, 34" long) Includes:	A-93874-A	1
7	MUFFLER Includes:	A-94061-B	1	50	WASHER- Nylon	93862	1
8	CAP- Muffler	A-85428	1	51	PULLEY- Starter	69156-A	1
9	SCREW- (10-24 x 1 3/4) SPARK ARRESTOR Includes:	82320	1	52	PULLEY- Starter (alternate)	94562-A	1
10	SPACER	93989	1	53	WASHER- Flat	63808-1	1
11	SCREEN- Spark arrester	D-89991	1	54	WASHER- Flat	84085-1	1
12	SPACER	83980	1	54	NUT- Hex	81117	1
13	SCREW- #4 x .250 (note 6)	82342	3	56	WASHER- Lock	83002	1
14	TERMINAL- Spark plug (solid state) (serviced with item #15)			56	ROTOR & STARTER PAWL (Solid State)	A-95714	1
15	TERMINAL- Spark plug (point ignition)	A-88055	1		ROTOR & STARTER PAWL (Point Ignition—)	A-69297-B	1
16	SPARK PLUG— Champion DJ-7J	88616-S	1		Includes:		
17	See Figure 3			57	KIT- Starter pawl (see note 4)	A-70285-C	2
18	LEAD- Ground (Solid State)	A-84721	1	58	CAP- Oil Includes:	A-70893-B	1
19	LEAD- High tension (see note 1)	89326	1	59	GASKET- Fuel filler cap (see note 3)	34838-A	1
20	LEAD- Ground (point ignition)	A-95051	1	60	TANK- Oil Includes:	A-70563-A	1
21	SCREW- Hex w/washer (8-32 x 3/4)	82248	2	61	FILTER- Oil	A-88593	1
22	CORE- Coil (point ignition)	88324	1	62	TUBING- Rubber 6"	70308-24	1
23	COIL- Ignition (point ignition) RETAINER- Coil (not shown) (point ignition)	69323	1	63	LINE- Pressure Includes:	A-69358-B	1
24	MODULE- Ignition (Solid State) (note 6)	94711	1	64	CONNECTOR- Oil line	89659-B	1
26	POINT SET- Breaker (point ignition) Includes:	A-89336	1	65	VALVE- Check (Duckbill)	88451	1
26	LEAD- Electrical (point ignition)	70249	1	66	WASHER- Flat (Point Ignition)	84025	2
27	SEAL- Lead (point ignition)	69247	1	67	WASHER- Lock (Point Ignition)	83060	2
28	SCREW- Fil. hd. (6-32 x 3/8) (point ignition)	86026	2				
29	CLUTCH "S" (see note 2)	A-70351-A	1				
30	BEARING- Clutch	68512	1				
31	SPROCKET & DRUM 3/8" 6-tooth	A-70221-C	1				
32	WASHER- Thrust (clutch)	85289	1				
33	NUT- Locking 5/16-24 (see note 2)	81112	1				
34	TANK- Fuel	A-70582-A	1				
35	FILTER- Fuel	86689	1				
37	TUBING- Rubber 9 1/2"	70310-38	1				
38	VALVE- Check (Duckbill)	69451	1				
39	CAP- Fuel (red) Includes:	A-70694-B	1				
40	GASKET- Filler cap (see note 3)	94838-A	1				
41	GRIP- Starter rope	70211	1				
42	WASHER- Flat	84025	1				
43	DECAL (VI Super 2)	70800	1				
	DECAL (VI Super 2SL)	70798	1				

NOTE 1: For solid state ignition cut wire to 8 1/2'.

NOTE 2: Crankshafts without threaded clutch end require retaining ring 93972.

NOTE 3: Use 70826 Gasket in A-70883 and A-70884 external thread caps. Use 69866 Gasket for caps with internal threads.

NOTE 4: Replacement starter pawl kit, item #57 includes an oversized pin. Paint, stamp or mark to identify oversized pin can be installed lightly only once. If oversized pin is removed, the entire rotor assembly must be replaced.

NOTE 5: Units with separate shield requires index #13 screw. All new muffler cap A-95428 includes a shield welded to cap.

NOTE 6: Module 94711 includes items 16 and 19.

VI SUPER 2, VI SUPER 2 SL FIGURE 3

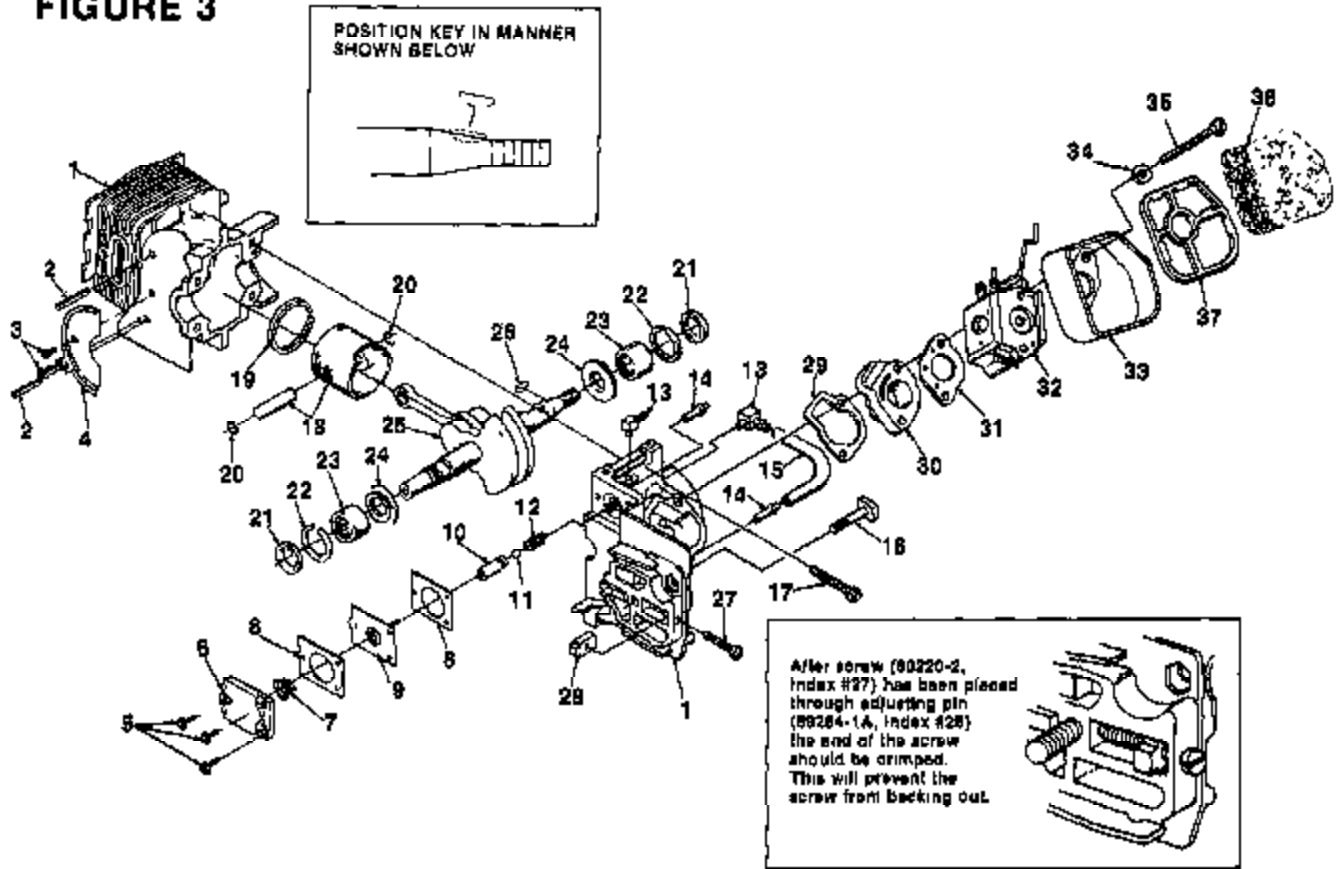

NO.	DESCRIPTION	PART NO.	QTY.	NO.	DESCRIPTION	PART NO.	QTY.
1	CRANKCASE & CYLINDER (Solid State) VI Super 2	A-95072	1	16	PISTON & PIN	A-70224-A	1
	CRANKCASE & CYLINDER (Point Ignition)	A-70226	1	18	PISTON RING	70205	1
	CRANKCASE & CYLINDER (Solid State) VI Super 2SL	A-95073	1	20	RING- Piston retaining	65261	2
	CRANKCASE & CYLINDER (Point Ignition)	A-70897	1	21	SEAL	94838	2
	Includes			22	SPACER- Seal	69407	2
2	PIN- Roll (VI Super 2SL only)	70763	2	23	BEARING- Needle	12630	2
3	SCREW- Tapping pan (VI Super 2SL only)	93832	2	24	WASHER- Thrust	69083-B	2
4	PLATE- Retaining (VI Super 2SL only)	70724	1	25	CRANKSHAFT- (Solid State--)	A-96384	1
5	SCREW- Pan hd (6-32 x 3/8)	80571	3		CRANKSHAFT- (Point Ignition)	A-96385	1
6	COVER- Oil pump	89224-1C	1		Includes		
7	SPRING- Oil pump	69447	1	26	NUT (not shown)	81112	1
8	GASKET- Oil pump	69244-1	2	27	KEY- Magneto (see insert)	69250	1
9	PLUNGER- Oil pump	A-12358-B	1	28	SCREW- Adjusting fil hd (8-32 x 1)	80220-2	1
10	BODY- Oil pump	69343-1	1	29	PIN- Adjusting	89254-1A	1
11	BALL- Check valve	80051	1	30	GASKET- Intake manifold	69143	1
12	SPRING- Check valve	66570	1	31	MANIFOLD- Intake	A-89373-A	1
13	FITTING- Oil line	70204	2	32	GASKET- Carburetor	65016	1
14	FITTING- Tube	69323	2	33	CARBURETOR- HDC 87	A-88621	1
15	LINE- Oil	70161	1	34	CUP- Air filter	70057	1
16	BOLT- Guide bar (8-32 x 1)	88195	1	35	WASHER- Lock #10	83008-1	2
17	SCREW- Sems hex hd (8-32 x 1)	88044	4	36	SCREW- Hex hd (10-32 x 2 1/4)	80481	2
				37	FILTER ELEMENT- Air	70586	1
					RETAINER- Air filter	70556	1

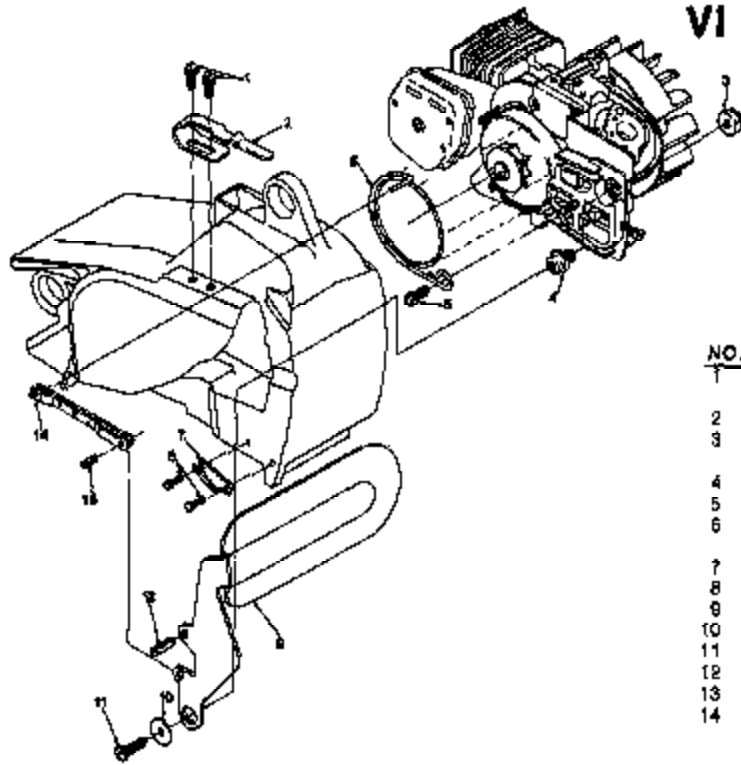

**VI SUPER 2, VI SUPER 2 SL
FIGURE 4**

**VI SUPER 2 SL
CHAIN BRAKE &
HAND GUARD**

NO.	DESCRIPTION	PART NO.	QTY.
1	SCREW- Hex hd w/washer 6-32 x 3/8	88028	2
2	CLIP- Retaining	70732	1
3	NUT- Hex 3/8-24	81192	1
	Power head (see figure 3 for breakdown)		
4	POST- Chain brake	70836	1
5	BAND- Brake	70637	1
6	SCREW- Hex (10-24 x 1/2) w/washer	88042	1
7	STOP- Chain	93649	1
8	SCREW- (8-32 x 500)	88042	2
9	HAND GUARD	A-84000	1
10	WASHER- Flat	70632	1
11	SCREW- (10-32 x 1/2)	82188	1
12	PIN- Roll (3/16 x 9/16)	93089	1
13	PIN- Spring (18-1/4)	57721	1
14	LINK- Pivot	A-70787	1

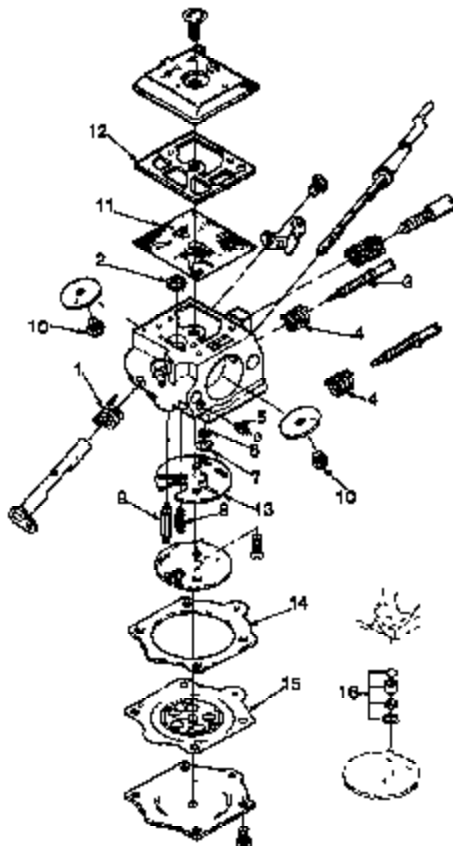

**CARBURETOR
A-96621
HDC-67**

- 94056 Repair Kit (Includes 1-15)
- 94701 Gasket/Diaphragm kit (Includes 11-15)
- 93910-A Check valve repair kit (#16)
- 64229 Inlet Needle (#9)

Homelite Division of Textron Inc.
14401 CAROWINDS BOULEVARD
CHARLOTTE, NORTH CAROLINA 28217

HOMELITE **TEXTRON**
Homelite Division of Textron Inc