

324Rx

324Lx

324LDx

Spare parts

Ersatzteile

Pièces détachées

Reserve onderdelen

Repuestos

Reservdelar

RECOMMENDED PARTS, ACCESSORIES, LUBRICANTS

324Lx TRIMMER

	<u>Item</u>	<u>Part Number</u>	<u>Description</u>
Normal Maintenance Parts	Air Filter	531 00 86-93	
	Air Filter Cover	537 31 14-01	
	Fuel Filter	531 00 87-09	
	Fuel Cap	531 00 87-08	
	Oil Cap	531 00 86-10	
	Ignition Module	531 00 87-14	
	Spark Plug	531 00 86-14	
	Start/Stop Switch	503 71 82-01	
	Starter Assy.	531 00 86-41	
	Starter Pawl	531 00 86-47	
	Starter Pully	531 00 86-43	
	Starter Pully Spring	531 00 86-45	
	Cylinder Cover	531 00 87-28	
	Cylinder Filter	531 00 87-25	
	Handle, Loop	503 87 19-03	
	Grass Shield	503 97 71-01	
Line Cutter	503 79 88-01		
Gear Head	537 19 92-01		
	<u>Item</u>	<u>Part Number</u>	<u>Description</u>
Trimmer Accessories	Trimmer Line	639 00 50-12	.080" Titanium Trimmer Line, 1/2 lb.
		639 00 50-02	.095" Titanium Trimmer Line, 1/2 lb.
		639 00 50-03	.105" Titanium Trimmer Line, 1/2 lb.
	Trimmer Head	531 30 01-94	T35 Trimmer Head
		531 30 03-64	T35 Replacement Spool
	Brush Cutter Blade	531 30 02-34	255-4 Brush Cutter Blade (When Used With a Barrier Bar Kit ONLY)
Barrier Bar Kit	537 04 85-02	Barrier Bar Kit - 300 Series Trimmers	
	<u>Item</u>	<u>Part Number</u>	<u>Description</u>
Lubricants	4 Stroke Engine oil	531 00 92-71	Four Stroke Engine Oil (SAE 10W-40) - 1 Bottle per Trimmer
	<u>Item</u>	<u>Part Number</u>	<u>Description</u>
Protective Apparel	Protective Glasses	531 30 00-11	Xtreme Protective Glasses
	Protective Gloves	531 30 02-70	Master Grip Gloves, Medium
		531 30 02-71	Master Grip Gloves, Large
		531 30 02-72	Master Grip Gloves, X-Large
	Hearing Protectors	505 66 53-04	Husqvarna Headband Hearing Protectors
		505 66 53-78	Husqvarna Landscaper Radio Hearing Protectors - Digital FM

A

*compl 537 19 92-02

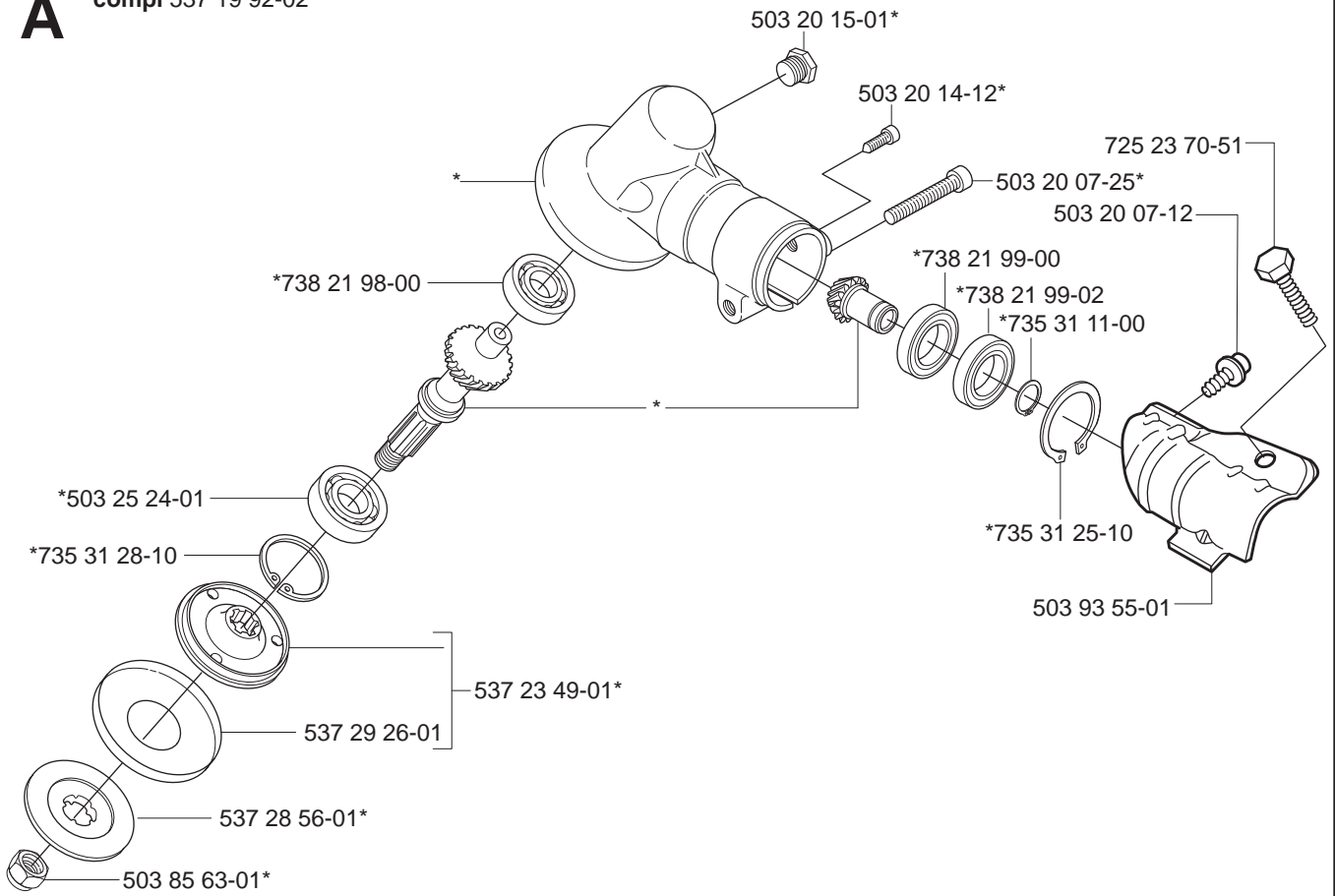
**B**

324Lx

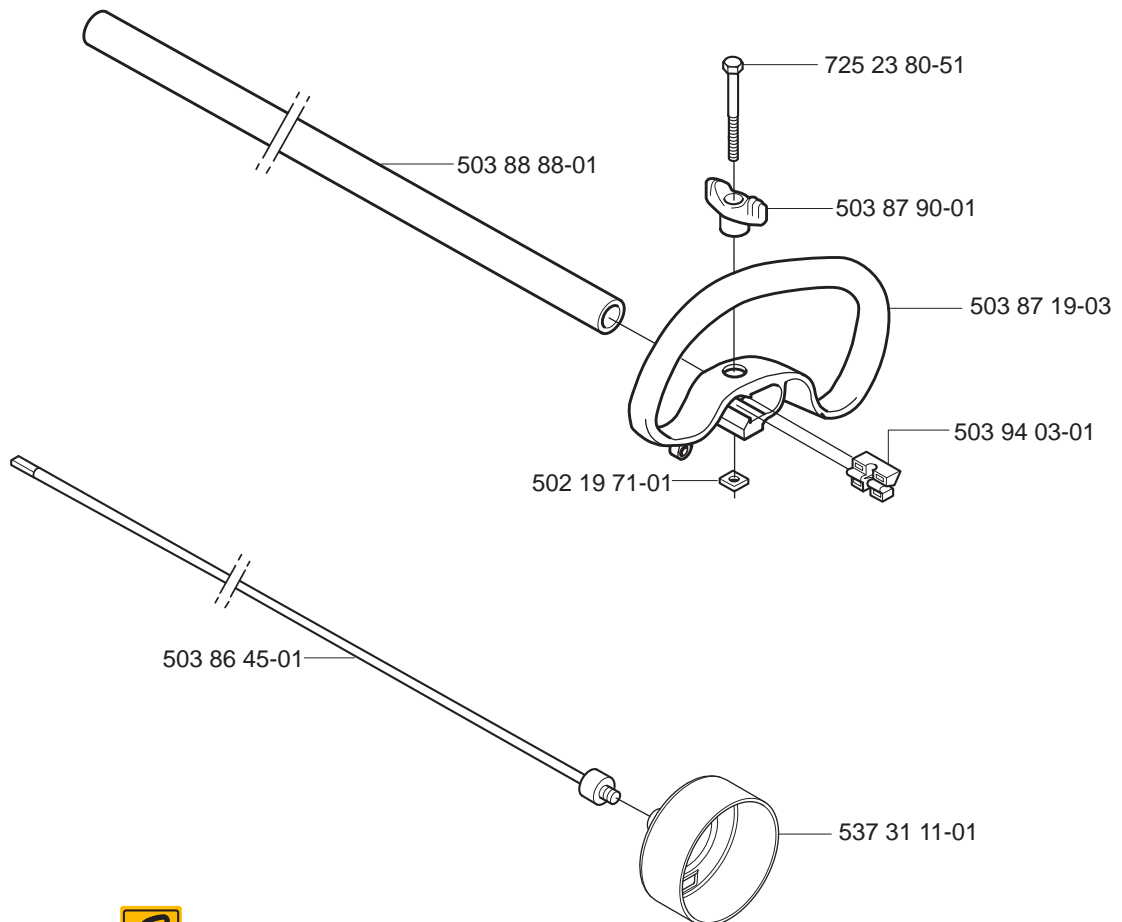

537 02 76-01 503 79 56-01 (324Lx)

C 324LDx

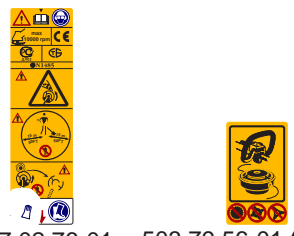
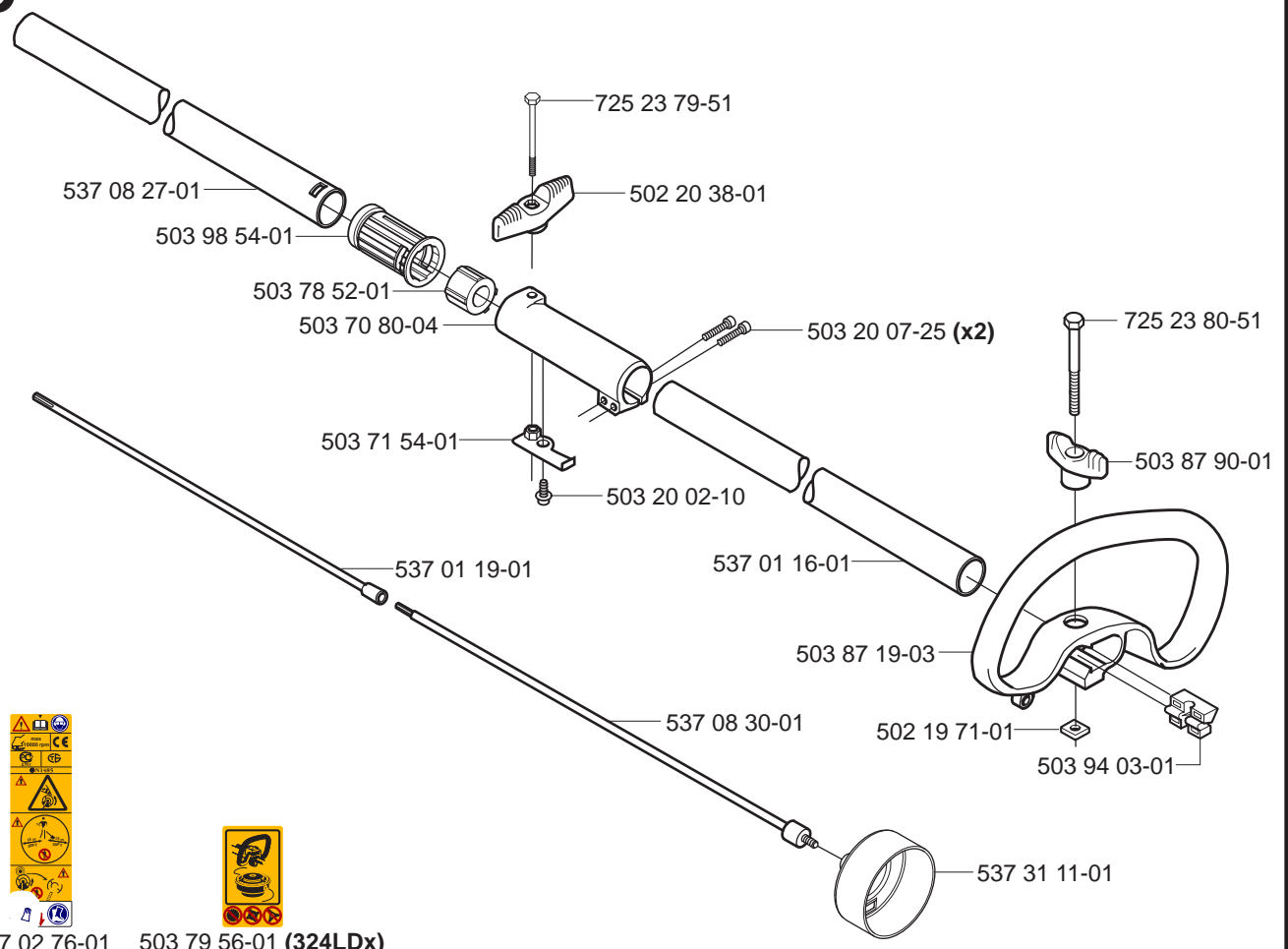

537 02 76-01 503 79 56-01 (324LDx)

D 324Rx
**compl 503 72 43-09

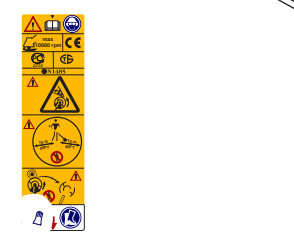
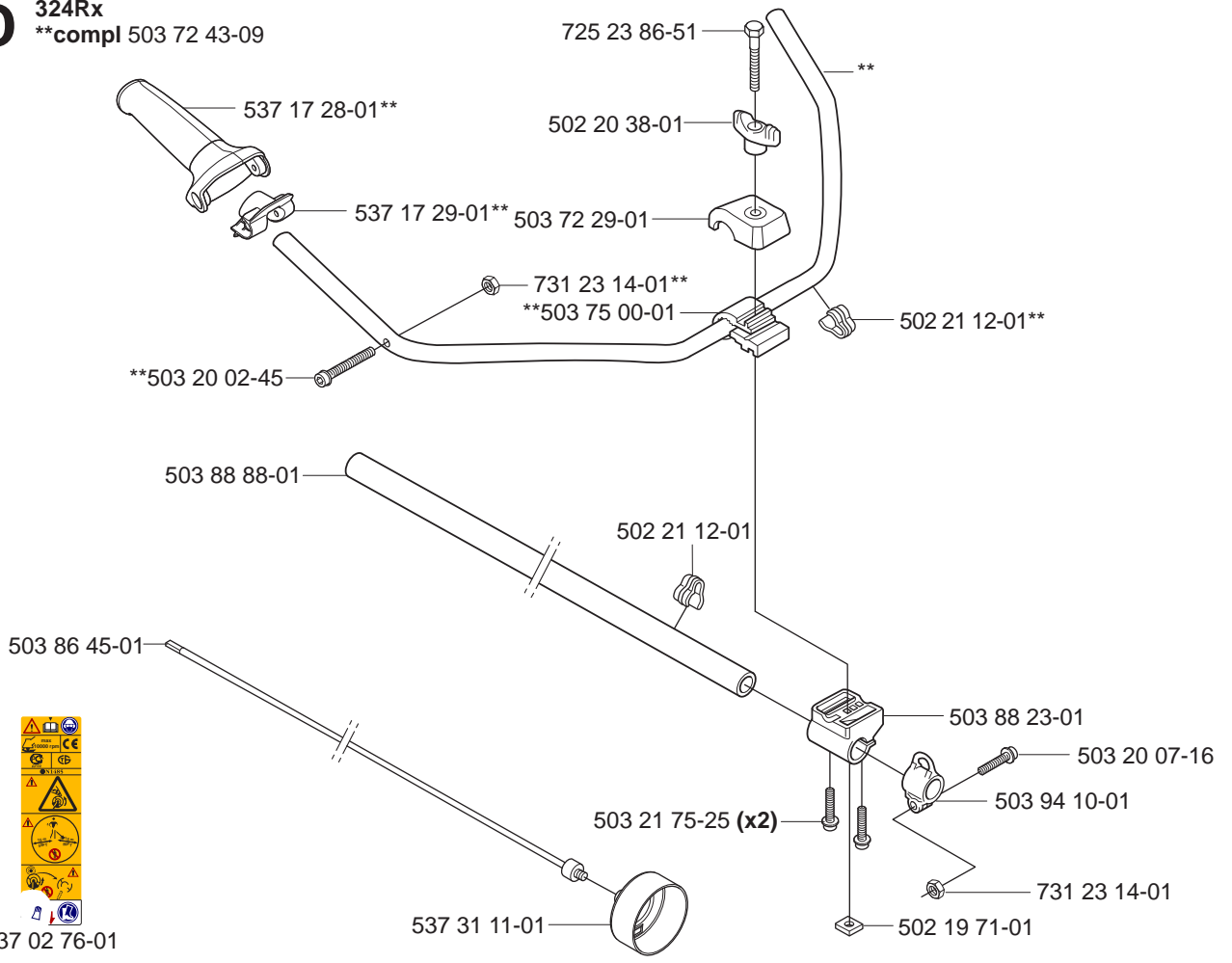

537 02 76-01

E 324Lx *compl 503 85 29-06
324LDx

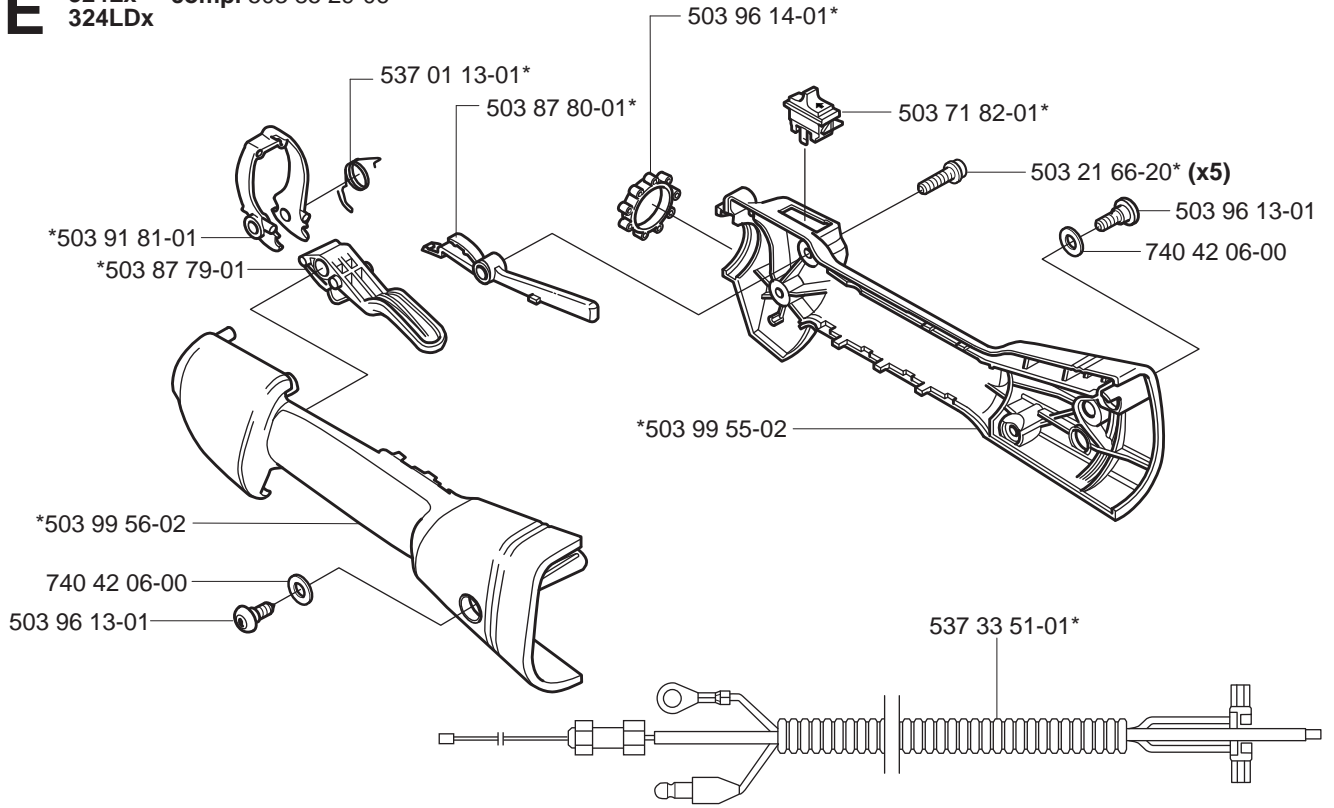

F 324Rx
*compl 537 18 35-01

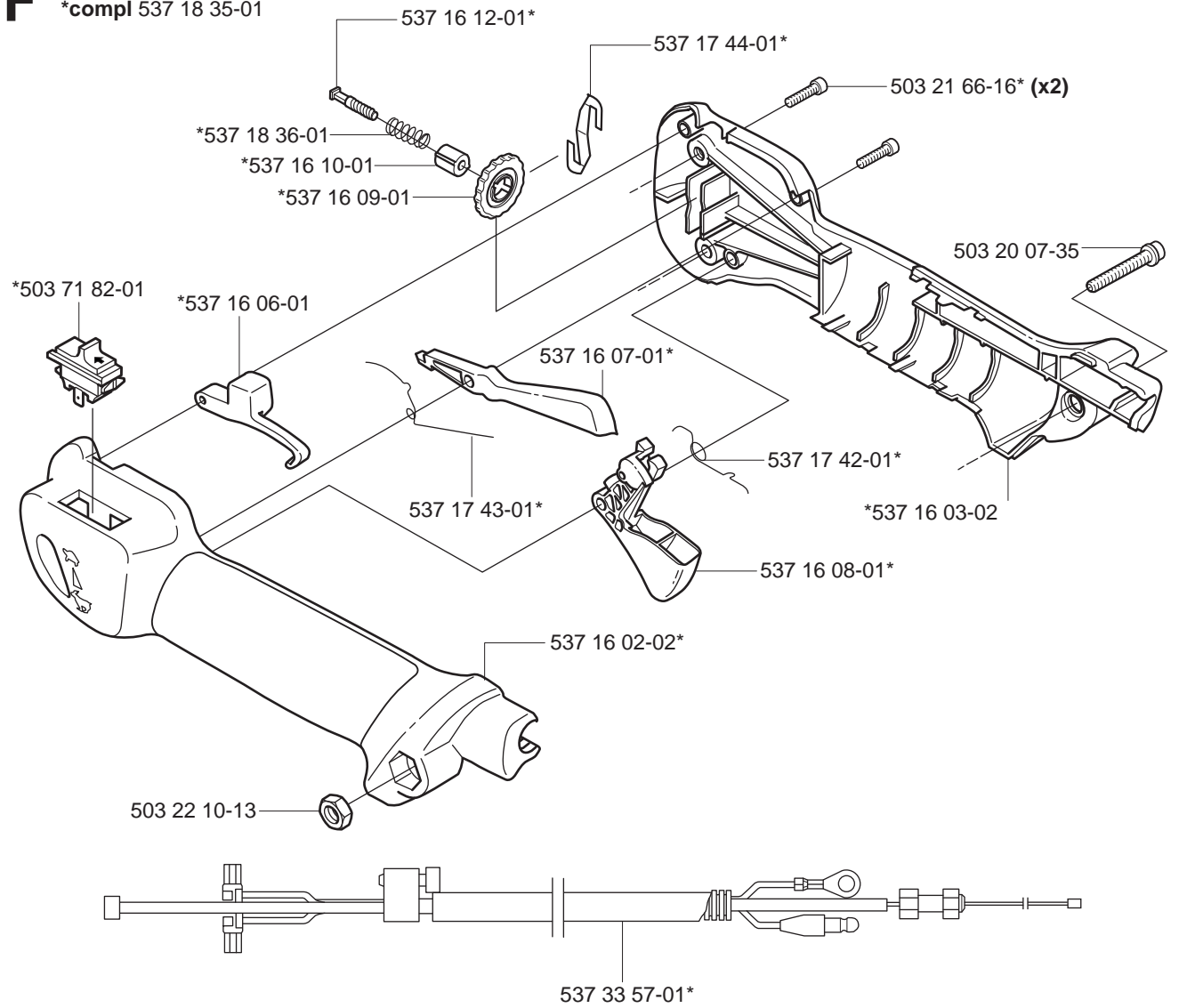

G

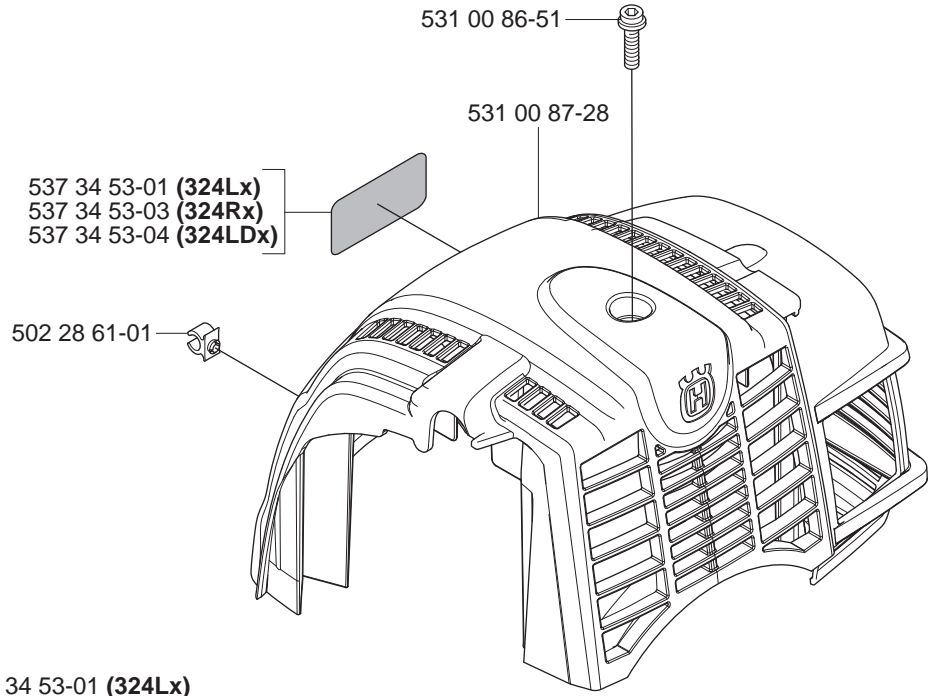

537 34 53-01 (324Lx)



537 34 53-03 (324Rx)



537 34 53-04 (324LDx)

H

*compl 531 00 86-41

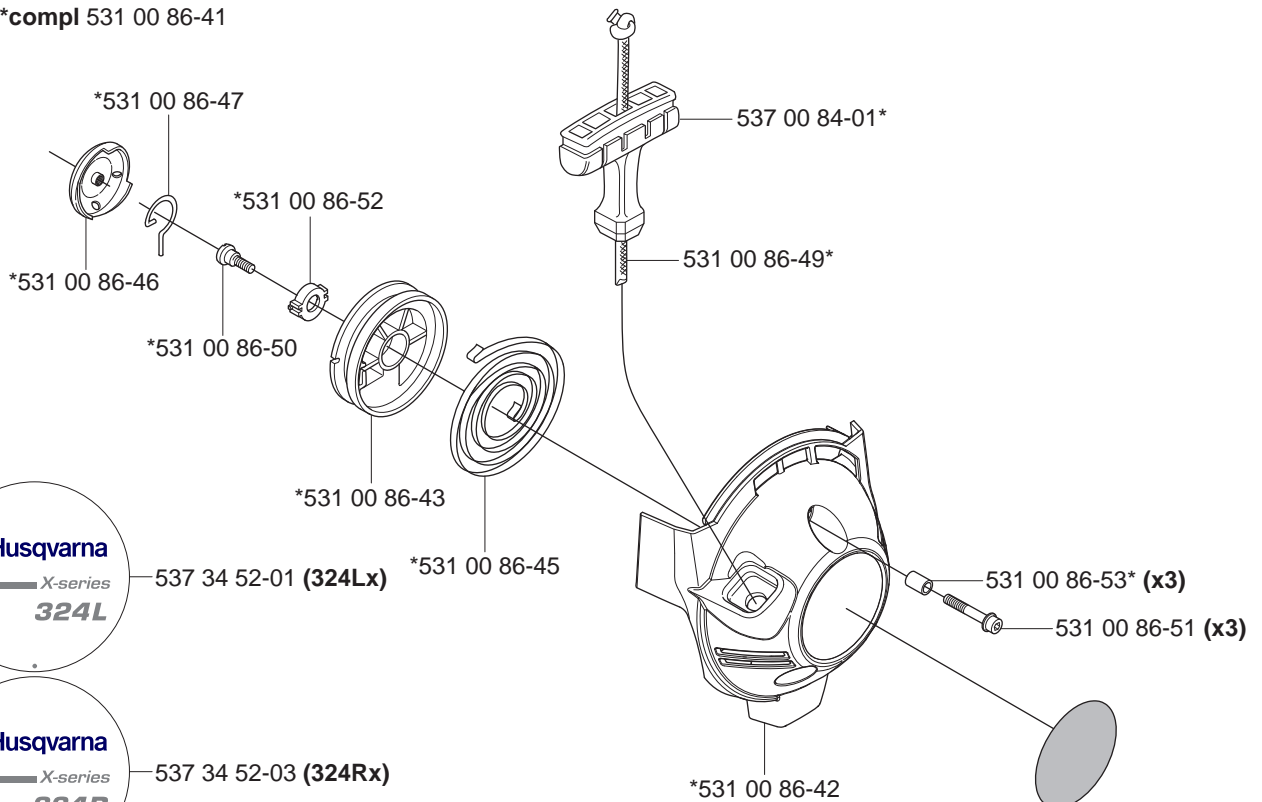

537 34 52-01 (324Lx)



537 34 52-03 (324Rx)



537 34 52-04 (324LDx)

537 34 52-01 (324Lx)
537 34 52-03 (324Rx)
537 34 52-04 (324LDx)

J

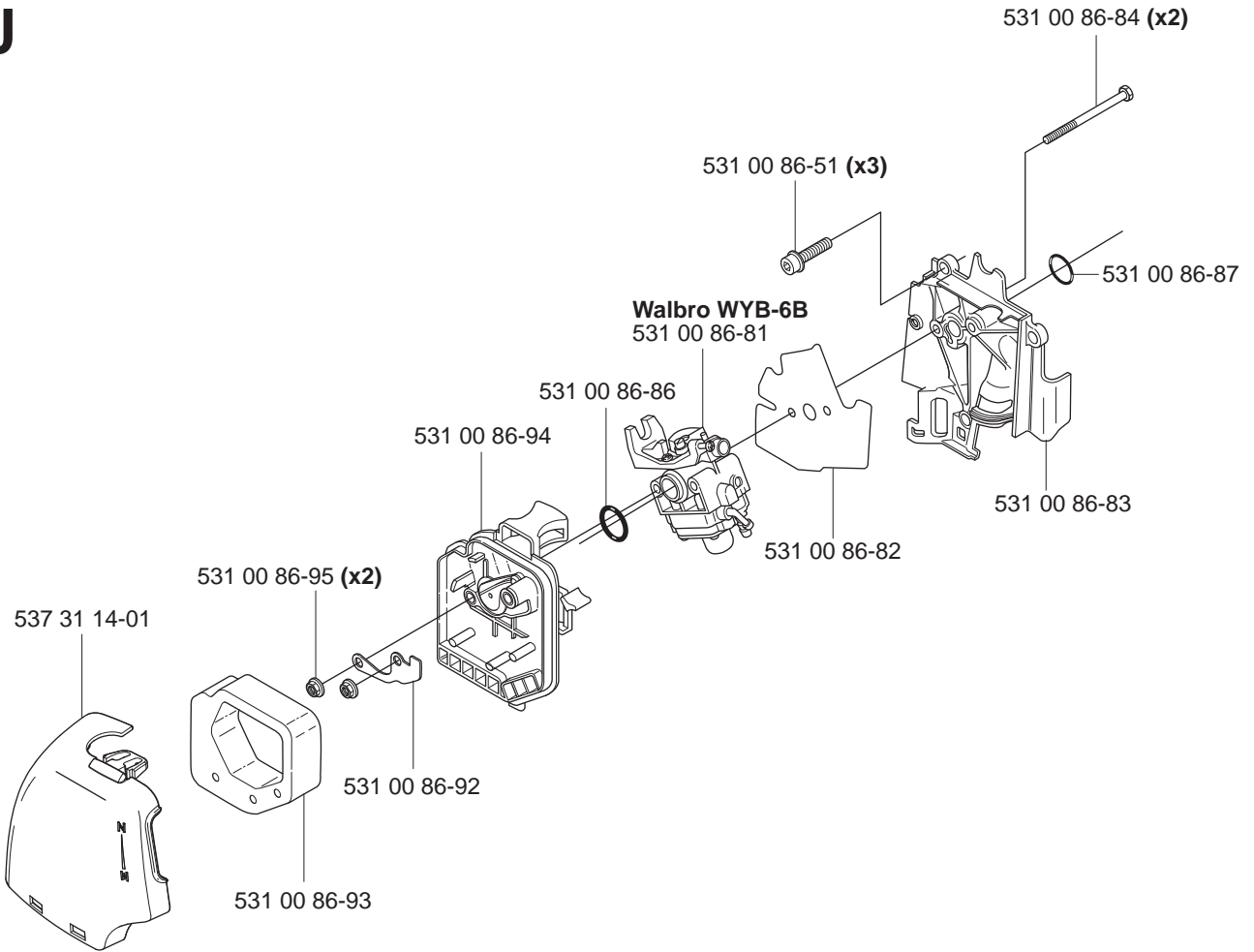

K

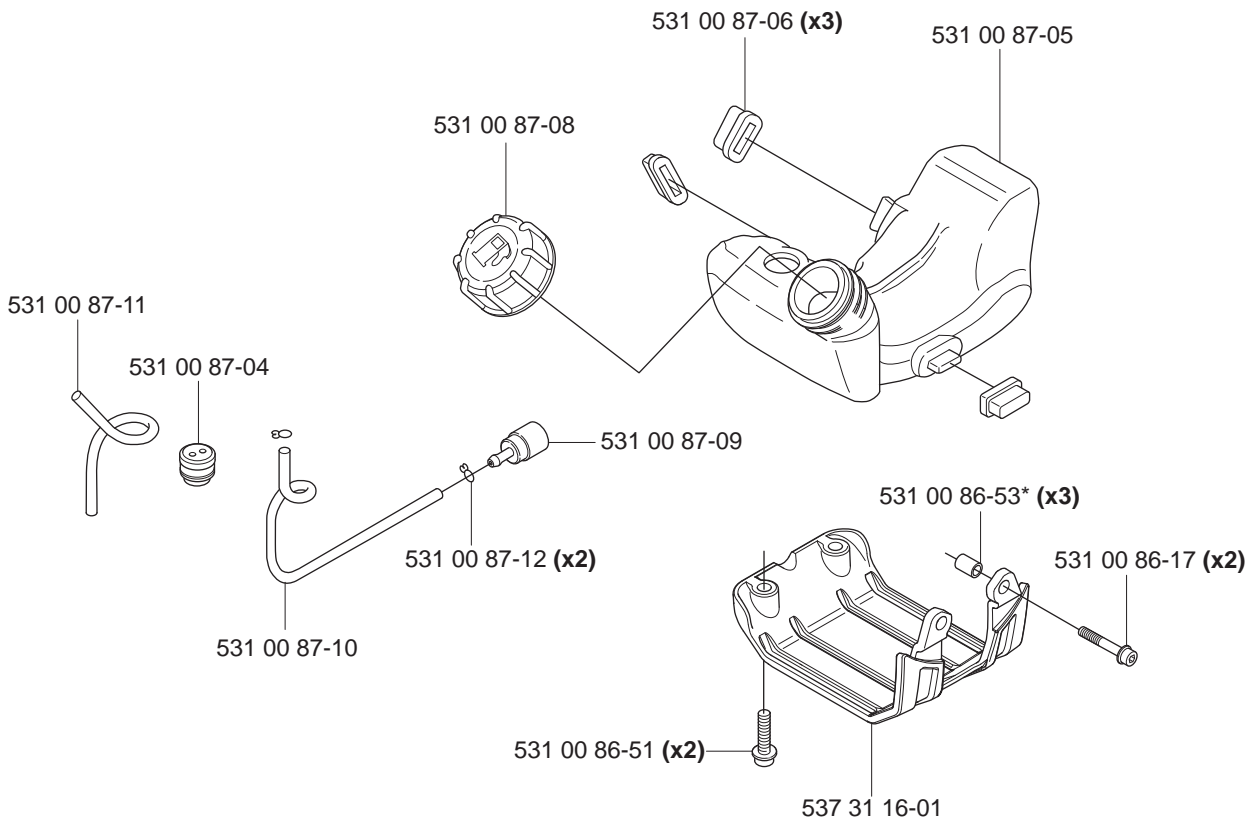

L

*compl 531 00 86-96

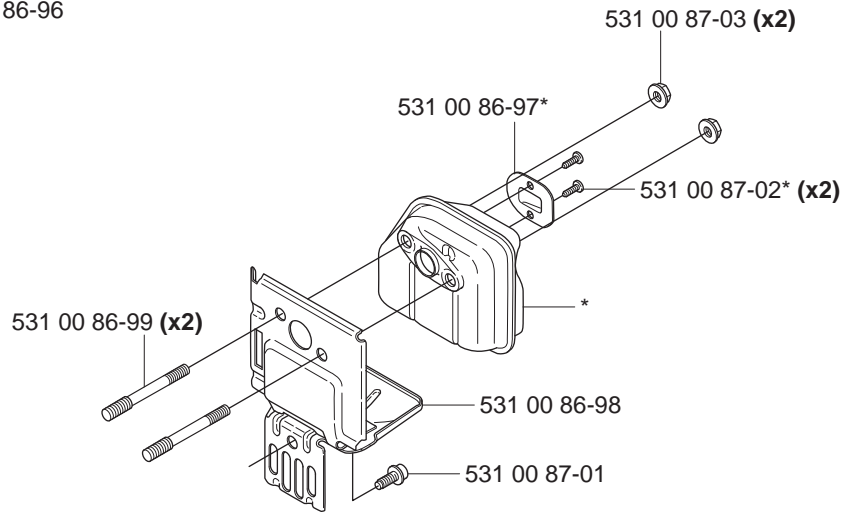
**M**

compl 531 00 87-17

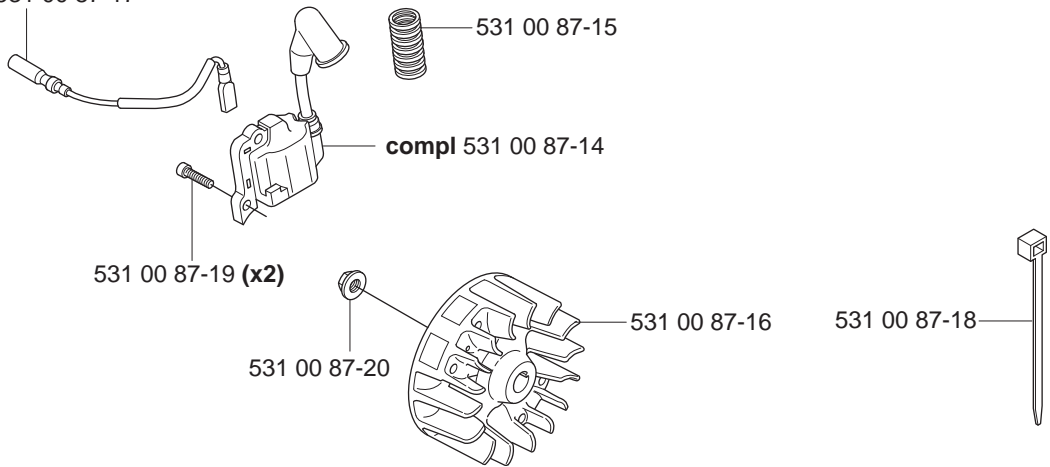
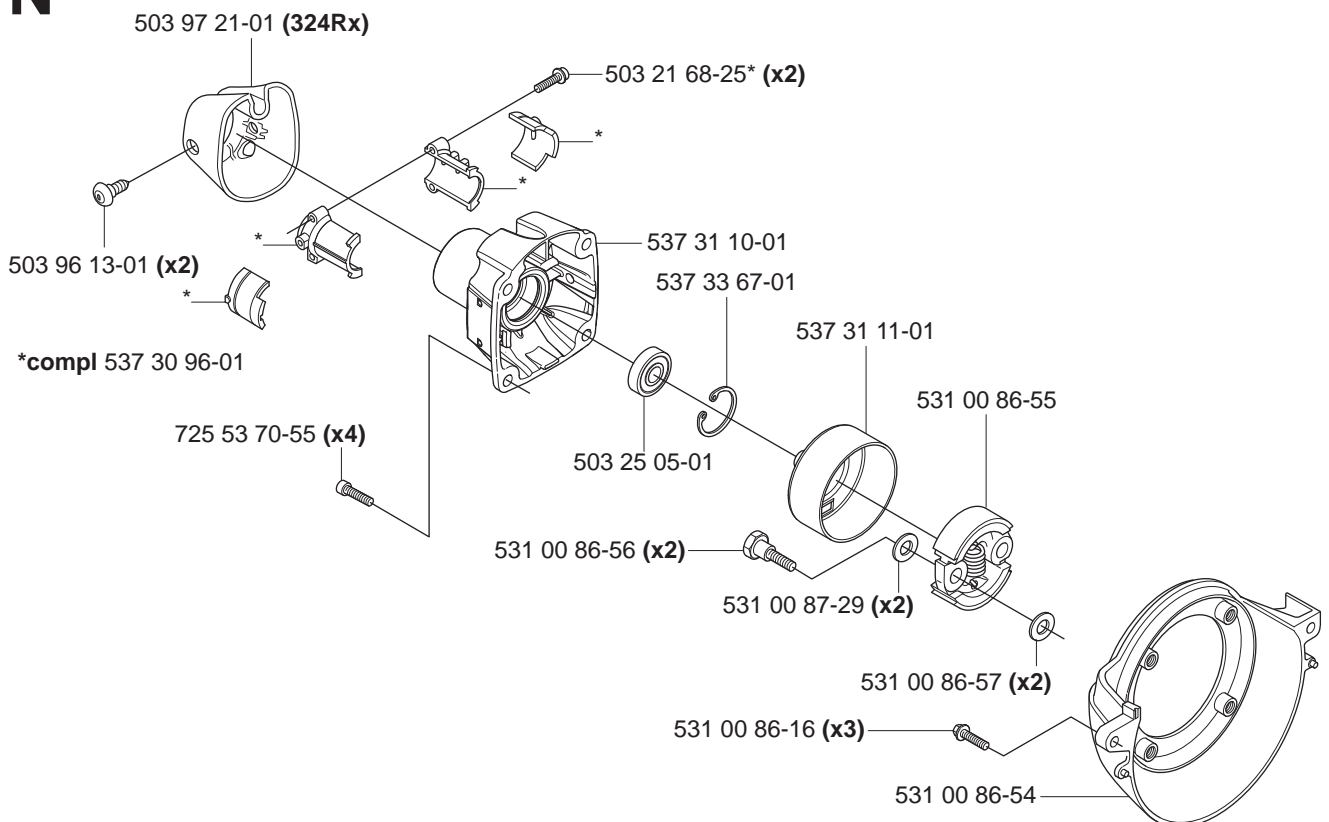
**N**

P

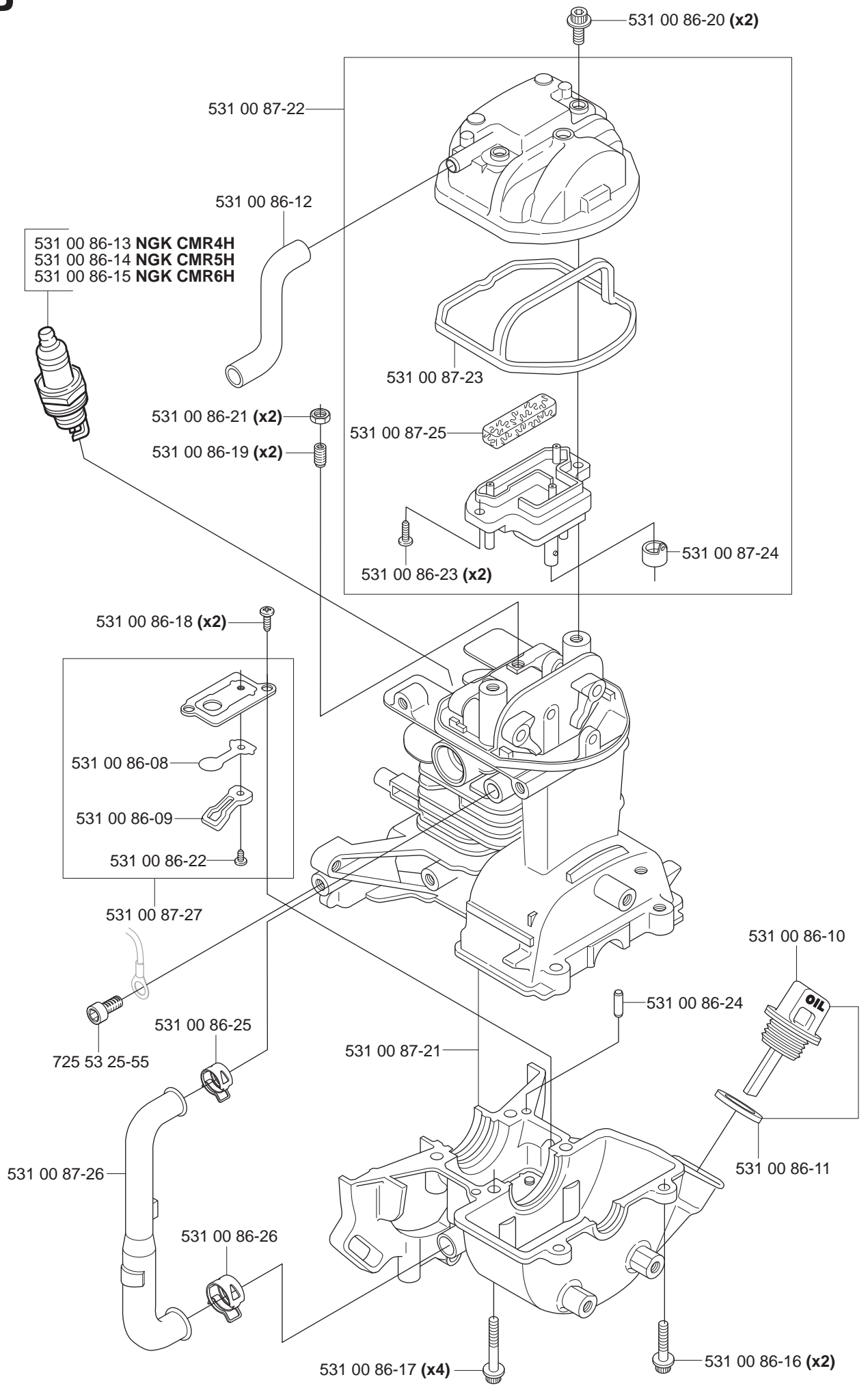

Q

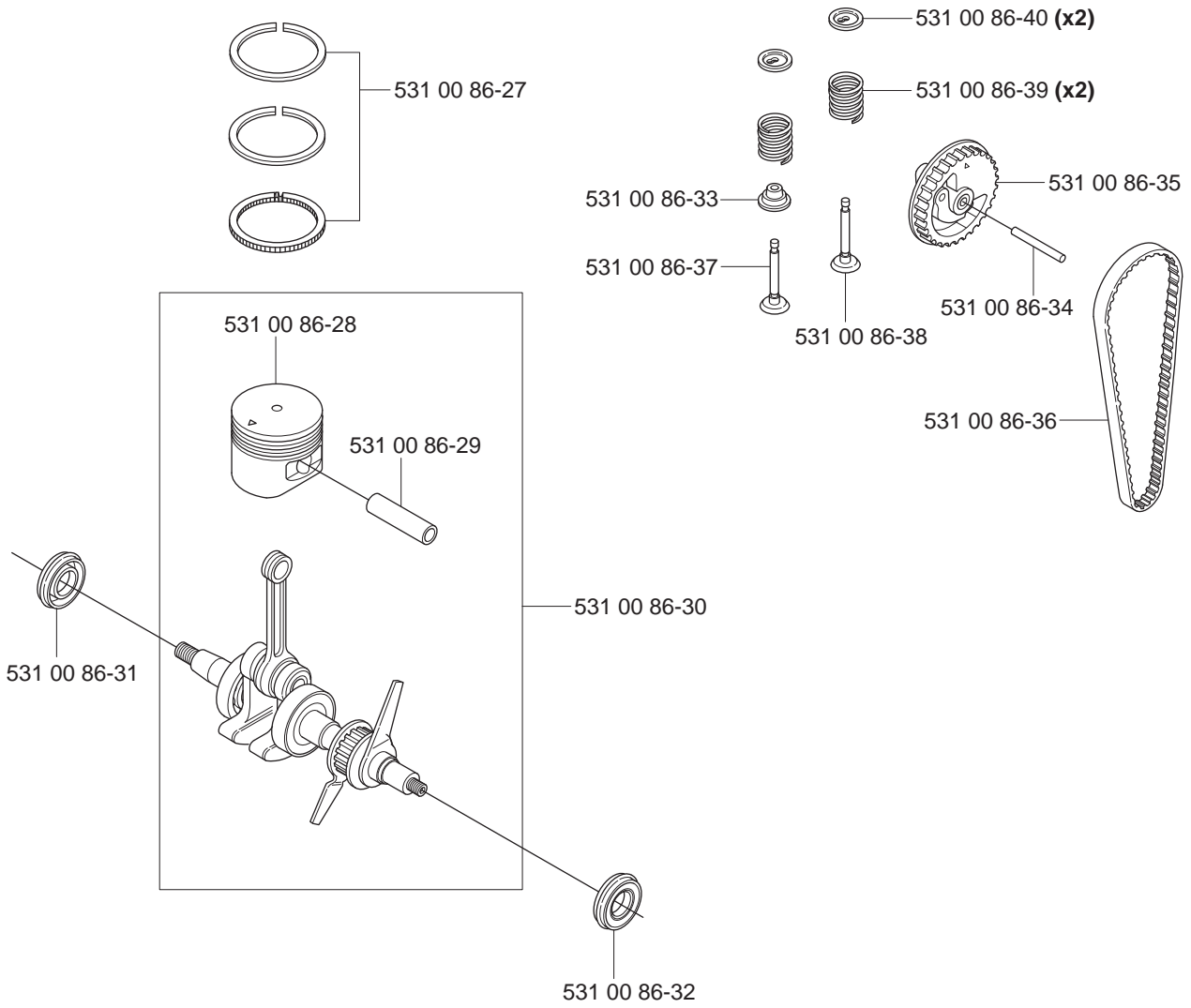

R Accessories Zubehöre Accessoires Accesorios Tillbehör

*compl 537 29 95-01
324Rx

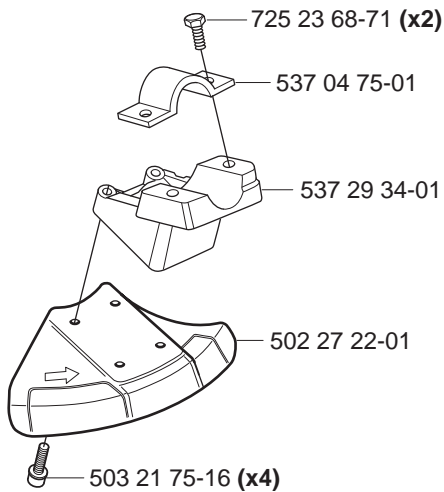

*compl 503 97 71-01
324Lx
324LDx

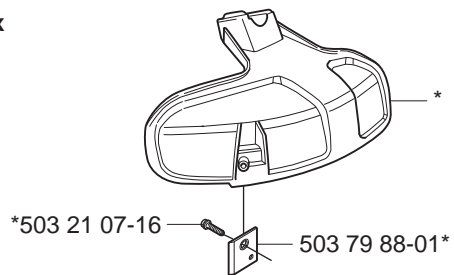

*compl 503 93 42-02
324Rx

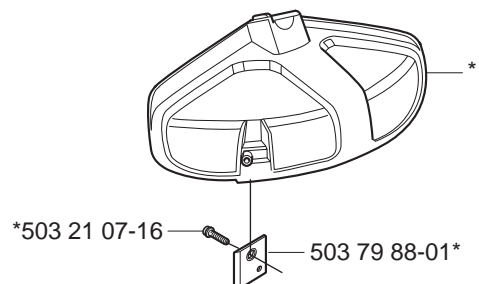

R Accessories
Zubehöre
Accessoires
Acessorios
Tillbehör

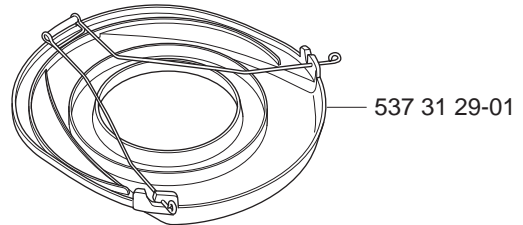
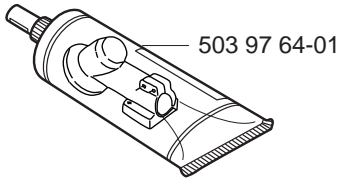
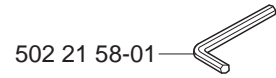
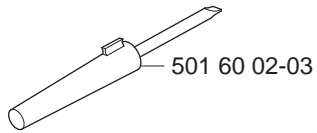
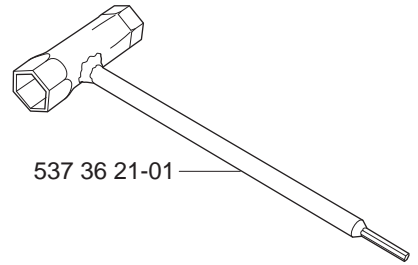
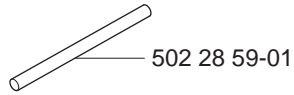

*compl 501 78 33-01

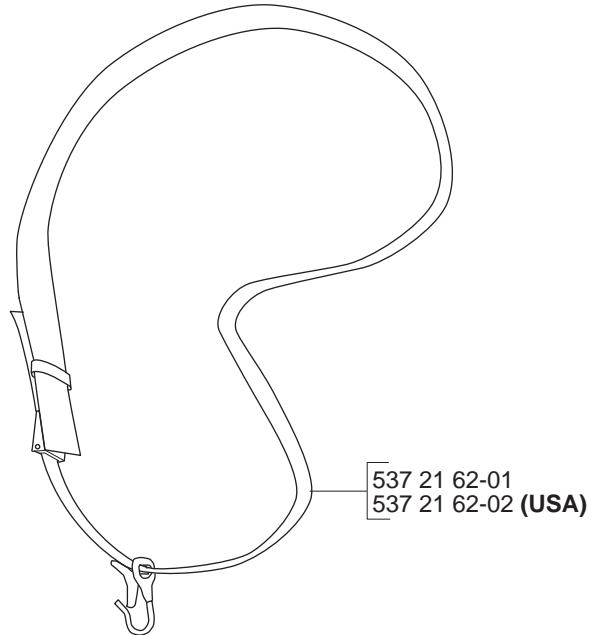
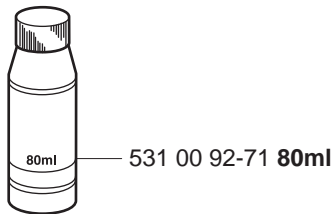
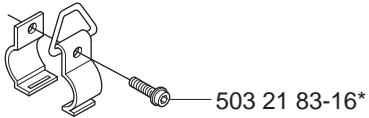

R

Duo Balance

*compl 537 27 57-02

*compl 537 27 57-04 US

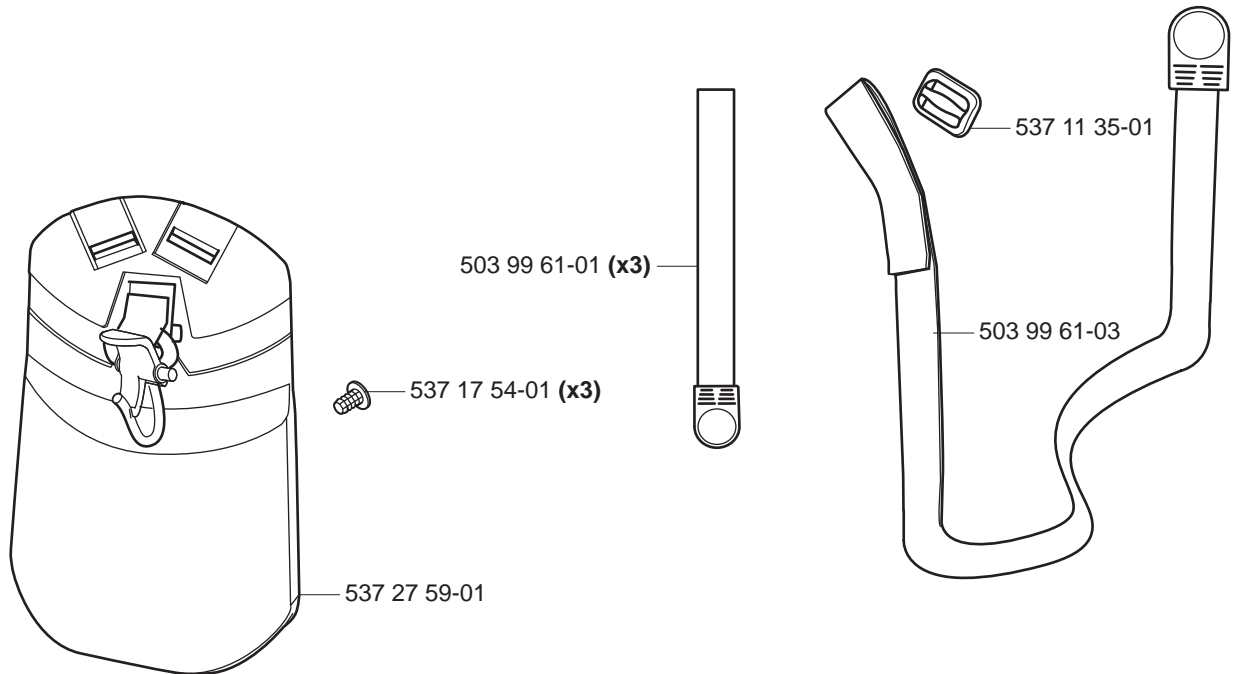
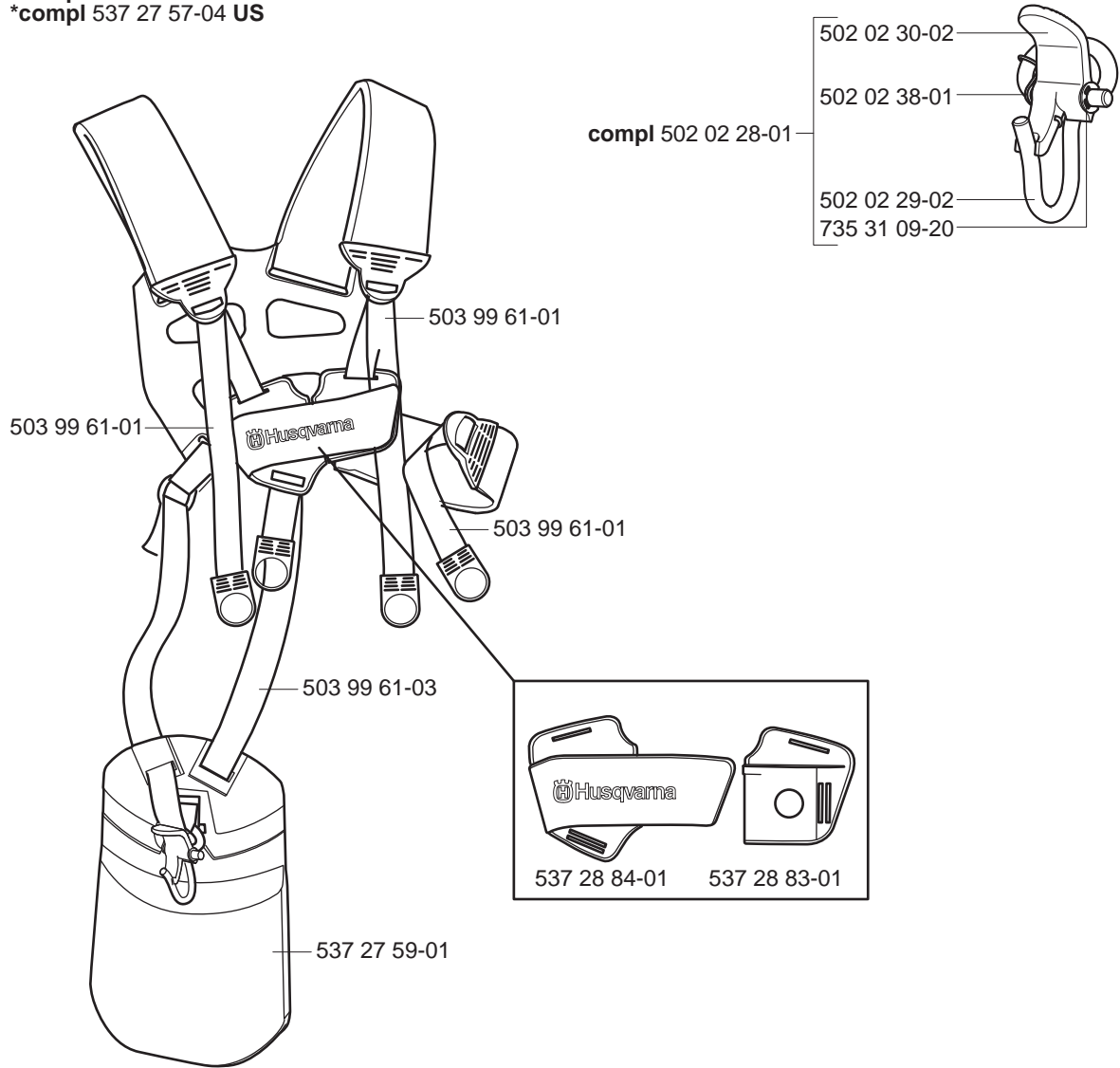

S

*compl 531 00 86-81 Walbro WYB-6B

Walbro WYB-6B

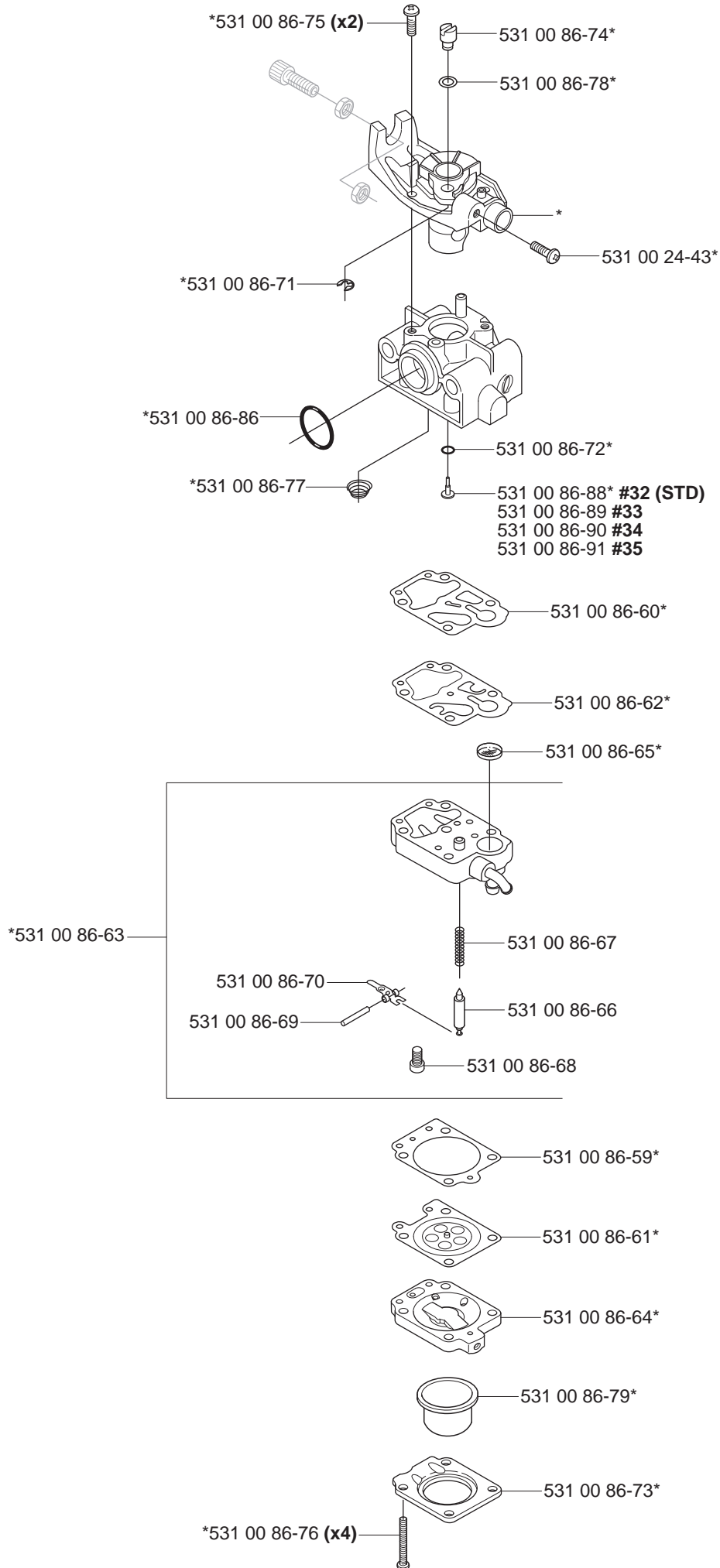

324Rx/324Lx/324LDx

Part Number	Description	Square		Part Number	Description	Square	
501 60 02-03	SCREWDRIVER	R		531 00 86-12	HOSE	P	
501 78 33-01	HANGING BRACKET	R		531 00 86-13	SPARK PLUG	P	
502 02 28-01	HARNES HOOK, COMPLETE	R		531 00 86-14	SPARK PLUG	P	
502 02 29-02	HOOK	R		531 00 86-15	SPARK PLUG	P	
502 02 30-02	CATCH	R		531 00 86-16	SCREW	NP	
502 02 38-01	SPRING	R		531 00 86-17	SCREW	KP	
502 19 71-01	NUT (LOOP HANDLE)	BCD		531 00 86-18	SCREW	P	
502 20 38-01	HANDLE	CD		531 00 86-19	SCREW	P	
502 21 12-01	GROMMET	D		531 00 86-20	SCREW	P	
502 21 58-01	L-KEY WRENCH	R		531 00 86-21	NUT	P	
502 27 22-01	BLADE GUARD	R		531 00 86-22	SCREW	P	
502 28 59-01	LOCKING PIN	R		531 00 86-23	SCREW	P	
502 28 61-01	CLAMP	G		531 00 86-24	PIN	P	
503 20 02-10	SCREW	C		531 00 86-25	CLIP	P	
503 20 02-45	SCREW	D		531 00 86-26	CLIP	P	
503 20 07-12	SCREW	A		531 00 86-27	PISTON RING	Q	
503 20 07-16	SCREW	D		531 00 86-28	PISTON	Q	
503 20 07-25	SCREW	AC		531 00 86-29	PISTON BOLT	Q	
503 20 07-35	SCREW	F		531 00 86-30	CRANKSHAFT	Q	
503 20 14-12	SCREW	A		531 00 86-31	SEALING RING	Q	
503 20 15-01	PLUG	A		531 00 86-32	SEALING RING	Q	
503 21 07-16	SCREW	R		531 00 86-33	SEALING	Q	
503 21 66-16	SCREW	F		531 00 86-34	SHAFT	Q	
503 21 66-20	SCREW	E		531 00 86-35	WHEEL	Q	
503 21 68-25	SCREW	N		531 00 86-36	BELT	Q	
503 21 75-16	SCREW	R		531 00 86-37	VALVE	Q	
503 21 75-25	SCREW	D		531 00 86-38	VALVE	Q	
503 21 83-16	SCREW 5X14	R		531 00 86-39	SPRING	Q	
503 22 10-13	NUT	F		531 00 86-40	RETAINER	Q	
503 25 05-01	BEARING	N		531 00 86-41	STARTER DEVICE	H	
503 25 24-01	BEARING	A		531 00 86-42	STARTER HOUSING	H	
503 70 80-04	ADAPTER	C		531 00 86-43	STARTER PULLEY	H	
503 71 54-01	BRACKET	C		531 00 86-45	RETURN SPRING	H	
503 71 82-01	START/STOP SWITCH	EF		531 00 86-46	CARRIER	H	
503 72 29-01	BRACKET	D		531 00 86-47	PAWL	H	
503 72 43-09	HANDLE	D		531 00 86-49	STARTER ROPE	H	
503 75 00-01	HOLDER	D		531 00 86-50	SCREW	GHJK	
503 78 52-01	BUSHING	C		531 00 86-52	HOLDER	H	
503 79 56-01	DECAL WARNING "NO BLADES"	BC		531 00 86-53	SLEEVE	HK	
503 79 88-01	LINE CUTTER	R		531 00 86-54	HOUSING	N	
503 85 29-06	HANDLE, COMPLETE 324LX/LCX	E		531 00 86-55	CLUTCH	N	
503 85 63-01	GEARHEAD NUT - BRUSHCUTTER	A		531 00 86-56	SCREW	N	
503 86 45-01	DRIVE SHAFT	BD		531 00 86-57	WASHER	N	
503 87 19-03	HANDLE, LOOP	BC		531 00 86-59	GASKET	S	
503 87 79-01	THROTTLE TRIGGER	E		531 00 86-60	GASKET	S	
503 87 80-01	THROTTLE LOCK	E		531 00 86-61	DIAPHRAGM	S	
503 87 90-01	KNOB	BC		531 00 86-62	PUMP DIAPHRAGM	S	
503 88 23-01	HOLDER	D		531 00 86-63	HOUSING	S	
503 88 88-01	DRIVE TUBE ASSEMBLY	BD		531 00 86-64	HOUSING	S	
503 91 81-01	LEVER	E		531 00 86-65	SCREEN	S	
503 93 42-02	GRASS SHIELD	R		531 00 86-66	VALVE	S	
503 93 55-01	BRACKET TRIMMER GUARD	A		531 00 86-67	SPRING	S	
503 94 03-01	SPACER PLASTIC	BC		531 00 86-68	SCREW	S	
503 94 10-01	HARNES HOLDER	D		531 00 86-69	SHAFT	S	
503 96 13-01	SCREW MT5X11	EN		531 00 86-70	LEVER	S	
503 96 14-01	VIBRATION DAMPER	E		531 00 86-71	RETAINING RING	S	
503 97 21-01	COVER	N		531 00 86-72	O-RING	S	
503 97 64-01	BEVEL GEAR GREASE	R		531 00 86-73	COVER	S	
503 97 71-01	TRIMMER GUARD ASSEMBLY	R		531 00 86-74	SWIVEL	S	
503 98 54-01	HOLDER	C		531 00 86-75	SCREW	S	
503 99 55-02	HANDLE	E		531 00 86-76	SCREW	S	
503 99 56-02	HANDLE	E		531 00 86-77	SPRING	S	
503 99 61-01	BAND	R		531 00 86-78	WASHER	S	
503 99 61-03	BAND	R		531 00 86-79	PUMP	S	
531 00 24-43	SCREW	S		531 00 86-81	CARBURETOR	JS	
531 00 86-08	BLADE	P		531 00 86-82	GASKET	J	
531 00 86-09	MOVEMENT LIMITER	P		531 00 86-83	SPACER	J	
531 00 86-10	GUAGE	P		531 00 86-84	SCREW	J	
531 00 86-11	GASKET	P		531 00 86-86	O-RING	JS	

324Rx/324Lx/324LDx

Part Number	Description	Square	Part Number	Description	Square
531 00 86-88	JET	S	531 00 86-87	O-RING	J
531 00 86-89	JET	S	537 27 59-01	PROTECTOR	R
531 00 86-90	JET	S	537 28 56-01	SUPPORT FLANGE	A
531 00 86-91	JET	S	537 28 83-01	FRONT PIECE	R
531 00 86-92	PLATE	J	537 28 84-01	FRONT PIECE	R
531 00 86-93	AIR FILTER	J	537 29 26-01	WASHER	A
531 00 86-94	HOLDER	J	537 29 34-01	ADAPTER	R
531 00 86-95	NUT	J	537 29 95-01	CUTTING SHIELD 324RX, COMPLETE	R
531 00 86-96	MUFFLER	L	537 30 96-01	COMPRESION SLEEVE/ISOLATOR SET	N
531 00 86-97	SCREEN	L	537 31 10-01	CLUTCH COVER	N
531 00 86-98	AIR CONDUCTOR	L	537 31 11-01	CLUTCH DRUM	BCDN
531 00 86-99	STUD	L	537 31 14-01	COVER, AIR CLEANER	J
531 00 87-01	SCREW	L	537 31 16-01	PROTECTOR	K
531 00 87-02	SCREW	L	537 31 29-01	BLADE GUARD TRANSPORT	R
531 00 87-03	NUT	L	537 33 51-01	CABLE ASSY	E
531 00 87-04	GROMMET	K	537 33 57-01	CABLE ASSY	F
531 00 87-05	TANK UNIT	K	537 33 67-01	RETAINING CLIP, CLUTCH BAERING	N
531 00 87-06	RUBBER	K	537 34 52-01	DECAL	H
531 00 87-08	TANK CAP	K	537 34 52-03	DECAL	H
531 00 87-09	FILTER	K	537 34 52-04	DECAL	H
531 00 87-10	HOSE	K	537 34 53-01	DECAL	G
531 00 87-11	HOSE	K	537 34 53-03	DECAL	G
531 00 87-12	CLIP	K	537 34 53-04	DECAL	G
531 00 87-14	IGNITION MODULE	M	537 36 21-01	COMBI TOOL	R
531 00 87-15	HOSE	M	725 23 68-71	BOLT FLANGE - M6X20	R
531 00 87-16	FLYWHEEL	M	725 23 70-51	SCREW M6S 6X20	A
531 00 87-17	SHORTING LEAD	M	725 23 79-51	SCREW	C
531 00 87-18	BAND	M	725 23 80-51	SCREW M6X50	BC
531 00 87-19	SCREW	M	725 23 86-51	SCREW.	D
531 00 87-20	NUT	M	725 53 25-55	SCREW MC6S 5X10	P
531 00 87-21	CRANKCASE / CYLINDER	P	725 53 70-55	SCREW MC6S 6X20	N
531 00 87-22	COVER	P	731 23 14-01	NUT	D
531 00 87-23	GASKET	P	735 31 09-20	E-RING 5	R
531 00 87-24	SEALING	P	735 31 11-00	RETAINING RING	A
531 00 87-25	FILTER	P	735 31 25-10	RETAINING RING	A
531 00 87-26	HOSE	P	735 31 28-10	RETAINING RING SGH 28	A
531 00 87-27	VALVE	P	735 58 08-10	WASHER	C
531 00 87-28	CYLINDER	G	738 21 98-00	BALL BEARING 8X22X7/608Z	A
531 00 92-71	4 STROKE ENGINE OIL	R	738 21 99-00	BALL BEARING 24X9X1/609ZR	A
537 00 84-01	STARTER HANDLE	H	738 21 99-02	BEARING	A
537 01 13-01	SPRING	E	740 42 06-00	O-RING 8X1.6	E
537 01 16-01	TUBE	C			
537 01 19-01	SHAFT LOWER	C			
537 02 76-01	DECAL WARNING	BCD			
537 04 75-01	CLAMP	R			
537 08 27-01	TUBE	C			
537 08 30-01	SHAFT UPPER	C			
537 11 35-01	CLIP	R			
537 16 02-02	HANDLE	F			
537 16 03-02	HANDLE	F			
537 16 06-01	THROTTLE LOCK	F			
537 16 07-01	THROTTLE LOCK	F			
537 16 08-01	THROTTLE TRIGGER	F			
537 16 09-01	STEERING WHEEL	F			
537 16 10-01	HUB	F			
537 16 12-01	SCREW	F			
537 17 28-01	HANDLE	D			
537 17 29-01	BRACKET	D			
537 17 42-01	SPRING	F			
537 17 43-01	SPRING	F			
537 17 44-01	PLATE	F			
537 17 54-01	RIVET	R			
537 18 35-01	THROTTLE HANDLE	F			
537 18 36-01	SPRING	F			
537 19 92-02	GEAR HEAD	A			
537 21 62-01	STRAP	R			
537 21 62-02	SHOULDER STRAP	R			
537 23 49-01	DRIVE DISC	A			
537 27 57-02	HARNESS	R			
537 27 57-04	DUO BALANCE HARNESS, COMPLETE	R			

IPL, 324 Rx, 324 Lx, 324 LDx, 2004-05, 106 40 10-61