

338XPT

Spare parts

Ersatzteile

Pièces détachées

Reserve onderdelen

Repuestos

Reservdelar

PART NUMBER	SQUARE	NOTE	PART NUMBER	SQUARE	NOTE	PART NUMBER	SQUARE	NOTE	PART NUMBER	SQUARE	NOTE
501 45 27-02	L		503 81 35-01	M		537 10 04-01	J				
501 45 41-01	L		503 81 69-01	M		537 10 65-01	L				
501 45 43-01	L		503 81 71-01	A		537 11 32-03	J				
501 48 54-02	G		503 81 73-01	L		537 11 41-01	P				
501 62 33-01	L		503 81 81-01	G		537 12 68-06	J				
501 62 98-01	M		503 81 85-01	H		537 13 20-01	J				
501 68 68-01	L		503 82 09-02	C		537 13 27-01	J				
501 69 17-01	P		503 82 11-01	J		537 15 77-01	J				
501 76 31-01	H		503 82 17-01	F		537 16 21-04	G				
501 81 92-01	L		503 82 22-71	B		537 16 73-01	J				
501 82 25-01	M		503 82 25-03	H		537 18 00-01	J				
501 83 44-09	P		503 82 27-02	M		537 20 19-01	H				
501 87 53-01	A		503 82 28-01	M		537 21 52-02	M				
502 20 40-01	C		503 82 33-02	M		537 21 52-04	M				
502 20 65-03	C		503 84 26-01	M		537 23 39-01	G				
503 14 51-01	B		503 84 27-01	L		537 24 19-01	D				
503 18 49-01	L		503 85 13-01	M		537 24 95-04	M				
503 20 02-16	F		503 85 38-04	M		537 27 31-01	N				
503 20 02-16	L,M		503 85 46-01	A		537 27 33-01	N				
503 20 02-25	L		503 85 51-01	A		537 27 34-01	N				
503 20 02-40	L		503 86 20-01	A		537 27 35-01	N				
503 20 25-16	G		503 86 38-01	L		537 27 36-01	N				
503 20 49-01	Q		503 90 09-01	G		537 27 37-01	N				
503 21 28-10	A,M		503 90 32-01	N		537 27 38-01	N				
503 21 56-01	M,Q		503 90 33-01	N		537 27 39-01	N				
503 21 58-25	E,H		503 90 34-01	N		537 27 40-01	N				
503 21 75-50	D		503 90 83-01	A		537 27 41-01	N				
503 21 77-16	H		503 90 87-03	H		537 27 42-01	N				
503 21 88-30	M		503 90 88-01	A		537 27 43-01	N				
503 22 00-01	A		503 90 98-02	G		537 27 44-01	N				
503 22 10-11	G		503 92 42-01	G		537 33 28-01	D				
503 23 00-16	L		503 92 96-01	M		537 37 62-01	Q				
503 23 51-08	J		503 93 03-03	F		537 37 67-01	K				
503 25 46-01	B		503 93 45-02	K		537 38 83-01	N				
503 26 30-17	M		503 93 52-03	A		537 39 05-01	M,Q				
503 28 34-04	D,N		503 93 53-01	A		537 40 98-01	Q				
503 28 90-03	J		503 93 66-01	M		537 41 35-01	N				
503 41 41-01	J,K		503 96 32-01	M		720 12 33-00	A				
503 44 32-01	M		503 96 71-01	D		720 12 40-20	M				
503 47 89-01	N		503 96 71-02	D		720 12 46-20	M				
503 47 90-01	N		503 96 72-01	D		724 12 87-59	F				
503 47 96-01	N		503 96 72-02	D		729 56 55-01	M				
503 47 97-01	N		503 96 75-01	M		735 31 08-20	A				
503 48 00-01	N		503 97 40-01	N		735 31 10-20	A				
503 48 01-01	N		503 97 43-01	N		737 44 10-00	J				
503 48 05-01	N		503 97 81-02	L							
503 48 11-01	N		503 97 82-01	L							
503 48 18-01	N		503 98 13-01	M							
503 52 12-04	B		503 98 62-01	L							
503 53 57-01	N		503 98 74-01	A							
503 55 22-01	J		503 98 94-02	L							
503 57 76-02	M		504 34 00-04	J							
503 57 89-01	M		505 30 51-25	H							
503 60 04-01	M		530 02 61-19	M							
503 66 59-01	N		531 00 45-52	N							
503 71 02-03	G		537 00 84-01	H							
503 71 40-03	B		537 01 25-01	N							
503 72 31-01	L		537 01 26-01	N							
503 73 58-01	M		537 01 97-01	N							
503 78 92-01	L		537 02 00-01	N							
503 79 05-02	G		537 02 01-01	N							
503 79 22-04	L		537 02 04-01	N							
503 79 25-01	H		537 02 15-02	D							
503 79 26-02	C		537 04 24-08	M							
503 80 52-01	A		537 04 24-09	M							
503 80 83-02	L		537 04 61-01	L							
503 80 97-02	A		537 04 89-01	N							
503 81 14-02	E		537 05 28-01	M							
503 81 32-01	M		537 05 68-01	L							
503 81 34-01	M		537 09 28-01	A							

Set of gaskets, Dichtungssatz,
Jeu de joints, Juego de juntas,
Packningssats

A

*compl 503 93 52-03

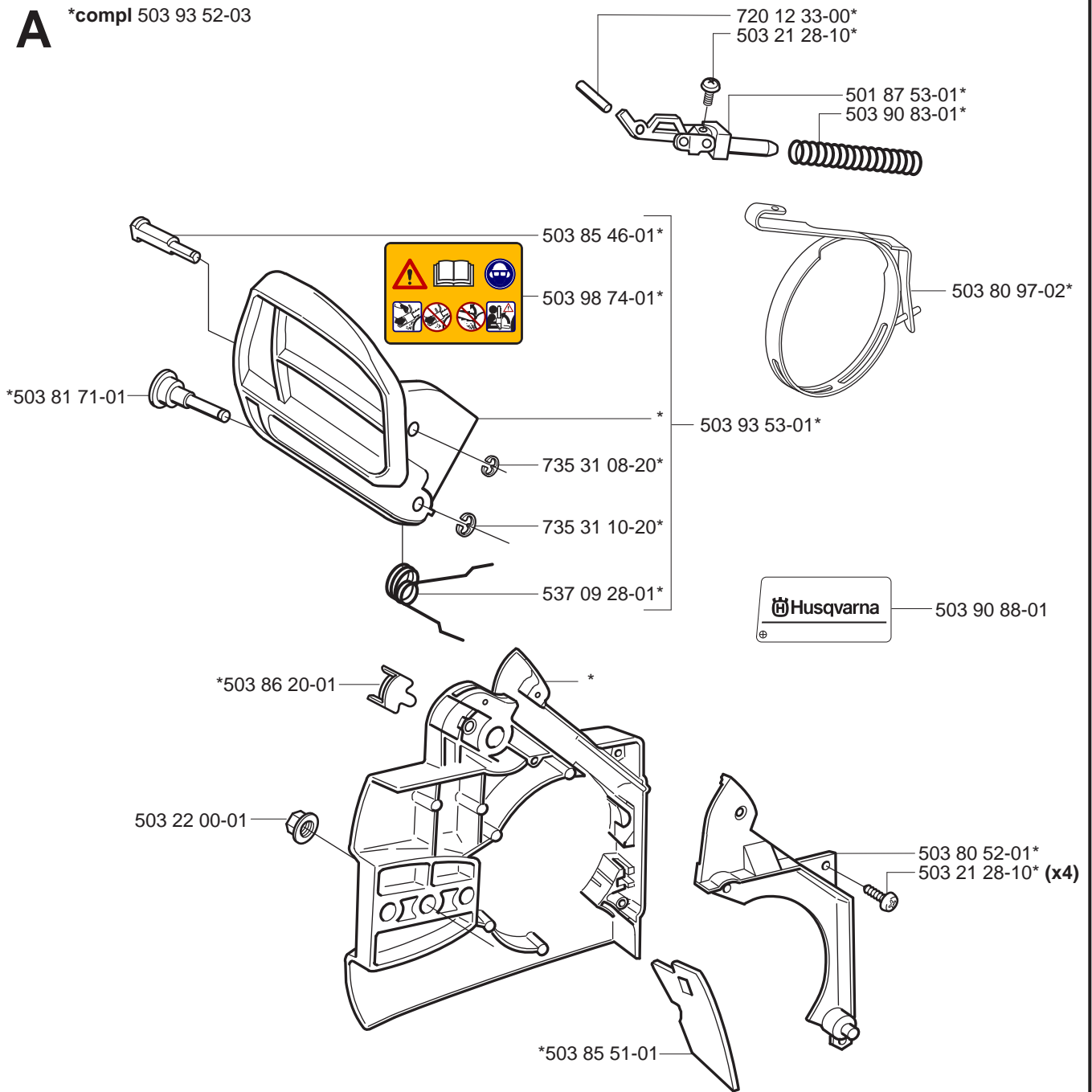

B

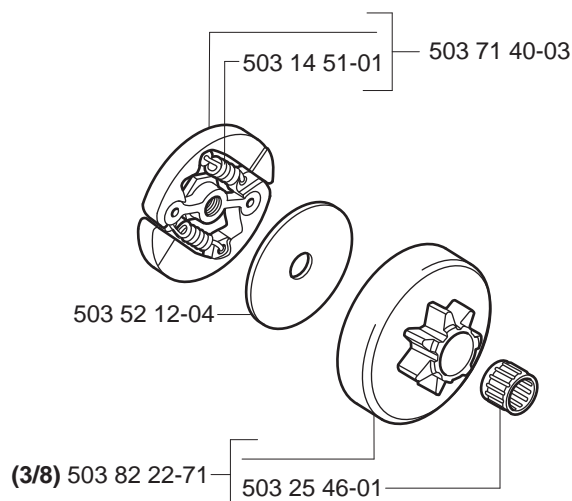

C *compl 503 79 26-02

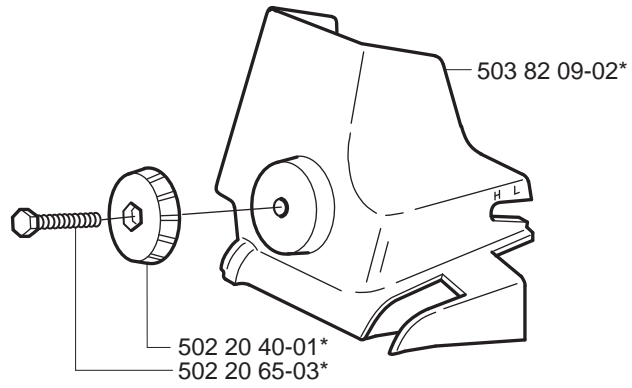

D *compl 537 02 15-02

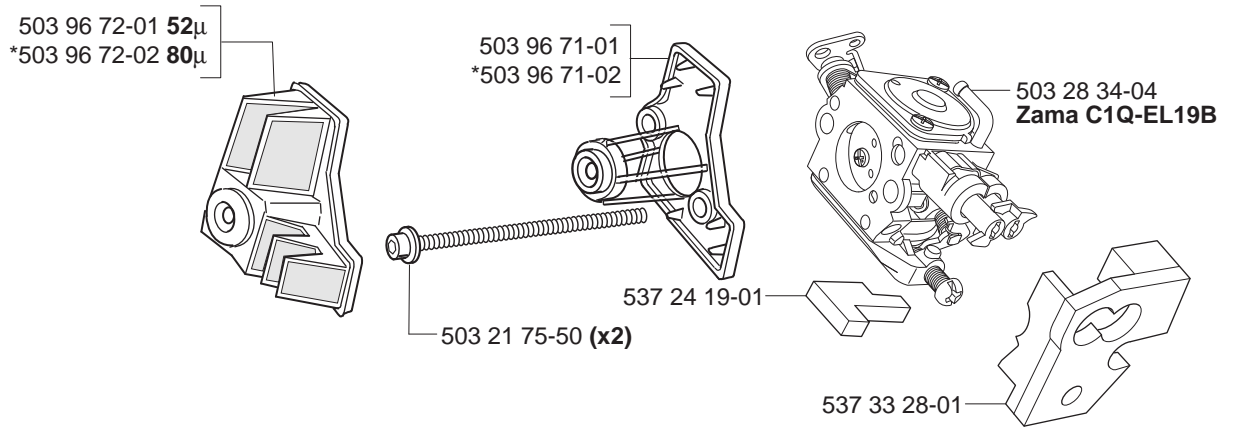

E

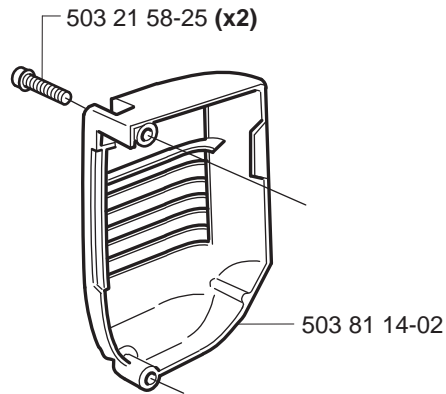

F *compl 503 93 03-03

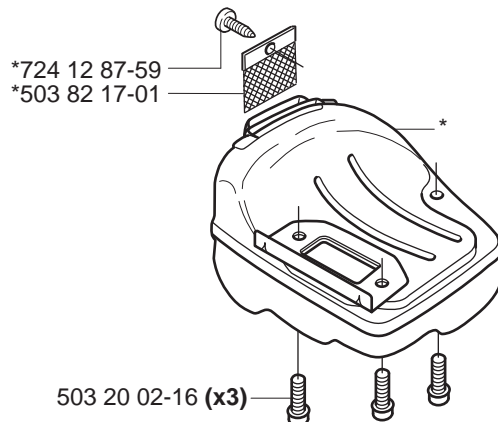

G

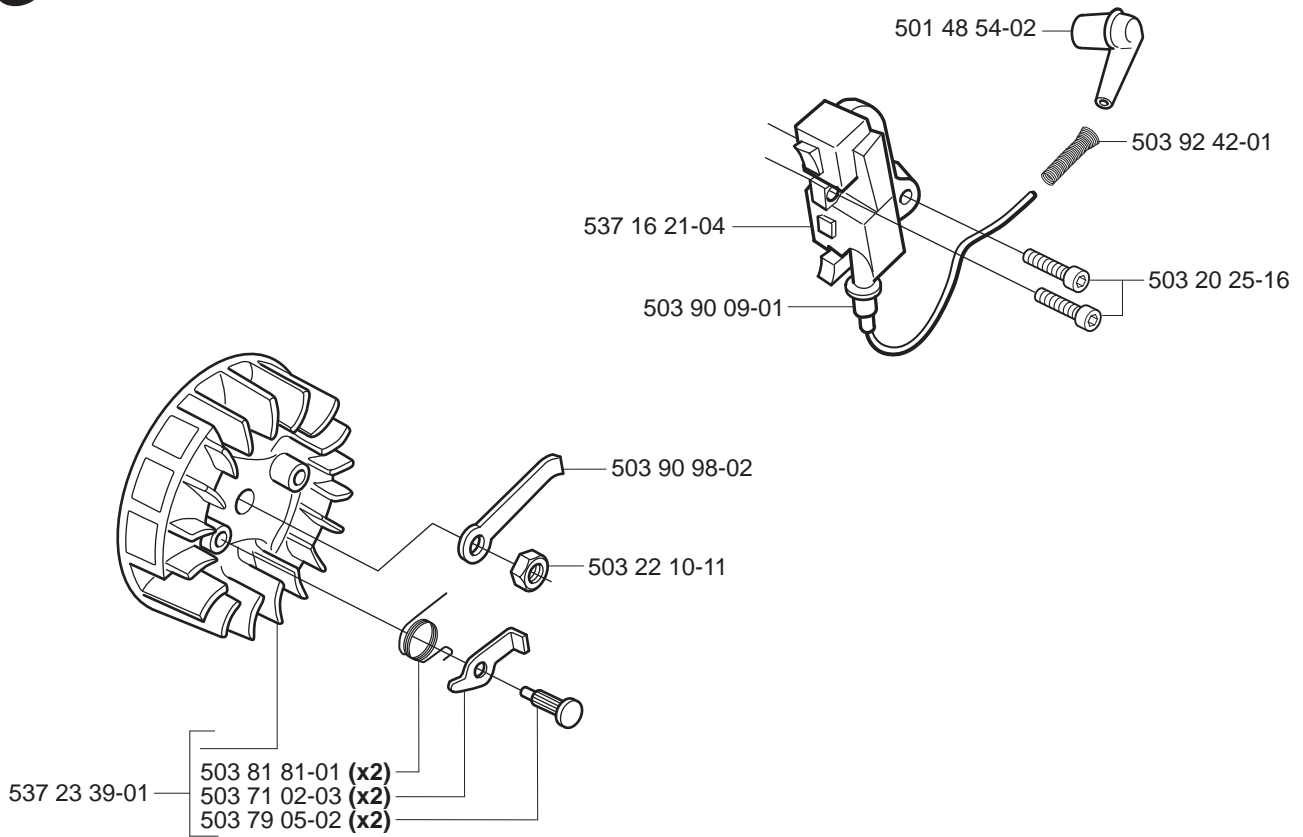

H

*compl 503 79 25-01

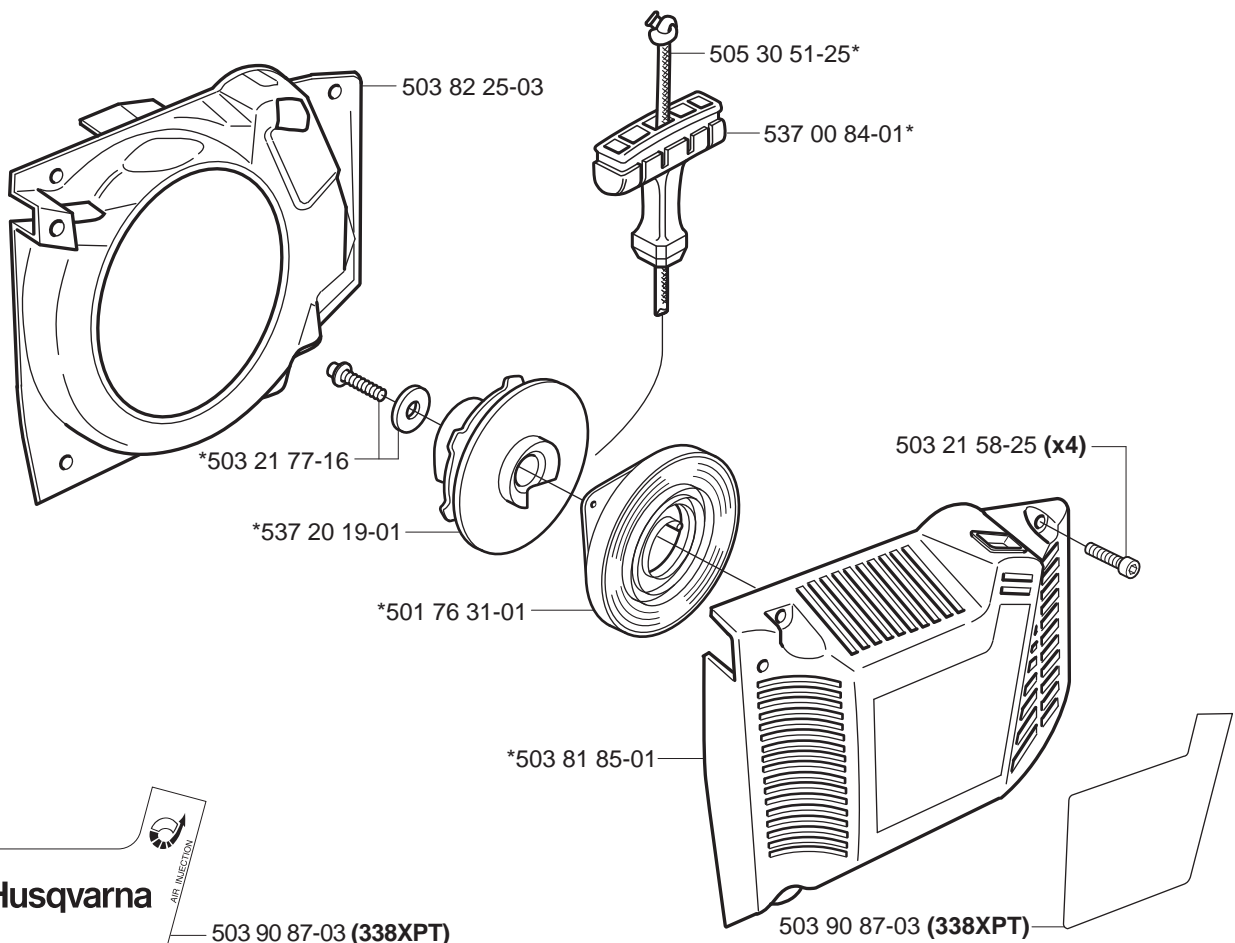

J

*compl 537 13 20-01

**compl 537 16 73-01

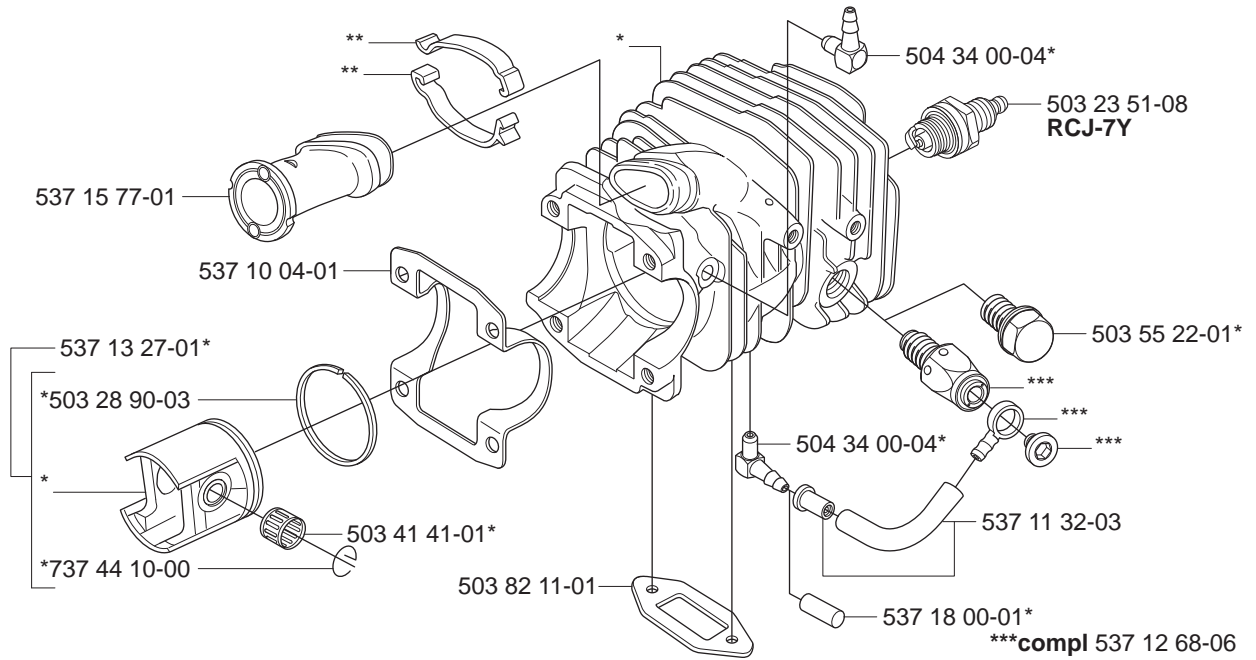
**K**

*compl 537 37 67-01

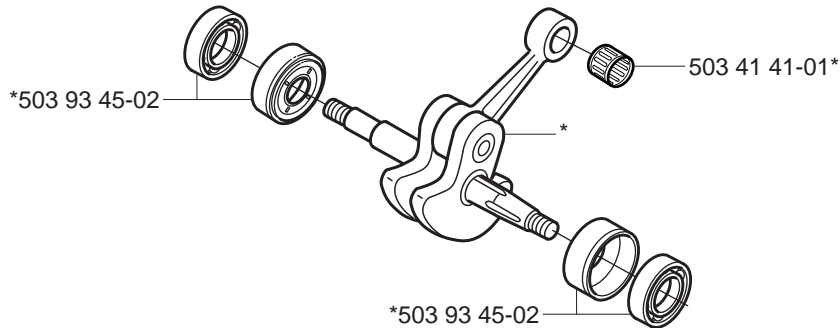
**L**

*compl 503 79 22-04

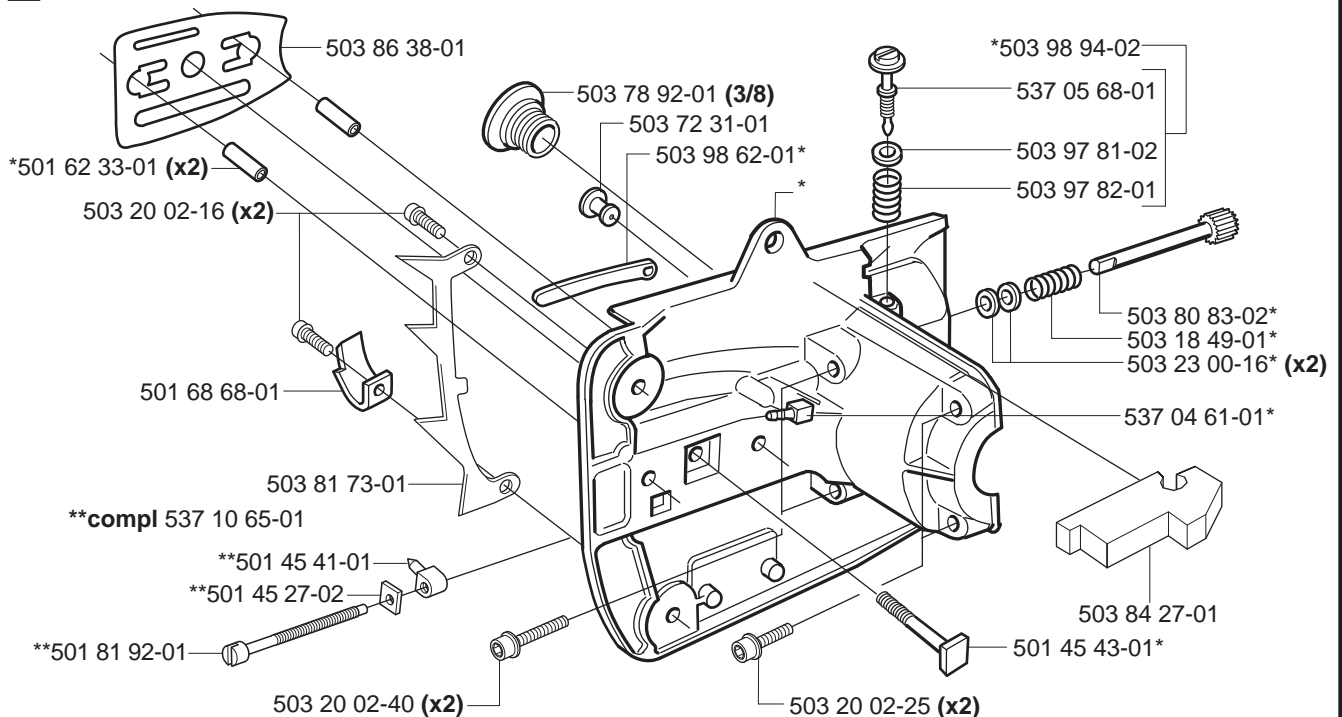

M

*compl 537 24 95-04

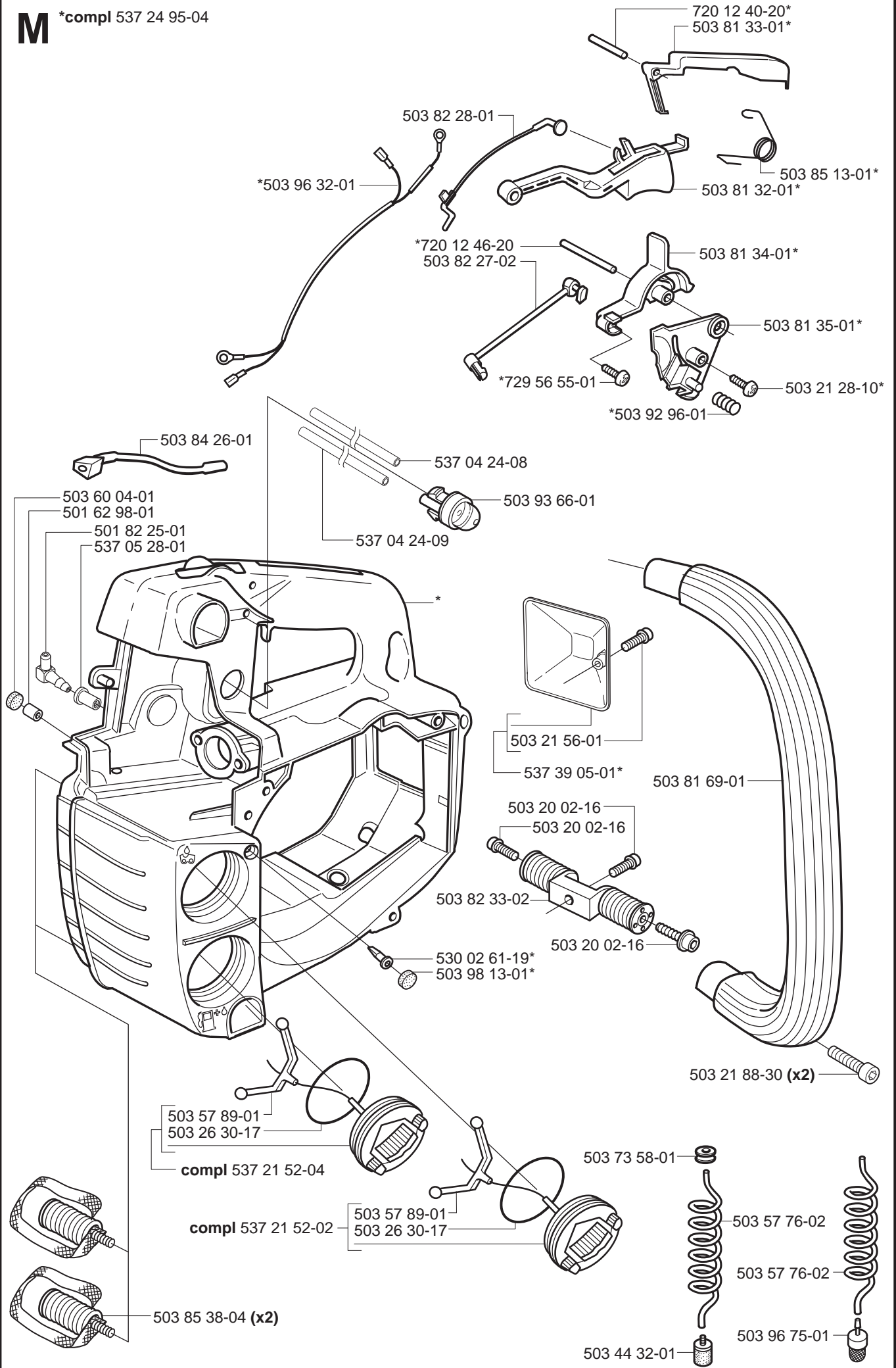

N

*compl 503 28 34-04

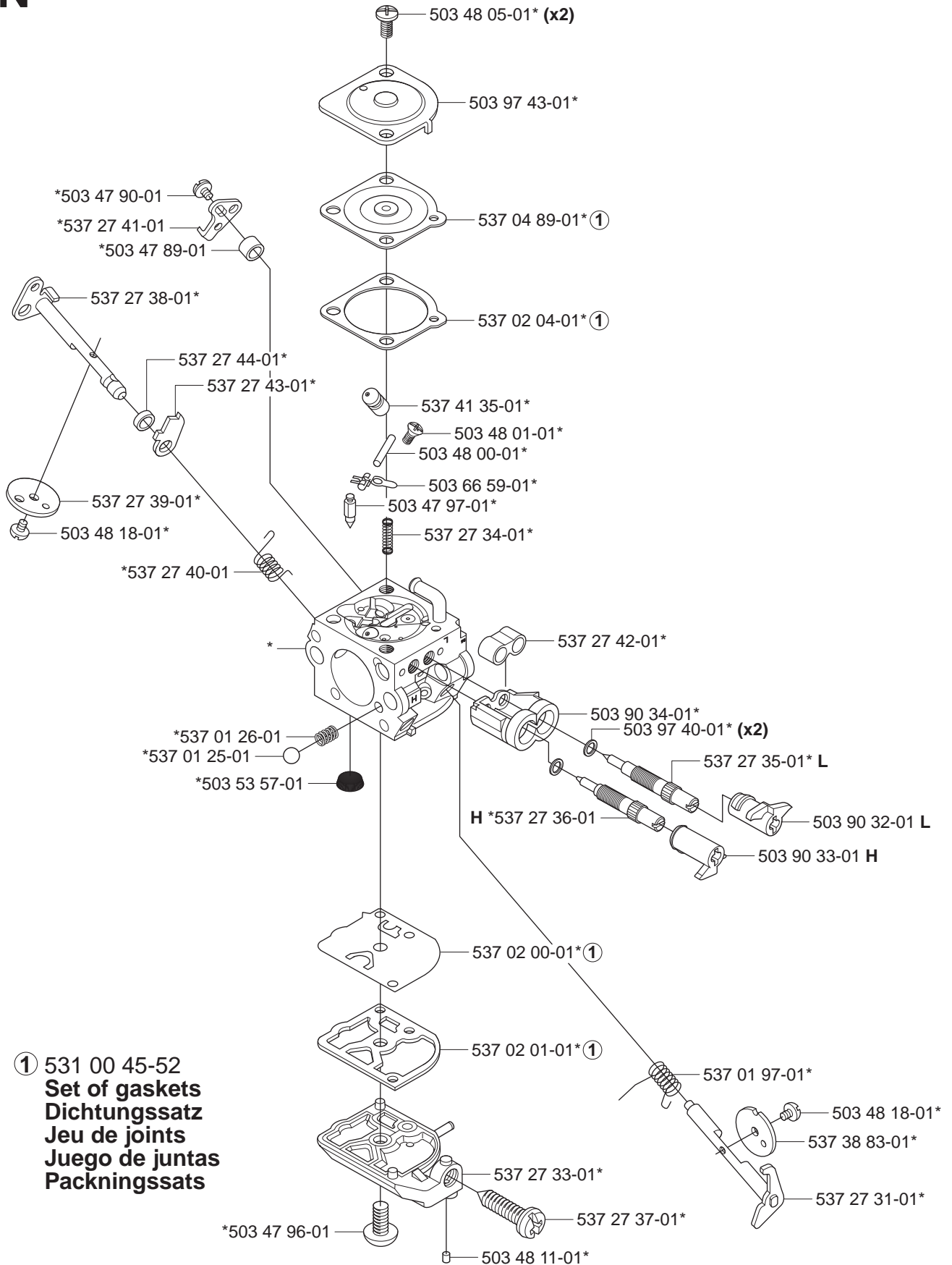
Zama C1Q-EL19B

① 531 00 45-52
Set of gaskets
Dichtungssatz
Jeu de joints
Juego de juntas
Packningsats

P Accessories
Zubehöre
Accessoires
Acessorios
Tillbehör

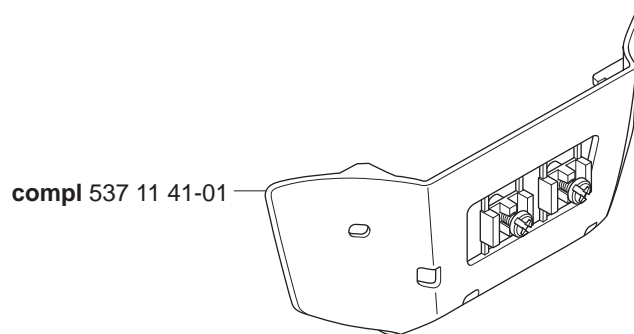
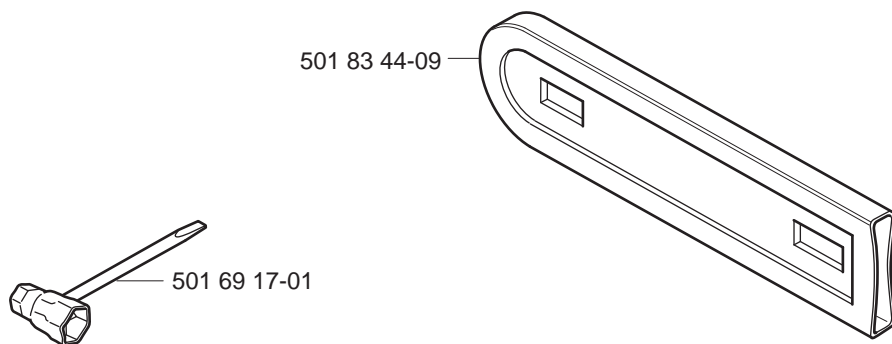

Q



*compl 537 40 98-01

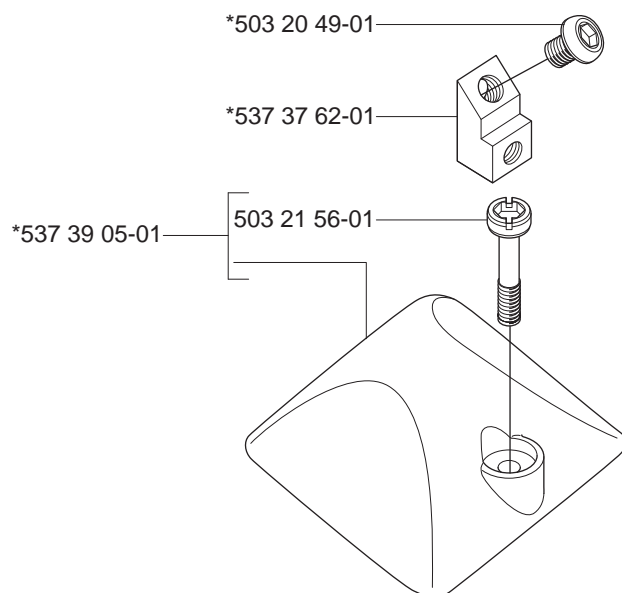

RECOMMENDED PARTS, ACCESSORIES, LUBRICANTS

338XPT CHAINSAW

	<u>Item</u>	<u>Part Number</u>	<u>Description</u>
Normal Maintenance Parts	Air Filter	537 02 15-02	
	Spark Plug	503 23 51-11	Clamshell Version 531 30 06-88
	Muffler Cover	503 81 14-02	
	Spark Plug Cover	537 39 05-01	
	Fuel Filter	503 44 32-01	
	Ignition Module	537 16 21-04	
	Starter Housing Assy.	503 79 25-01	
	Switch, Start/Stop & Choke	503 81 34-01	
	Front Handle	503 81 69-01	
	Chain Brake	503 93 52-03	
	Fuel Cap	537 21 52-04	Clamshell Version 531 30 03-56
	Oil Cap	537 21 52-02	
Bar Nut	503 22 00-01		
	<u>Item</u>	<u>Part Number</u>	<u>Description</u>
Chainsaw Accessories	Bar	501 95 92-52	14" Pro Bar (3/8"),(.050"), <i>Clamshell Version: 531 30 03-75</i>
	Chain	501 84 69-52	H36-52, 14" chain (3/8"),(.050"), <i>Clamshell Version: 531 30 03-72</i>
	Carrying Case	100 00 01-07	Powerbox Carrying Case with 20" Bar Protector
	Scrench	531 30 03-85	Standard combination bar nut wrench, spark plug wrench, and screwdriver
	File Kit	505 69 81-93	File Kit includes: File handle, Combination file guide, 2 round files, and 1 flat file. Use with H36 chain.
	<u>Item</u>	<u>Part Number</u>	<u>Description</u>
Lubricants	Bar and Chain	610 00 00-14	Bar and Chain Lubricant - 1 Quart
		610 00 00-34	Bar and Chain Lubricant - 1 Gallon
	2 Cycle Low Smoke Oil	610 00 00-85	2 Cycle Low Smoke Oil - 2.6 oz (1 Gallon Mix)
		610 00 00-82	2 Cycle Low Smoke Oil - 6.4 oz (2.5 Gallon Mix)
	<u>Item</u>	<u>Part Number</u>	<u>Description</u>
Protective Apparel	Protective Glasses	605 00 04-15	Lexa- Clear lens
		605 00 04-16	Lexa- Grey lens
	Helmets	505 67 53-15	Helmet System (Husqvarna)
	Protective Gloves	531 30 02-73	Xtreme Duty Work Gloves (Medium)
		531 30 02-74	Xtreme Duty Work Gloves (Large)
		531 30 02-75	Xtreme Duty Work Gloves (X-Large)
	Chaps	605 00 00-13	Pro Forest Apron Chaps (Navy Blue)
605 00 00-14		Pro Forest Apron Chaps (Orange)	

338XPT

Part Number	Description	Square	Part Number	Description	Square
501 45 27-02	NUT	L	503 85 51-01	PROTECTOR	A
501 45 41-01	PAWL	L	503 86 20-01	GUIDE	A
501 45 43-01	BOLT	L	503 86 38-01	PLATE	L
501 48 54-02	SPARK PLUG CONN. KIT	G	503 90 09-01	GROMMET	G
501 62 33-01	GUIDE BAR LOCATING PIN	L	503 90 32-01	LIMITER CAP	N
501 62 98-01	VALVE PLUG	M	503 90 33-01	LIMITER CAP	N
501 68 68-01	CHAIN CATCHER	L	503 90 34-01	SLEEVE	N
501 69 17-01	COMBI TOOL	P	503 90 83-01	SPRING	A
501 76 31-01	RECOIL SPRING	H	503 90 87-03	DECAL	H
501 81 92-01	SCREW	L	503 90 88-01	DECAL	A
501 82 25-01	FUEL INLET-FITTING	M	503 90 98-02	WASHER	G
501 83 44-09	BAR PROT/13-16"	P	503 92 42-01	COVER	N
501 87 53-01	KNEE-JOINT	A	503 92 96-01	SPRING	M
502 20 40-01	KNOB	C	503 93 03-03	MUFFLER	F
502 20 65-03	SCREW	C	503 93 52-03	CHAINBRAKE ASSEMBLY	A
503 14 51-01	CLUTCH SPRING	B	503 93 53-01	HAND GUARD	A
503 18 49-01	SPRING	L	503 93 66-01	AIR PURGE BUBBLE	M
503 20 02-16	SCREW	F	503 96 32-01	CABLE ASSY	M
503 20 02-16	SCREW	L,M	503 96 71-01	FILTER HOLDER	D
503 20 02-25	SCREW	L	503 96 72-01	AIR FILTER	D
503 20 02-40	SCREW	L	503 96 72-02	AIR FILTER	D
503 20 25-16	SCREW	G	503 96 75-01	OIL PLUMMET	M
503 20 49-01	SCREW	Q	503 97 40-01	WASHER	N
503 21 28-10	SCREW	A,M	503 97 43-01	COVER	N
503 21 56-01	SCREW	M,Q	503 97 81-02	WASHER	L
503 21 58-25	SCREW	E,H	503 97 82-01	SPRING	L
503 21 75-50	SCREW	D	503 98 13-01	PLUG	M
503 21 77-16	SCREW	H	503 98 62-01	GASKET	L
503 21 88-30	SCREW	M	503 98 74-01	DECAL	A
503 22 00-01	NUT M8 FLANGE	A	503 98 94-02	KIT	L
503 22 10-11	NUT M8X1	G	504 34 00-04	NIPPLE	J
503 23 00-16	WASHER 5.1X8.5	L	505 30 51-25	STARTER ROPE	H
503 23 51-08	SPARK PLUG RCJ7Y	J	530 02 61-19	VALVE-CHECK (DUCKBILL)	M
503 25 46-01	NEEDLE BEARING	B	531 00 45-52	GASKET KIT (ZAMA GND39)	N
503 26 30-17	O-RING	M	537 00 84-01	STARTER HANDLE	H
503 28 34-04	CARBURETOR	D,N	537 01 25-01	BALL	N
503 28 90-03	PISTON RING	J	537 01 26-01	SPRING	N
503 41 41-01	NEEDLE BEARING	J,K	537 01 97-01	SPRING THROTTLE	N
503 44 32-01	FUEL FILTER	M	537 02 00-01	PUMP DIAPHRAGM	N
503 47 89-01	SPACER	N	537 02 01-01	GASKET	N
503 47 90-01	SCREW	N	537 02 04-01	GASKET	N
503 47 96-01	SCREW	N	537 02 15-02	AIR FILTER	D
503 47 97-01	INLET NEEDLE	N	537 04 24-08	HOSE	M
503 48 00-01	PIN FULLCRUM	N	537 04 24-09	HOSE	M
503 48 01-01	SCREW	N	537 04 61-01	NIPPLE	L
503 48 05-01	SCREW	N	537 04 89-01	DIAPHRAGM	N
503 48 11-01	PLUG	N	537 05 28-01	SLEEVE	M
503 48 18-01	SCREW	N	537 05 68-01	SCREW	L
503 52 12-04	WASHER	B	537 09 28-01	SPRING	A
503 53 57-01	STRAINER	N	537 10 04-01	GASKET	J
503 55 22-01	CYLINDER PLUG	J	537 10 65-01	CHAIN TENSIONER KIT	L
503 57 76-02	HOSE	M	537 11 32-03	HOSE ASSY	J
503 57 89-01	HOLDER	M	537 11 41-01	WINTER SET	P
503 60 04-01	FILTER PLUG	M	537 12 68-06	VALVE DECOMPR	J
503 66 59-01	LEVER	N	537 13 27-01	PISTON	J
503 71 02-03	PAWL	G	537 15 77-01	PIPE	J
503 71 40-03	CLUTCH	B	537 16 21-04	IGNITION MODULE	G
503 72 31-01	BUSHING	L	537 16 73-01	CLAMP	J
503 73 58-01	FUEL TANK BUSHING	M	537 18 00-01	PROTECTIVE CAP	J
503 78 92-01	PINION	L	537 20 19-01	STARTER PULLEY	H
503 79 05-02	RIVET	G	537 21 52-02	TANK CAP	M
503 79 22-04	CRANKCASE	L	537 21 52-04	TANK CAP LIGHT GRAY	M
503 79 25-01	STARTER HOUSING ASSY.	H	537 24 19-01	SEALING	D
503 79 26-02	COVER	C	537 24 95-04	FUEL TANK	M
503 80 52-01	COVER	A	537 27 31-01	SHAFT	N
503 80 83-02	PUMP PISTON	L	537 27 33-01	COVER	N
503 80 97-02	BRAKE BAND	A	537 27 34-01	SPRING	N
503 81 14-02	COVER	E	537 27 35-01	LOW SPEED NEEDLE	N
503 81 32-01	TRIGGER	M	537 27 36-01	NEEDLE HIGH SPEED	N
503 81 34-01	SWITCH, START/STOP & CHOKE	M	537 27 37-01	SCREW	N
503 81 35-01	PLATE	M	537 27 38-01	SHAFT	N
503 81 69-01	HANDLE	M	537 27 39-01	WASHER	N
503 81 71-01	SHAFT PIVOT	A	537 27 40-01	SPRING	N
503 81 73-01	FELLING DOG	L	537 27 41-01	ARM	N
503 81 81-01	SPRING	G	537 27 42-01	SLEEVE	N
503 81 85-01	STARTER HOUSING	H	537 27 43-01	ARM	N
503 82 09-02	COVER	C	537 27 44-01	WASHER	N
503 82 11-01	GASKET	J	537 37 62-01	NUT	Q
503 82 17-01	SCREEN	F	537 39 05-01	SPARK PLUG COVER	M,Q
503 82 22-71	CLUTCH DRUM	B	537 40 98-01	REAR END FIX KIT	Q
503 82 27-02	CHOKE ROD	M	720 12 33-00	PIN 3X10	A
503 82 28-01	ROD	M	720 12 40-20	PIN 3X25	M
503 82 33-02	VIBRATION ABSORBER	M	720 12 46-20	PIN	M
503 84 26-01	HOSE	M	724 12 87-59	SCREW	F
503 84 27-01	FOAM INSULATOR	L	729 56 55-01	SCREW	M
503 85 13-01	SPRING	M	735 31 08-20	E-RING 4	A
503 85 38-04	ANTI-VIBE ELEMENT	M	735 31 10-20	C-WASHER	A
503 85 46-01	PIN	A	737 44 10-00	LOCKING RING	J