

## K650 Cut-n-Break

Reservdelar

Spare parts

Ersatzteile

Pieces de rechange

Piezas de repuesto

Ricambi

Peças sobresselente

No.	Pos.	Description	No.	Pos.	Description
501 00 88-01	B	SCREW	503 53 40-01	N	CONNECTOR ELBOW
501 00 88-02	B	SCREW	503 55 22-01	E	PLUG
501 22 02-01	N	WELCH PLUG(SMALL)	503 57 86-01	N	SPEED SCREW RET BALL
501 22 03-01	N	WELCH PLUG(LARGE)	503 57 87-01	N	IDLE SPEED SCREW
501 22 04-01	N	CHOKE FRICTION BALL	503 57 89-01	D	TANK CAP
501 22 05-01	N	SPRING	503 65 27-01	N	SCREW SHUTTER
501 22 08-01	N	DIAPHRAGM GASKET	503 65 30-01	N	WASHER
501 22 09-01	N	DIAPHRAGM	503 65 31-01	N	THROTTLE SH.WASHER
501 22 12-01	N	FUEL PUMP DIAPHRAM	503 71 53-01	E	DECOMPRESSION VALVE
501 22 13-01	N	FUEL PUMP GASKET	503 74 43-01	C	CLUTCH SPRING
501 22 14-01	N	FUEL PUMP COVER	503 74 44-04	C	CLUTCH ASSY
501 22 15-01	N	SCREW	503 77 98-01	N	CHECKVALVE ASSY
501 22 20-01	N	LEVER	503 89 16-01	G	SPRING
501 22 21-01	N	PIN RETAINING SCREW	503 98 82-01	N	SCREEN
501 22 25-01	N	SPRING	504 03 68-01	L	CYLINDER COVER
501 42 71-01	N	CHOKE SHAFT SLEEVE	504 13 92-01	L	FILTER BOTTOM
501 48 52-01	N	PIN RETAINING SCREW	504 14 25-01	A	BEARING CAGE KIT
501 48 54-02	K	SPARK PLUG CAP	504 35 72-01	D	SINTER PLUG
501 49 48-02	N	DIAPHRAGM SET	505 22 09-37	D	BAR BOLT
501 63 48-01	K	SPRING	505 26 76-73	G	SPACING SLEEVE
501 67 32-03	K	PAWL	505 26 94-27	G	THROTTLE ROD
501 69 17-02	P	COMBINATION TOOL	505 27 75-16	K	ISOLERHATT
501 76 83-04	D	FUEL HOSE	505 27 90-60	M	INSULATING FLANGE
501 76 83-26	D	FUEL HOSE	505 27 95-13	H	DAMPING PIECE
501 81 99-01	K	SCREW	505 29 56-14	G	TORSION SPRING
501 82 18-01	N	"THROTTLE SH.""E""RING"	505 30 23-33	EF	NEEDLE BEARING
503 12 79-01	J	STARTER HANDLE	505 30 24-15	C	NEEDLE BEARING
503 15 59-04	G	CONSOLE	505 31 61-14	N	THROTTLE FLAP
503 20 00-01	GH	SCREW COLLAR	505 31 64-95	N	THROTTLE SH.QUADRING
503 20 00-02	AG	SCREW COLLAR	505 31 65-50	N	INLET NEEDLE
503 20 00-03	L	SCREW COLLAR	505 31 66-05	N	THROTTLE SH. SPRING
503 20 00-04	H	SCREW COLLAR	505 31 66-19	N	THROTTLE SH.&LEVER
503 20 00-05	E	SCREW COLLAR	506 03 99-01	H	REINFORCEMENT STAY
503 20 00-05	H	SCREW COLLAR	506 07 11-13	D	TANK VENT ASSY
503 20 00-07	D	SCREW COLLAR	506 09 56-05	A	HOSE CLAMP
503 20 00-08	DGH	SCREW COLLAR	506 09 56-06	H	HOSE CLAMP
503 20 00-09	G	SCREW COLLAR	506 09 64-01	DEMP	GASKET
503 20 00-10	G	SCREW COLLAR	506 09 75-02	H	HOSE
503 20 00-35	H	SCREW COLLAR	506 14 42-01	H	GROUND SUPPORT
503 20 00-44	G	SCREW COLLAR	506 21 79-02	L	FILTER COVER
503 20 00-47	E	SCREW COLLAR	506 21 86-02	K	FLYWHEEL ASSY
503 20 02-90	L	SCREW	506 21 89-03	J	STARTER HOUSING
503 20 21-75	M	SCREW	506 21 90-02	J	AIR CONDUCTOR
503 20 25-20	K	SCREW	506 21 91-01	D	GROMMET
503 20 34-19	CJ	SCREW	506 21 98-01	L	LUFTMUNSTYCKE C-REN.
503 20 34-25	J	SCREW	506 22 23-01	L	SEALING
503 20 34-42	L	SCREW	506 22 24-01	L	SEALING
503 21 27-16	CH	SCREW	506 22 42-02	L	AIR FILTER PAPER
503 21 28-10	AGJ	SCREW	506 22 44-01	G	GUIDE CHOKE CONTROL
503 21 67-22	J	SCREW	506 22 45-01	G	CHOKE CONTROL
503 21 88-74	H	SCREW	506 22 47-03	G	SWITCH
503 22 04-01	K	NUT	506 22 48-01	G	CABLE HOLDER
503 22 65-04	GH	NUT	506 22 63-01	L	PREFILTER
503 23 00-11	G	WASHER STEEL	506 23 61-01	D	TANK VENT
503 23 00-42	KM	WASHER STEEL	506 23 83-01	N	CHOKE
503 23 00-73	C	WASHER STEEL	506 23 93-02	L	LABEL
503 23 04-03	B	WASHER	506 24 37-14	E	CYLINDER ASSY
503 23 51-09	K	SPARK PLUG	506 25 14-01	J	GROMMET
503 25 00-01	DF	BALL BEARING	506 25 30-01	J	COMPRESSION SPRING
503 26 02-04	DEMP	SEALING RING	506 25 59-03	D	TANK CAP ASSY
503 26 30-08	A	O-RING	506 25 61-01	D	FUEL TANK
503 26 30-21	H	O-RING	506 25 81-02	J	STARTER PULLEY
503 26 60-02	H	COUPLER	506 25 82-01	L	INTERMEDIATE WALL
503 28 04-18	MN	CARBURETTOR	506 25 89-01	J	RECOIL SPRING
503 28 90-17	E	PISTON RING	506 25 95-03	J	STARTER
503 40 13-04	G	CONSOLE	506 26 28-01	G	COMPRESSION SPRING
503 40 17-01	G	CONTACT PLATE	506 26 30-02	G	SWITCH
503 41 18-02	GK	CABLE	506 26 31-01	J	SPACING SLEEVE
503 44 31-01	DEMP	GASKET CRANKCASE	506 26 41-01	D	FUEL FILTER
503 49 10-01	DEMP	GASKET	506 26 41-11	D	FUEL FILTER

No.	Pos.	Description	No.	Pos.	Description
506 26 85-01	M	SEALING	531 15 59-01	B	CUTTING BLADE
506 27 11-01	D	HOSE CLAMP	531 15 59-02	B	CUTTING BLADE
506 27 14-01	N	MET.RETENTION SCREW	544 01 88-01	K	IGNITION SYSTEM
506 27 56-01	N	CHOKE SHAFT & LEVER	544 03 21-02	H	SPRAY GUARD
506 27 57-01	N	SEAL CHOKE SHAFT	544 03 22-01	H	PLATE
506 27 61-01	N	RETAINER	544 03 92-01	H	BUSHING
506 28 39-03	L	ELASTIC STRING	544 04 17-02	A	HOSE
506 29 21-01	D	GASKET	544 10 37-03	A	BAR
506 29 57-03	H	NIPPLE	544 10 47-04	H	SPRAY GUARD
506 29 65-02	H	VIB.INSULATOR	544 10 48-04	C	CLUTCH COVER
506 31 15-01	N	INSERT	544 10 50-04	A	HOSE
506 31 61-01	N	DIAPHRAGM	544 10 52-04	A	CUTTER ARM
506 31 74-01	D	THREAD BUSHING	544 10 57-03	A	BEARING CAGE
506 31 88-01	M	INLET BEND	544 10 59-01	A	BEARING
506 32 02-01	DEMP	GASKET	544 10 93-04	D	CRANKCASE
506 32 03-01	DEMP	GASKET	544 11 10-04	H	HANDLE
506 32 12-01	N	REPAIR PARTS KIT	544 17 80-02	P	TOOL
506 32 15-03	M	CARBURETTOR	544 26 53-01	B	WASHER
506 33 16-01	C	SUPPORT RING	544 37 44-02	A	LABEL
506 33 56-15	J	STARTER CORD	544 37 45-02	C	LABEL
506 34 06-01	DEMP	GASKET	544 37 46-02	L	LABEL
506 34 07-01	E	COOLING PLATE	544 38 42-02	DEMP	GASKET KIT
506 34 56-02	D	COVER	544 39 32-01	G	HOSE CLIP
506 34 74-21	A	BELT	544 87 44-02	L	LABEL
506 35 08-05	G	HANDLE HALF RIGHT	544 87 44-04	L	LABEL
506 35 10-01	F	CRANKSHAFT ASSY	544 87 44-05	L	LABEL
506 35 27-02	A	PROTECTIVE SPRING	544 87 46-02	L	LABEL
506 36 80-01	D	SPACER	544 89 53-01	H	RESTRICTION
506 38 08-14	E	MUFFLER	544 89 65-02	L	LABEL
506 38 46-02	E	PISTON ASSY	544 91 30-01	J	LABEL
506 38 59-05	H	HOSE	544 92 69-01	G	THROTTLE CONTROL
506 38 60-04	H	VALVE ASSY	544 92 70-01	G	THROTTLE LOCKOUT
506 38 69-01	G	VIB.DAMPER ASSY	720 13 07-10	D	PIN
506 38 78-34	K	IGNITION CABLE	721 42 58-20	G	PIN
506 38 87-02	G	WEIGHT	724 12 84-01	A	SCREW
506 38 88-02	G	WEIGHT	725 52 95-55	L	SCREW
506 38 89-02	G	GROUND SUPPORT	731 23 18-01	C	NUT
506 39 48-02	G	HANDLE HALF	732 21 14-01	H	LOCK NUT
506 39 49-02	G	WEIGHT	735 31 08-20	C	E-RING
506 40 24-01	B	CENTRE NUT	735 31 10-41	B	CIRCLIP
506 40 25-01	B	SCREW	735 58 18-00	G	LOCK WASHER
506 40 26-01	C	SCREW	735 88 06-00	F	WOODRUFF KEY
506 40 28-02	A	BEARING CAGE	737 43 12-00	E	CIRCLIP
506 40 29-02	A	BUSHING	740 42 01-00	M	O-RING
506 40 32-01	C	GEAR WHEEL	740 42 05-00	H	O-RING
506 40 33-01	C	BELT TENSIONER	740 43 13-00	J	O-RING
506 40 34-01	C	PAWL	740 48 07-03	C	O-RING
506 40 35-01	H	HANDLE			
506 40 35-02	H	HANDLE			
506 40 37-01	H	BUSHING			
506 40 46-02	A	WEAR PROTECTION			
506 40 50-02	A	BELT GUARD			
506 40 51-01	A	STOP			
506 40 53-01	A	BAR			
506 40 54-02	C	CLUTCH COVER			
506 40 55-02	A	BELT GUARD			
506 40 56-01	A	DEFLECTION LIMITER			
506 40 56-02	A	DEFLECTION LIMITER			
506 40 57-02	A	GROMMET			
506 40 58-01	A	NIPPLE			
506 40 59-01	A	SEALING			
506 40 60-01	H	SPRING			
506 40 61-01	A	SPRING			
506 40 61-02	A	SPRING			
506 40 62-02	H	SPRAY GUARD			
506 40 63-02	H	SPRAY GUARD			
506 40 64-02	A	BLADE GUARD			
506 40 65-02	A	BLADE GUARD			
506 40 98-02	A	NIPPLE			
531 15 59-00	B	CUTTING BLADE			

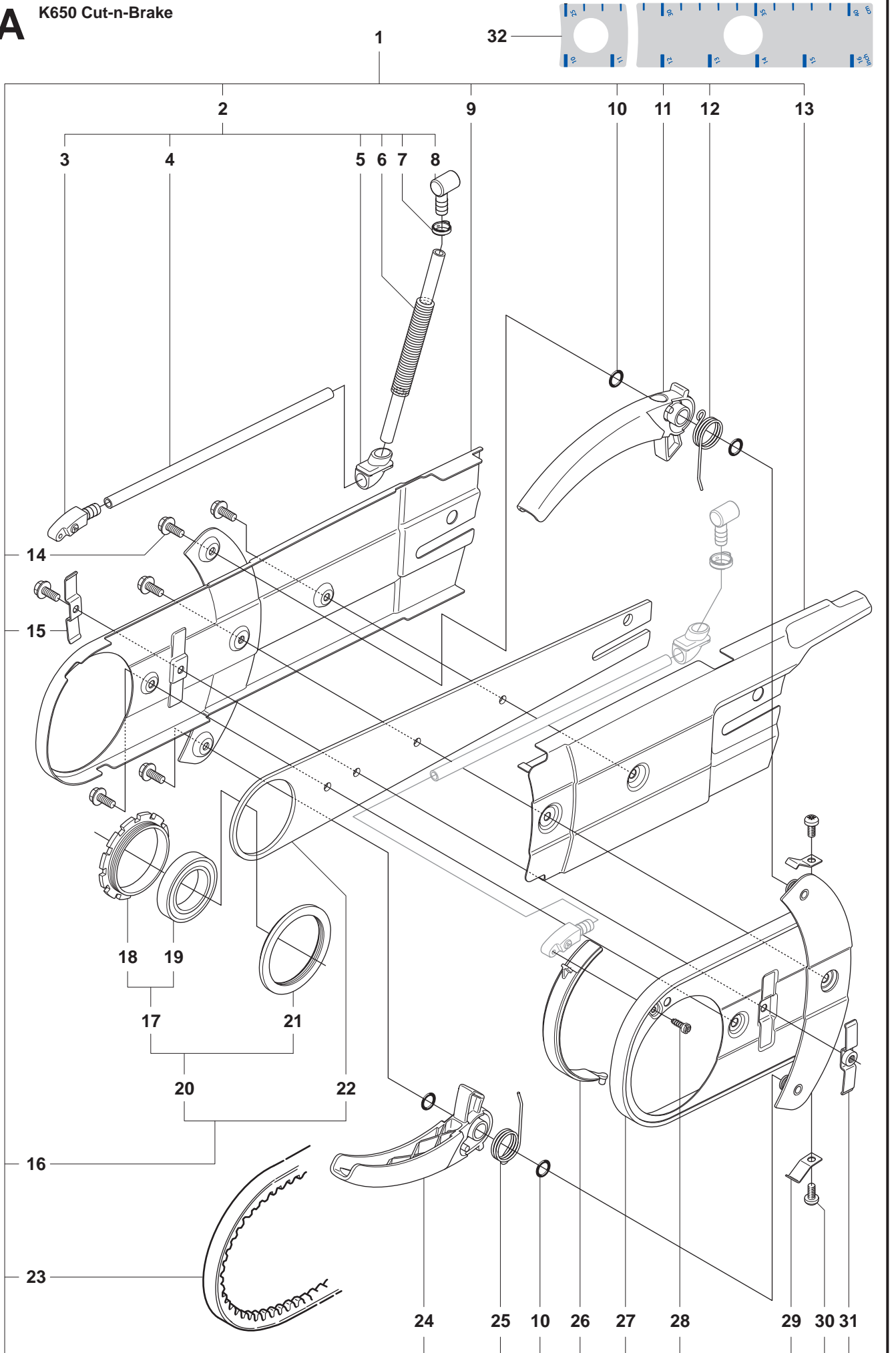
**A****K650 Cut-n-Brake**

**Page A**  
**K650 Cut-n-Break**

Pos.	Part No.	Description	Quantity	Notes
1	544 10 52-04	CUTTER ARM	1	Incl. 2, 9 - 16, 23 - 31
2	544 10 50-04	HOSE	1	Incl. 3 - 7
3	506 40 58-01	NIPPLE	1	
4	544 04 17-02	HOSE	1	
5	506 40 57-02	GROMMET	1	
6	506 35 27-02	PROTECTIVE SPRING	1	
7	506 09 56-05	HOSE CLAMP	1	
8	506 40 98-02	NIPPLE	1	
9	506 40 55-02	BELT GUARD	1	
10	503 26 30-08	O-RING	2	
11	506 40 64-02	BLADE GUARD	1	
12	506 40 61-01	SPRING	1	
13	506 40 50-02	BELT GUARD	1	
14	503 20 00-02	SCREW COLLAR	6	
15	506 40 56-01	DEFLECTION LIMITER	1	
16	544 10 37-03	BAR	1	Incl. 20, 22
17	544 10 57-03	BEARING CAGE	1	Incl. 18, 19
18	506 40 28-02	BEARING CAGE	1	
19	544 10 59-01	BEARING	1	
20	504 14 25-01	BEARING CAGE KIT	1	Incl. 17, 21
21	506 40 29-02	BUSHING	1	
22	506 40 53-01	BAR	1	
23	506 34 74-21	BELT	1	
24	506 40 65-02	BLADE GUARD	1	
25	506 40 61-02	SPRING	1	
26	506 40 59-01	SEALING	1	
27	506 40 46-02	WEAR PROTECTION	1	
28	503 21 28-10	SCREW	1	
29	506 40 51-01	STOP	2	
30	724 12 84-01	SCREW	2	
31	506 40 56-02	DEFLECTION LIMITER	1	
32	544 37 44-02	LABEL	1	

**B** K650 Cut-n-Brake

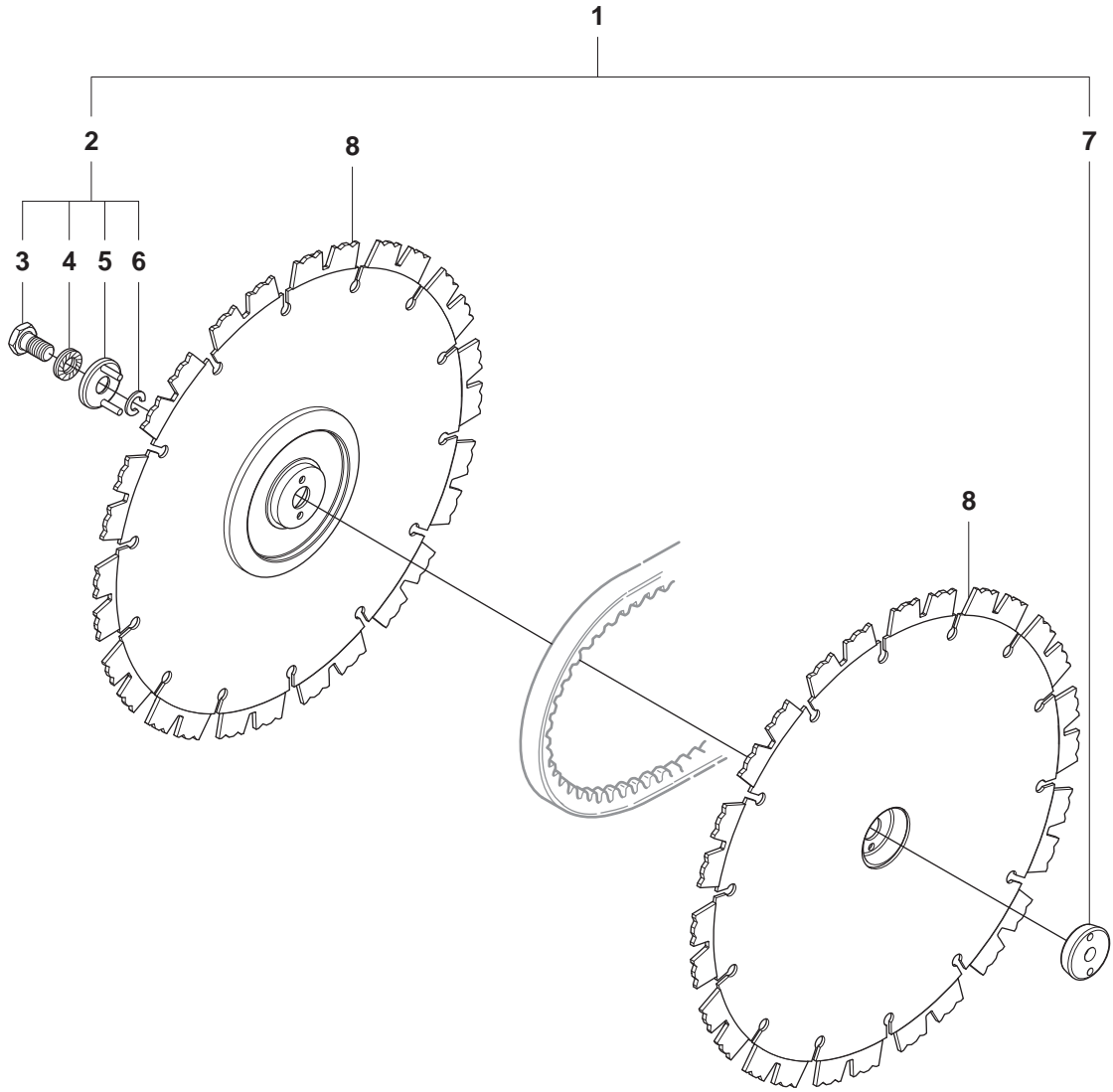

**Page B**  
**K650 Cut-n-Break**

<b>Pos.</b>	<b>Part No.</b>	<b>Description</b>	<b>Quantity</b>	<b>Notes</b>
1	501 00 88-02	SCREW	1	Incl. 2, 7
2	501 00 88-01	SCREW	1	
3	506 40 25-01	SCREW	1	
4	503 23 04-03	WASHER	1	
5	544 26 53-01	WASHER	1	
6	735 31 10-41	CIRCLIP	1	
7	506 40 24-01	CENTRE NUT	1	
8	531 15 59-00	CUTTING BLADE	2	EL20CB Soft
8	531 15 59-01	CUTTING BLADE	2	EL45CB Medium
8	531 15 59-02	CUTTING BLADE	2	EL70CB Hard

**C** K650 Cut-n-Brake

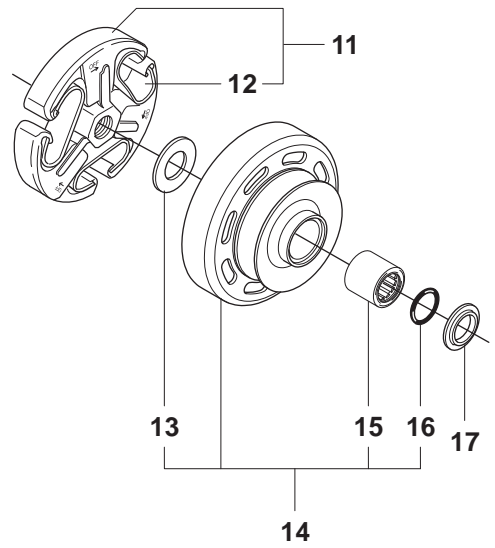
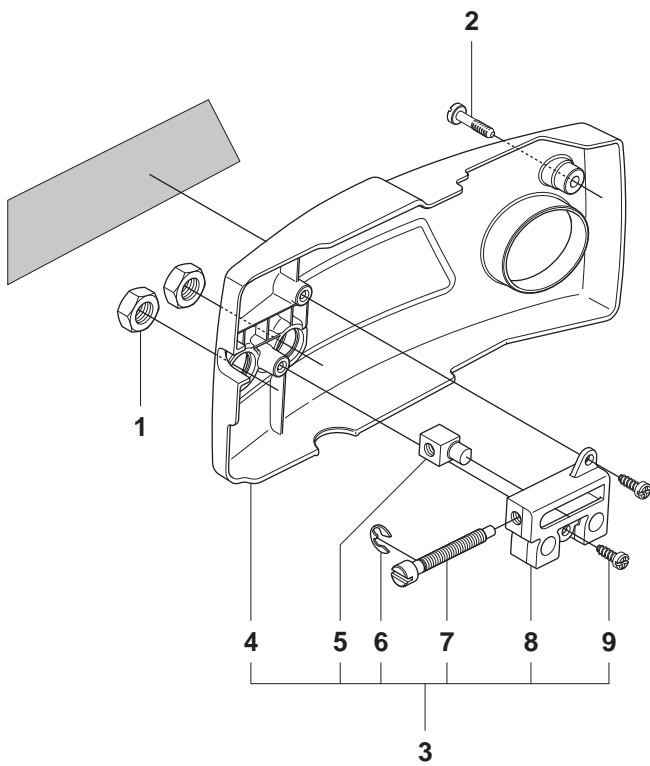



**Page C**  
**K650 Cut-n-Break**

Pos.	Part No.	Description	Quantity	Notes
1	731 23 18-01	NUT	2	
2	503 20 34-19	SCREW	1	
3	544 10 48-04	CLUTCH COVER	1	Incl. 4 - 9
4	506 40 54-02	CLUTCH COVER	1	
5	506 40 34-01	PAWL	1	
6	735 31 08-20	E-RING	1	
7	506 40 26-01	SCREW	1	
8	506 40 33-01	BELT TENSIONER	1	
9	503 21 27-16	SCREW	2	
10	544 37 45-02	LABEL	1	
11	503 74 44-04	CLUTCH ASSY	1	Incl. 12
12	503 74 43-01	CLUTCH SPRING	3	
13	503 23 00-73	WASHER STEEL	1	
14	506 40 32-01	GEAR WHEEL	1	Incl. 13, 15, 16
15	505 30 24-15	NEEDLE BEARING	1	
16	740 48 07-03	O-RING	1	
17	506 33 16-01	SUPPORT RING	1	

# D K650 Cut-n-Brake

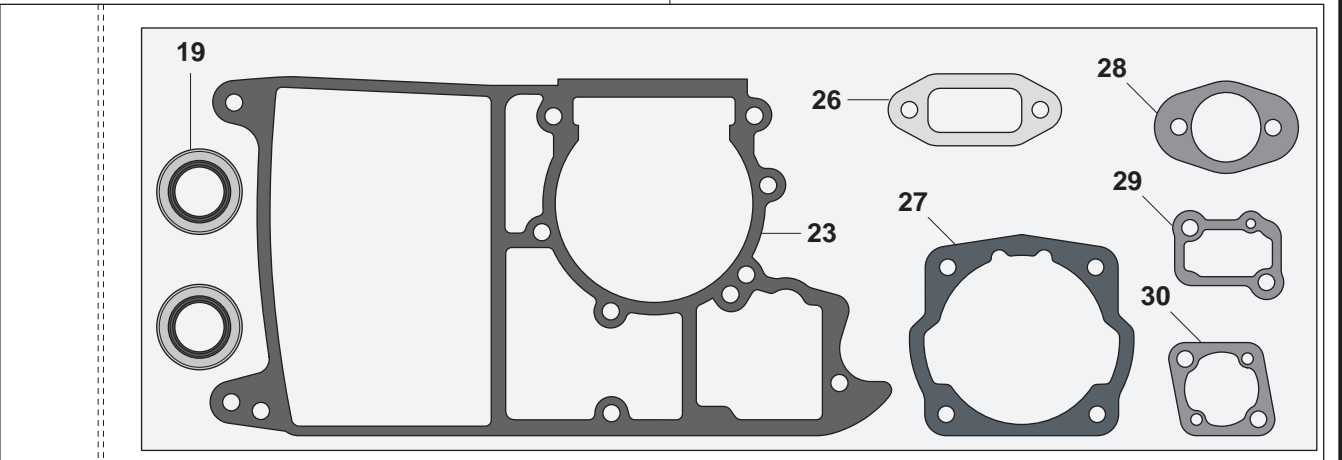
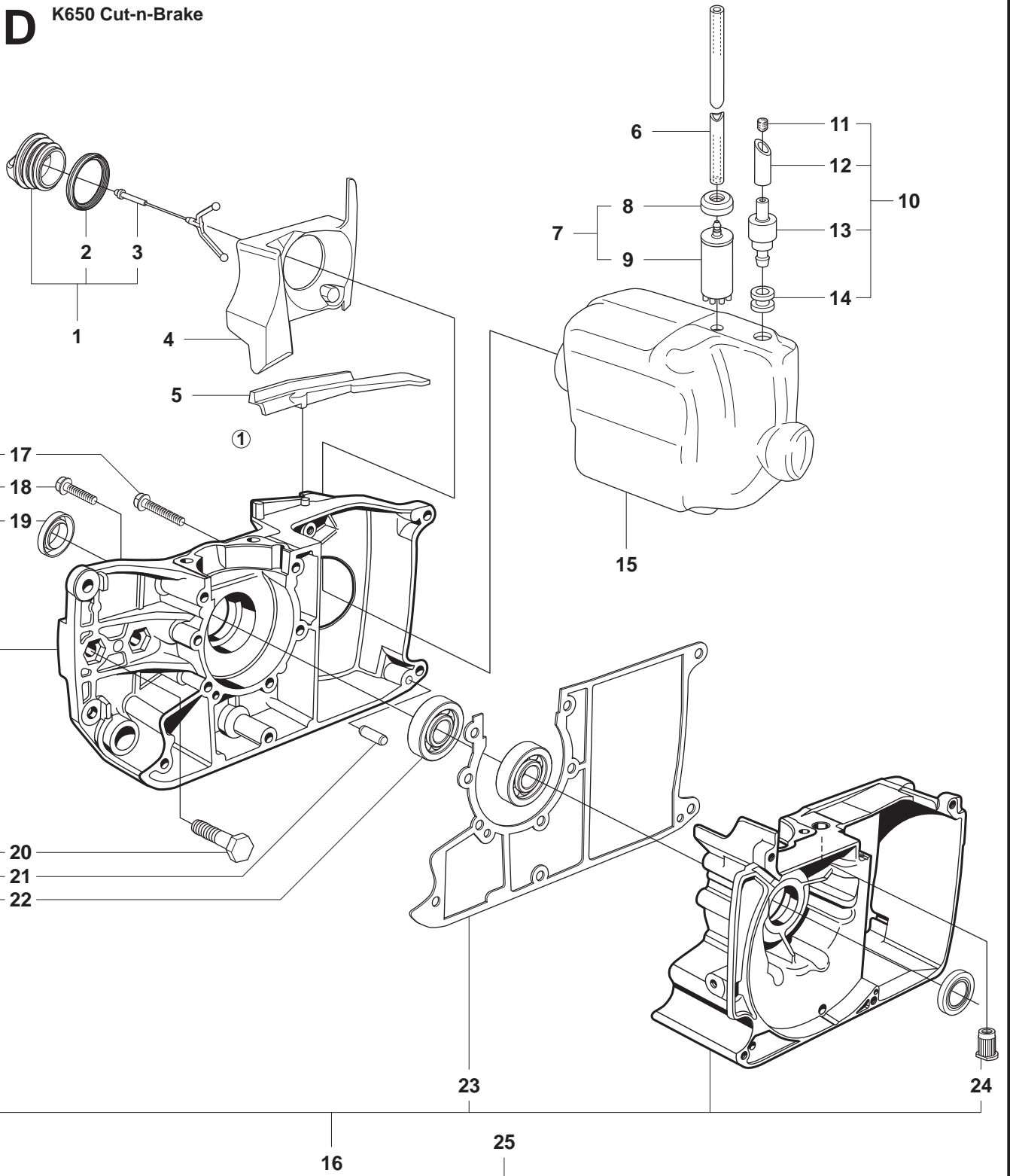

**Page D**  
**K650 Cut-n-Break**

Pos.	Part No.	Description	Quantity	Notes
1	506 25 59-03	TANK CAP ASSY	1	Incl. 2, 3
2	506 29 21-01	GASKET	1	
3	503 57 89-01	TANK CAP	1	
4	506 34 56-02	COVER	1	
5	506 36 80-01	SPACER	1	
6	501 76 83-26	FUEL HOSE	1	
7	506 26 41-11	FUEL FILTER	1	Incl. 8, 9
8	506 27 11-01	HOSE CLAMP	1	
9	506 26 41-01	FUEL FILTER	1	
10	506 07 11-13	TANK VENT ASSY	1	Incl. 11 - 14
11	504 35 72-01	SINTER PLUG	1	
12	501 76 83-04	FUEL HOSE	1	
13	506 23 61-01	TANK VENT	1	
14	506 21 91-01	GROMMET	1	
15	506 25 61-01	FUEL TANK	1	
16	544 10 93-04	CRANKCASE	1	Incl. 17 - 24
17	503 20 00-07	SCREW COLLAR	3	
18	503 20 00-08	SCREW COLLAR	4	
19	503 26 02-04	SEALING RING	2	Gasket kit 25
20	505 22 09-37	BAR BOLT	2	
21	720 13 07-10	PIN	2	
22	503 25 00-01	BALL BEARING	2	
23	503 44 31-01	GASKET CRANKCASE	1	Gasket kit 25
24	506 31 74-01	THREAD BUSHING	1	
25	544 38 42-02	GASKET KIT	1	Incl. 19, 23, 26 - 30
26	506 34 06-01	GASKET	1	
27	503 49 10-01	GASKET	1	
28	506 09 64-01	GASKET	1	
29	506 32 03-01	GASKET	1	
30	506 32 02-01	GASKET	1	

**E** K650 Cut-n-Brake

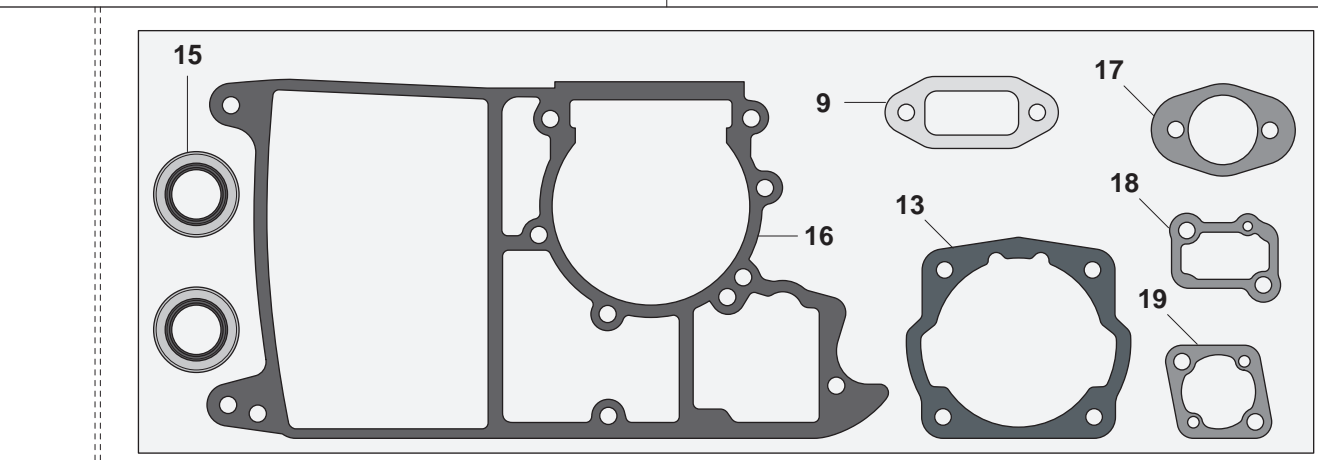
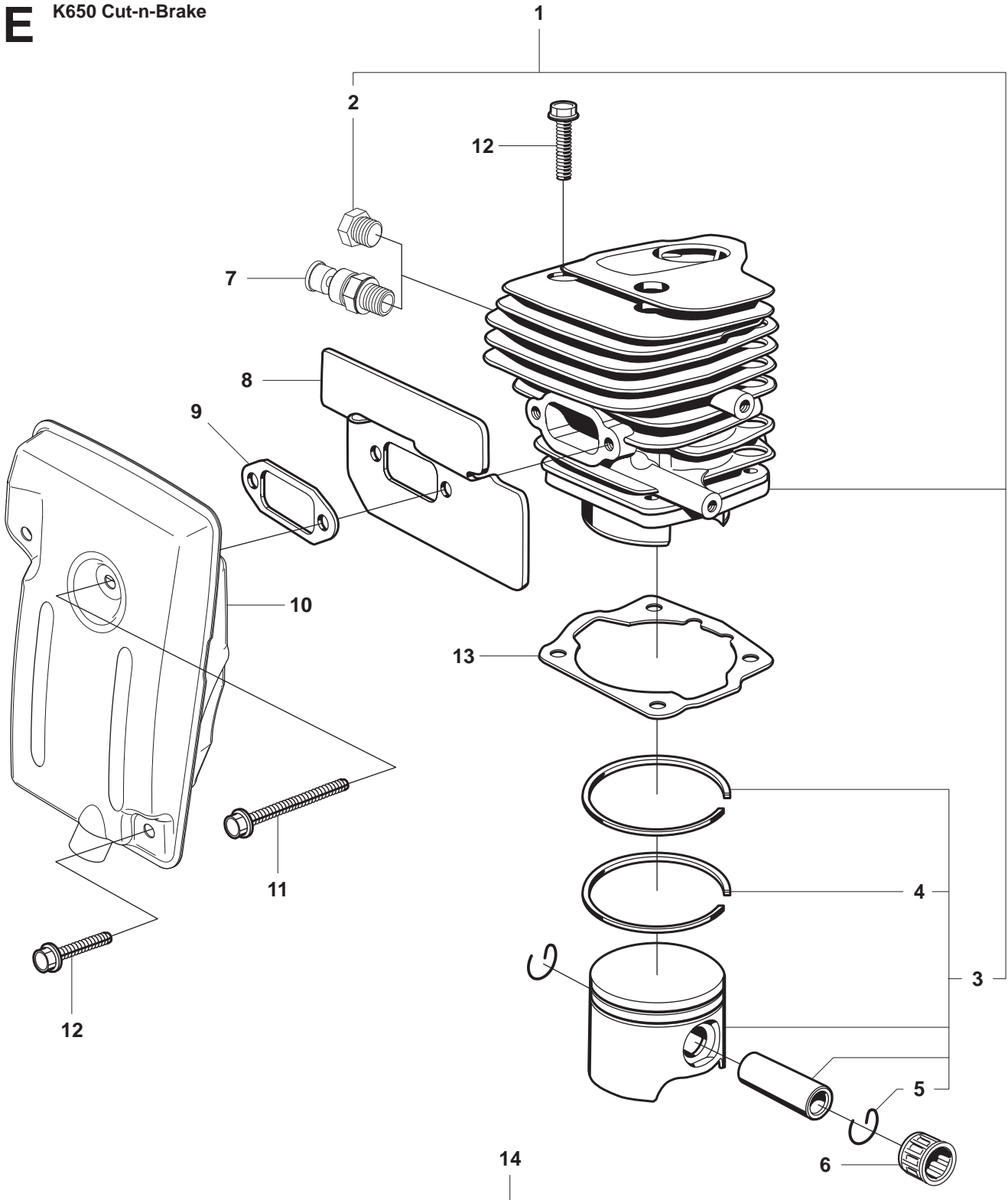

**Page E**  
**K650 Cut-n-Break**

Pos.	Part No.	Description	Quantity	Notes
1	506 24 37-14	CYLINDER ASSY	1	Incl. 2, 3
2	503 55 22-01	PLUG	1	
3	506 38 46-02	PISTON ASSY	1	Incl. 4, 5
4	503 28 90-17	PISTON RING	2	
5	737 43 12-00	CIRCLIP	2	
6	505 30 23-33	NEEDLE BEARING	1	
7	503 71 53-01	DECOMPRESSION VALVE	1	
8	506 34 07-01	COOLING PLATE	1	
9	506 34 06-01	GASKET	1	Gasket kit 14
10	506 38 08-14	MUFFLER	1	
11	503 20 00-47	SCREW COLLAR	2	
12	503 20 00-05	SCREW COLLAR	5	
13	503 49 10-01	GASKET	1	Gasket kit 14
14	544 38 42-02	GASKET KIT	1	Incl. 9, 13, 15 - 19
15	503 26 02-04	SEALING RING	2	
16	503 44 31-01	GASKET CRANKCASE	1	
17	506 09 64-01	GASKET	1	
18	506 32 03-01	GASKET	1	
19	506 32 02-01	GASKET	1	

**F** K650 Cut-n-Brake

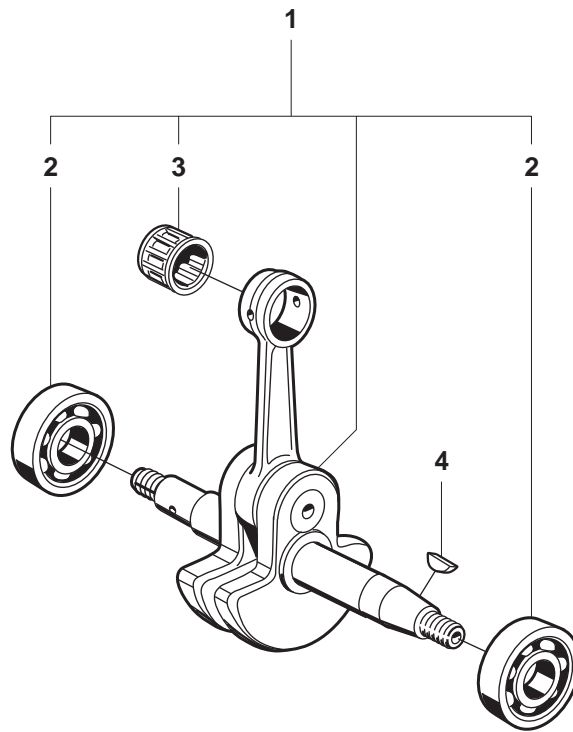

**Page F**

**K650 Cut-n-Break**

<b>Pos.</b>	<b>Part No.</b>	<b>Description</b>	<b>Quantity</b>	<b>Notes</b>
1	506 35 10-01	CRANKSHAFT ASSY	1	Incl. 2, 3
2	503 25 00-01	BALL BEARING	2	
3	505 30 23-33	NEEDLE BEARING	1	
4	735 88 06-00	WOODRUFF KEY	1	

**G** K650 Cut-n-Brake

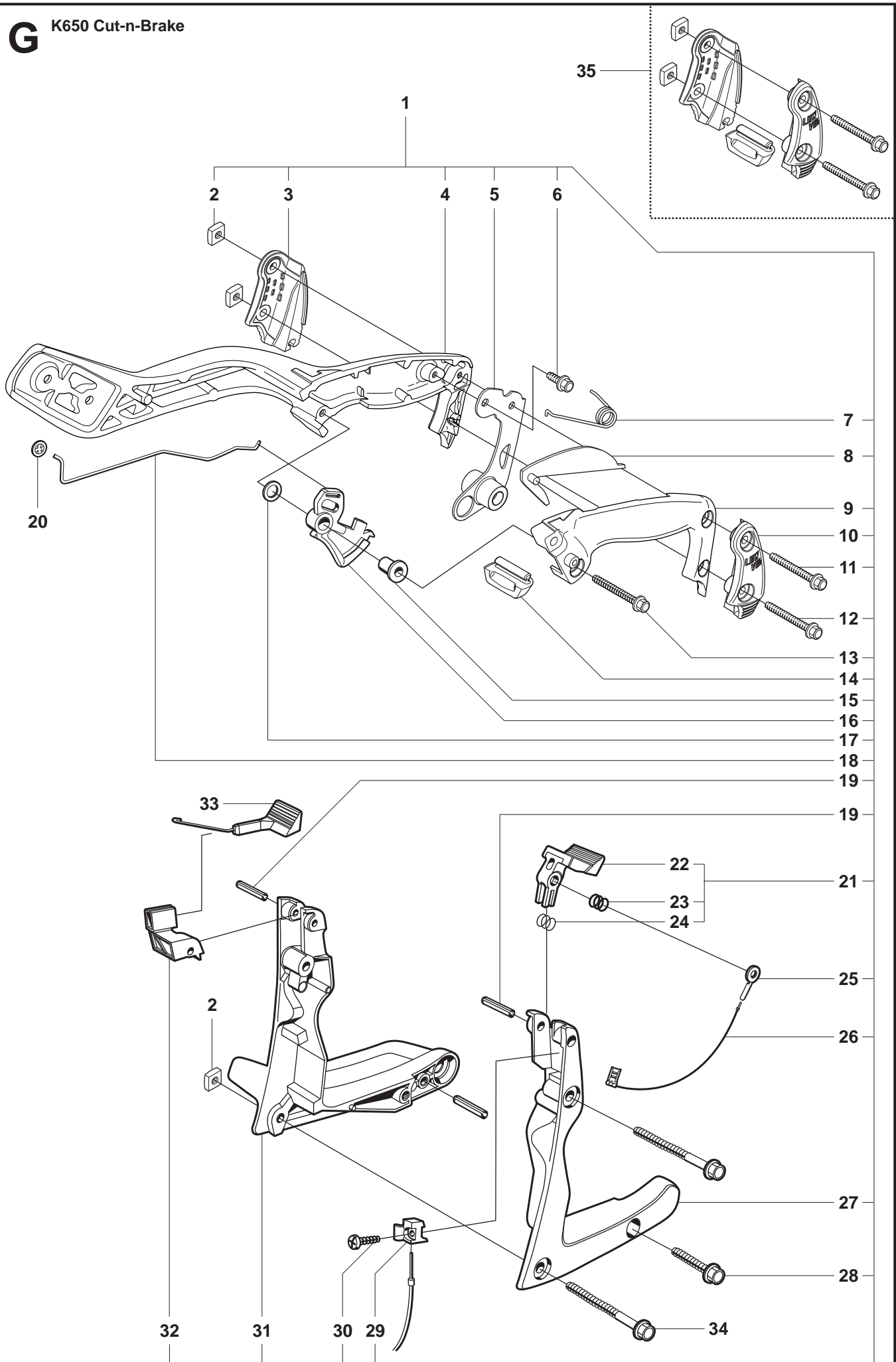



**Page G**  
**K650 Cut-n-Break**

Pos.	Part No.	Description	Quantity	Notes
1	544 39 32-01	HOSE CLIP	1	Incl. 2 - 19, 21, 25 - 32
2	503 22 65-04	NUT	4	
3	506 38 87-02	WEIGHT	1	
4	506 35 08-05	HANDLE HALF RIGHT	1	
5	506 38 69-01	VIB.DAMPER ASSY	1	
6	503 20 00-02	SCREW COLLAR	1	
7	505 29 56-14	TORSION SPRING	1	
8	544 92 70-01	THROTTLE LOCKOUT	1	
9	506 39 48-02	HANDLE HALF	1	
10	506 38 88-02	WEIGHT	1	
11	503 20 00-44	SCREW COLLAR	1	
12	503 20 00-09	SCREW COLLAR	1	
13	503 20 00-08	SCREW COLLAR	1	
14	506 38 89-02	GROUND SUPPORT	1	
15	505 26 76-73	SPACING SLEEVE	1	
16	544 92 69-01	THROTTLE CONTROL	1	
17	503 23 00-11	WASHER STEEL	1	
18	505 26 94-27	THROTTLE ROD	1	
19	721 42 58-20	PIN	3	
20	735 58 18-00	LOCK WASHER	1	
21	506 26 30-02	SWITCH	1	Incl. 22, 23, 24
22	506 22 47-03	SWITCH	1	
23	506 26 28-01	COMPRESSION SPRING	1	
24	503 89 16-01	SPRING	1	
25	503 40 17-01	CONTACT PLATE	1	
26	503 41 18-02	CABLE	1	
27	503 40 13-04	CONSOLE	1	
28	503 20 00-01	SCREW COLLAR	1	
29	506 22 48-01	CABLE HOLDER	1	
30	503 21 28-10	SCREW CCRPANT	1	
31	503 15 59-04	CONSOLE	1	
32	506 22 44-01	GUIDE CHOKE CONTROL	1	
33	506 22 45-01	CHOKE CONTROL	1	
34	503 20 00-10	SCREW COLLAR	2	
35	506 39 49-02	WEIGHT	1	

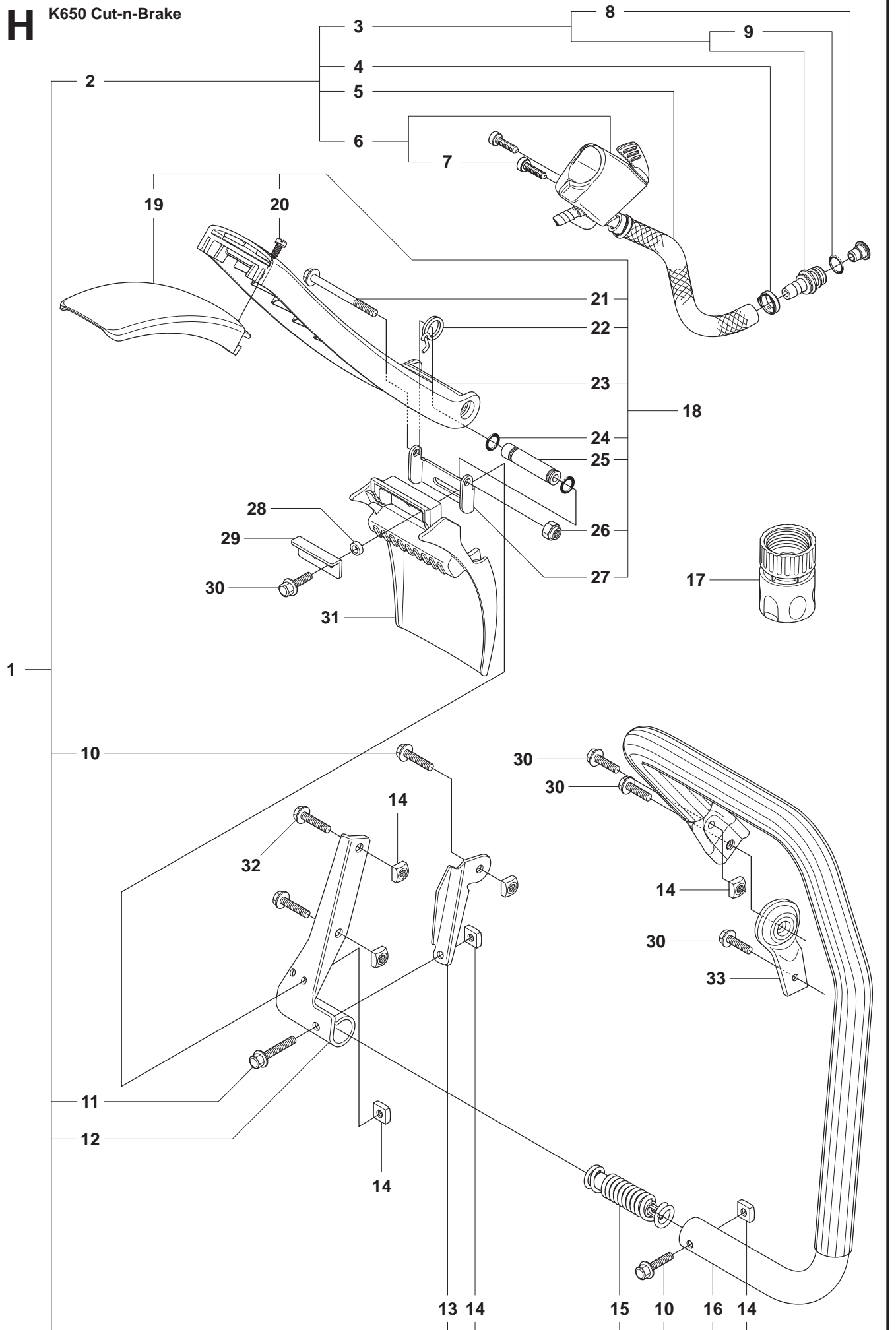
**H****K650 Cut-n-Brake**

**Page H**  
**K650 Cut-n-Break**

Pos.	Part No.	Description	Quantity	Notes
1	544 11 10-04	HANDLE	1	Incl. 2, 10 - 16
2	506 38 59-05	HOSE	1	
3	506 29 57-03	NIPPLE	1	Incl. 8
4	506 09 56-06	HOSE CLAMP	2	
5	506 09 75-02	HOSE	1	L=280mm
6	506 38 60-04	VALVE ASSY	1	Incl. 7
7	503 21 88-74	SCREW	2	
8	544 89 53-01	RESTRICTION	1	
9	503 26 30-21	O-RING	1	
10	503 20 00-05	SCREW COLLAR	1	
11	503 20 00-08	SCREW COLLAR	1	
12	506 14 42-01	GROUND SUPPORT	1	
13	506 03 99-01	REINFORCEMENT STAY	1	
14	503 22 65-04	NUT	6	
15	505 27 95-13	DAMPING PIECE	1	
16	506 40 35-02	HANDLE	1	
17	503 26 60-02	COUPLER	1	
18	544 10 47-04	SPRAY GUARD	1	Incl. 19 - 27
19	506 40 62-02	SPRAY GUARD	1	
20	503 21 27-16	SCREW	2	
21	503 20 00-01	SCREW COLLAR	1	
22	506 40 60-01	SPRING	1	
23	506 40 63-02	SPRAY GUARD	1	
24	740 42 05-00	O-RING	2	
25	506 40 37-01	BUSHING	1	
26	732 21 14-01	LOCK NUT	1	
27	506 40 35-01	HANDLE	1	
28	544 03 92-01	BUSHING	2	
29	544 03 22-01	PLATE	1	
30	503 20 00-04	SCREW COLLAR	2	
31	544 03 21-02	SPRAY GUARD	1	
32	503 20 00-35	SCREW COLLAR	2	
33	506 29 65-02	VIB.INSULATOR	1	

# J K650 Cut-n-Brake

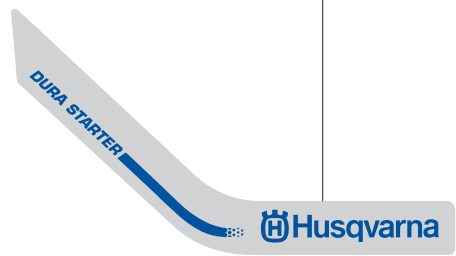
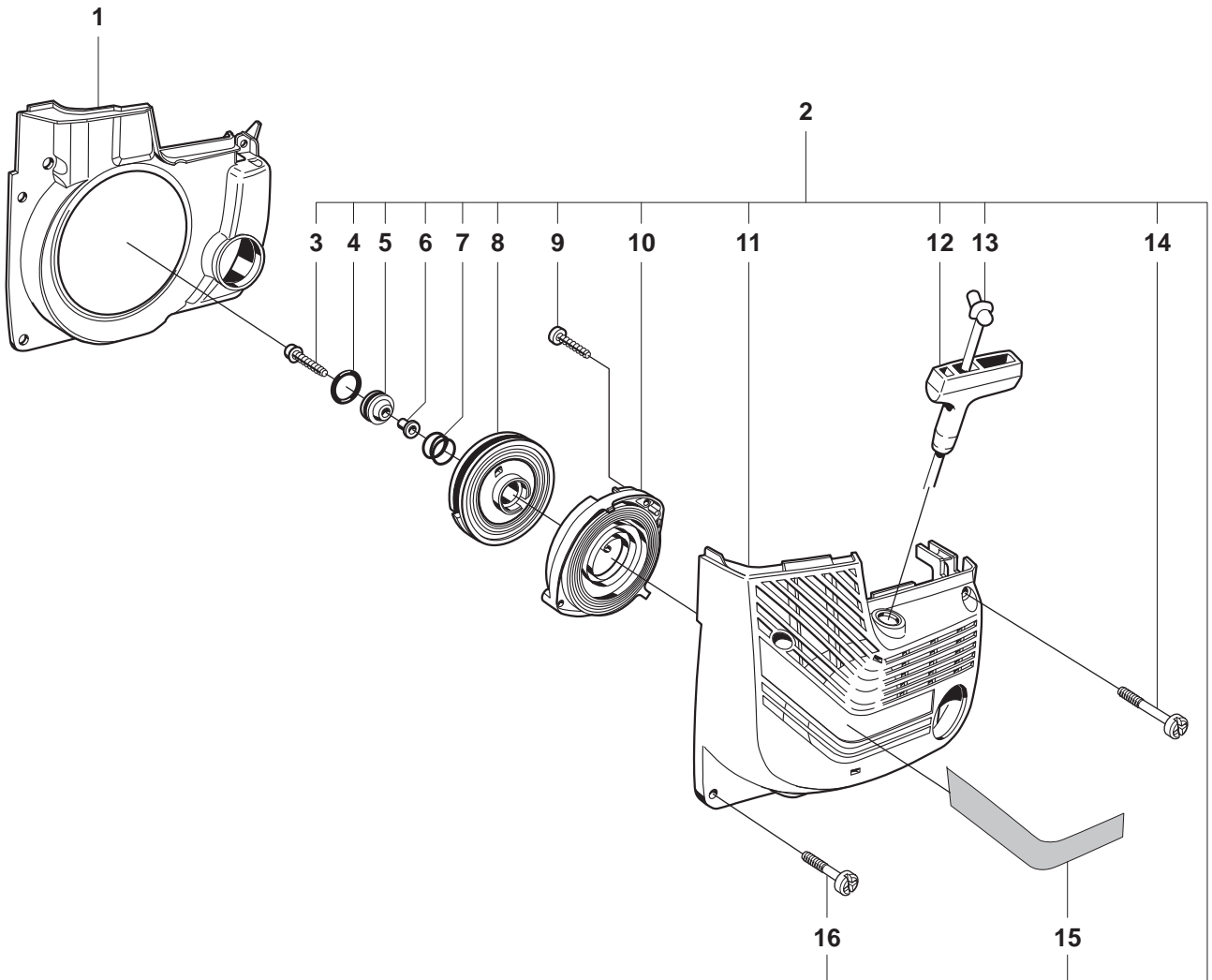

**Page J****K650 Cut-n-Break**

<b>Pos.</b>	<b>Part No.</b>	<b>Description</b>	<b>Quantity</b>	<b>Notes</b>
12	503 12 79-01	STARTER HANDLE	1	
1	506 21 90-02	AIR CONDUCTOR	1	
2	506 25 95-03	STARTER	1	Incl. 3 - 16
3	503 21 67-22	SCREW	1	
4	740 43 13-00	O-RING	1	
5	506 25 14-01	GROMMET	1	
6	506 26 31-01	SPACING SLEEVE	1	
7	506 25 30-01	COMPRESSION SPRING	1	
8	506 25 81-02	STARTER PULLEY	1	
9	503 21 28-10	SCREW	2	
10	506 25 89-01	RECOIL SPRING	1	
11	506 21 89-03	STARTER HOUSING	1	
13	506 33 56-15	STARTER CORD	1	
14	503 20 34-25	SCREW	2	
15	544 91 30-01	LABEL	1	
16	503 20 34-19	SCREW	2	

**K** K650 Cut-n-Brake

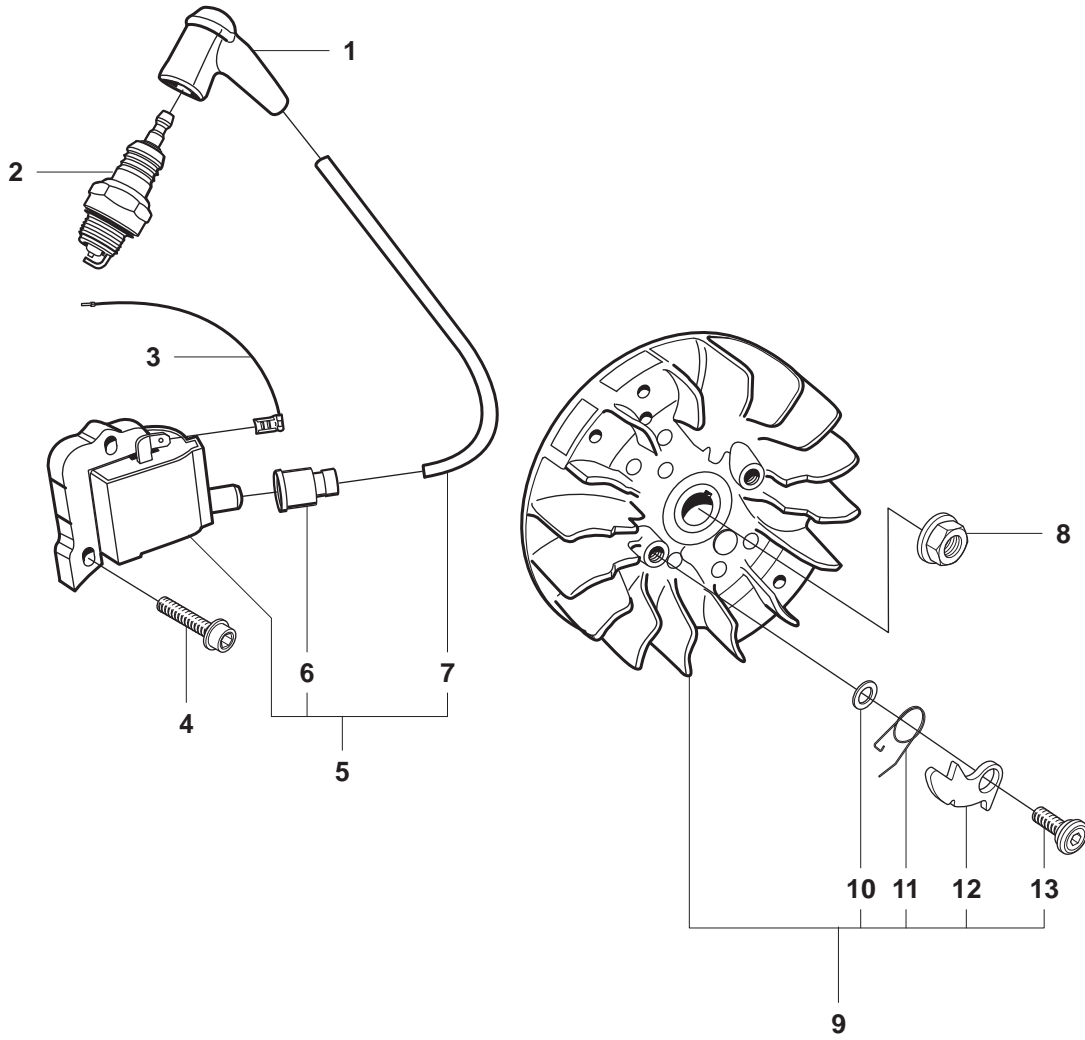

**Page K**  
**K650 Cut-n-Break**

<b>Pos.</b>	<b>Part No.</b>	<b>Description</b>	<b>Quantity</b>	<b>Notes</b>
1	501 48 54-02	SPARK PLUG CAP	1	
2	503 23 51-09	SPARK PLUG	1	RCJ6Y
3	503 41 18-02	CABLE	1	
4	503 20 25-20	SCREW	2	
5	544 01 88-01	IGNITION SYSTEM	1	Incl. 6, 7
6	505 27 75-16	ISOLERHATT	1	
7	506 38 78-34	IGNITION CABLE	1	340mm
8	503 22 04-01	NUT	1	
9	506 21 86-02	FLYWHEEL ASSY	1	Incl. 10 - 13
10	503 23 00-42	WASHER STEEL	2	
11	501 63 48-01	SPRING	2	
12	501 67 32-03	PAWL	2	
13	501 81 99-01	SCREW	2	

# K650 Cut-n-Brake

**Note!**  
Excessive water can result in back-siphon!

**Decompression Valve**  
Push before starting

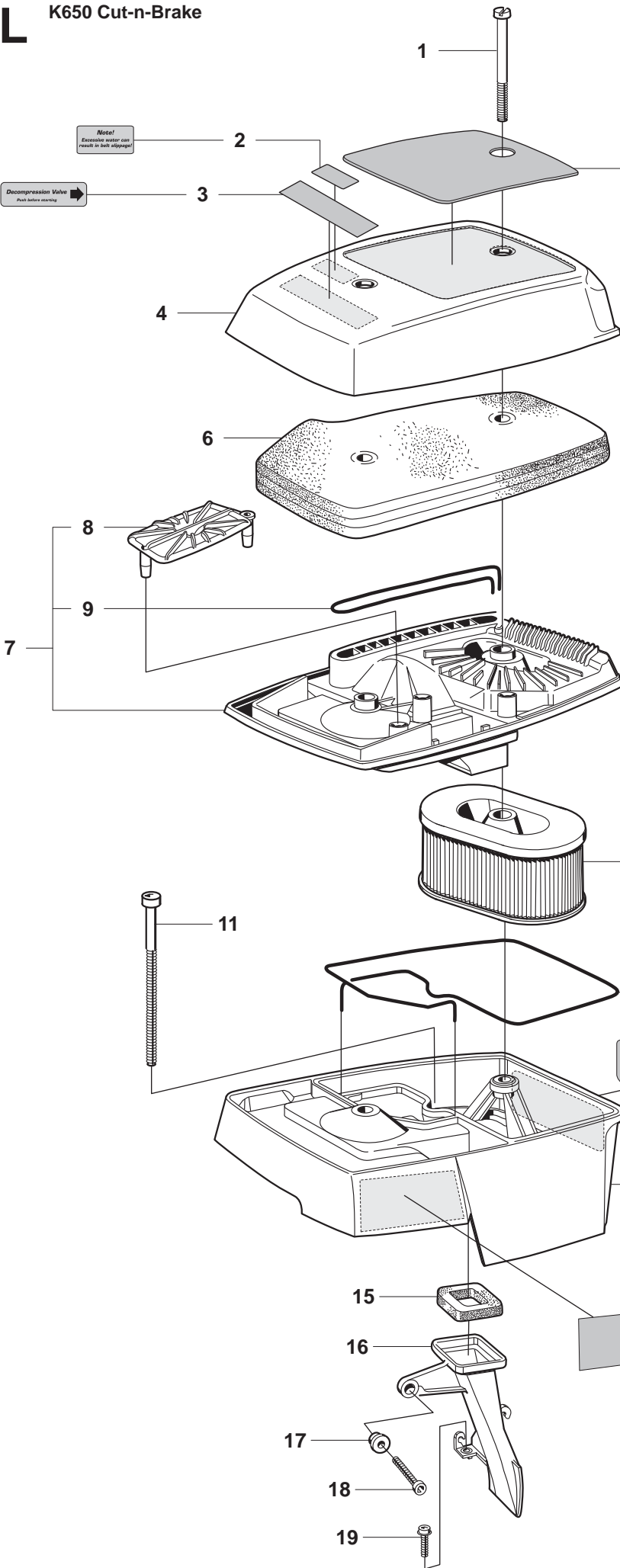



**Page L****K650 Cut-n-Break**

Pos.	Part No.	Description	Quantity	Notes
1	503 20 34-42	SCREW	1	
2	544 89 65-02	LABEL	1	
3	544 87 46-02	LABEL	1	
4	506 21 79-02	FILTER COVER	1	
5	544 87 44-02	LABEL	1	CE
5	544 87 44-04	LABEL	1	EPA USA
5	544 87 44-05	LABEL	1	EPA Canada
6	506 22 63-01	PREFILTER	1	
7	504 13 92-01	FILTER BOTTOM	1	Incl. 8, 9
8	506 25 82-01	INTERMEDIATE WALL	1	
9	506 28 39-03	ELASTIC STRING	2	
10	506 22 42-02	AIR FILTER PAPER	1	
11	503 20 02-90	SCREW	1	
12	504 03 68-01	CYLINDER COVER	1	Incl. 9, 13
13	506 23 93-02	LABEL	1	
14	544 37 46-02	LABEL	1	
15	506 22 23-01	SEALING	1	
16	506 21 98-01	LUFTMUNSTYCKE C-REN.	1	
17	506 22 24-01	SEALING	1	
18	725 52 95-55	SCREW	1	
19	503 20 00-03	SCREW COLLAR	1	

**M** K650 Cut-n-Brake

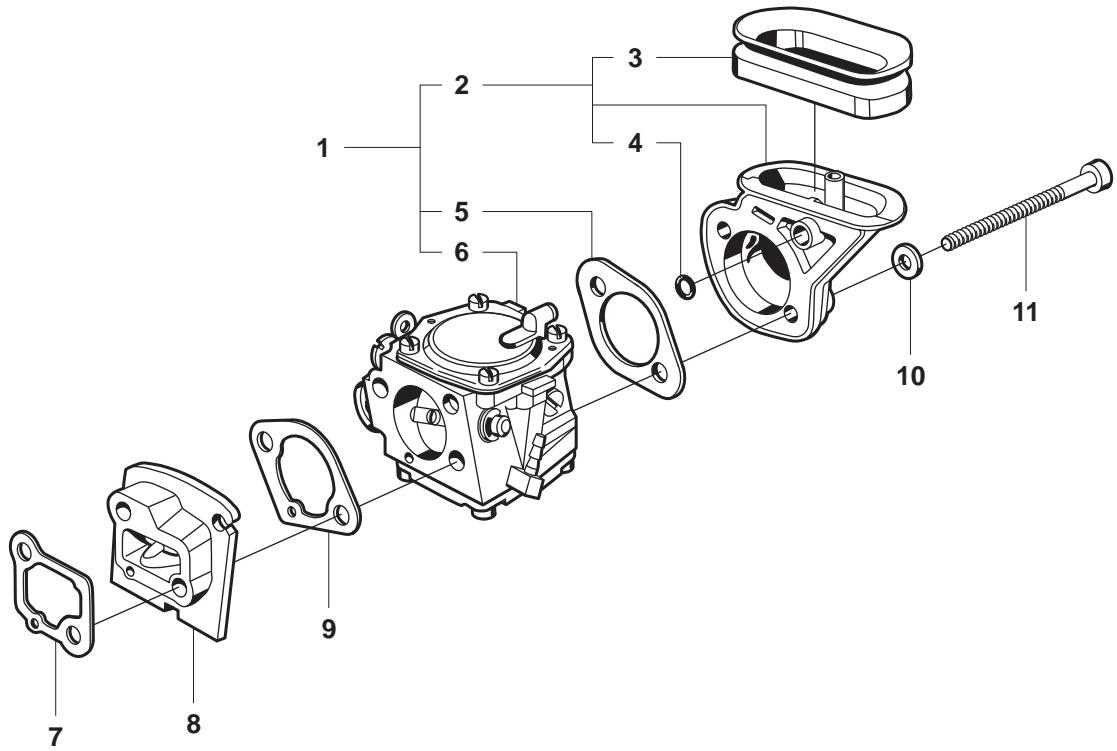

12

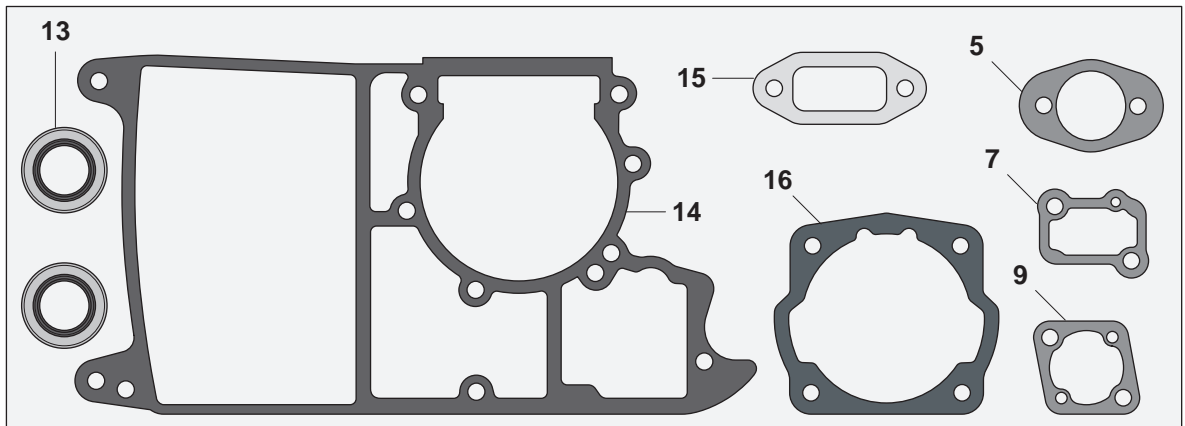

**Page M****K650 Cut-n-Break**

<b>Pos.</b>	<b>Part No.</b>	<b>Description</b>	<b>Quantity</b>	<b>Notes</b>
1	506 32 15-03	CARBURETTOR	1	Incl. 2, 5, 6
2	506 31 88-01	INLET BEND	1	Incl. 3, 4
3	506 26 85-01	SEALING	1	
4	740 42 01-00	O-RING	1	
5	506 09 64-01	GASKET	1	Gasket Kit 12
6	503 28 04-18	CARBURETTOR	1	Tillotson HS 175N
7	506 32 03-01	GASKET	1	Gasket Kit 12
8	505 27 90-60	INSULATING FLANGE	1	506 32 02-01
9	506 32 02-01	GASKET	1	Gasket Kit 12
10	503 23 00-42	WASHER STEEL	2	
11	503 20 21-75	SCREW	2	
12	544 38 42-02	GASKET KIT	1	
13	503 26 02-04	SEALING RING	2	
14	503 44 31-01	GASKET CRANKCASE	1	
15	506 34 06-01	GASKET	1	
16	503 49 10-01	GASKET	1	

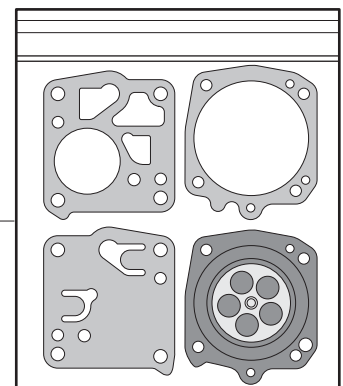
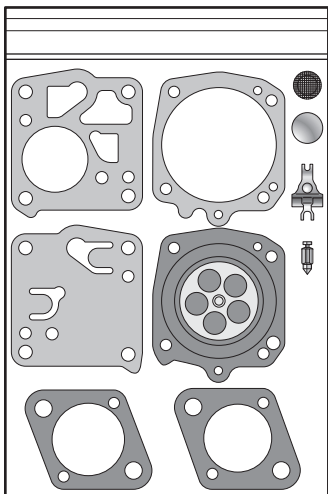
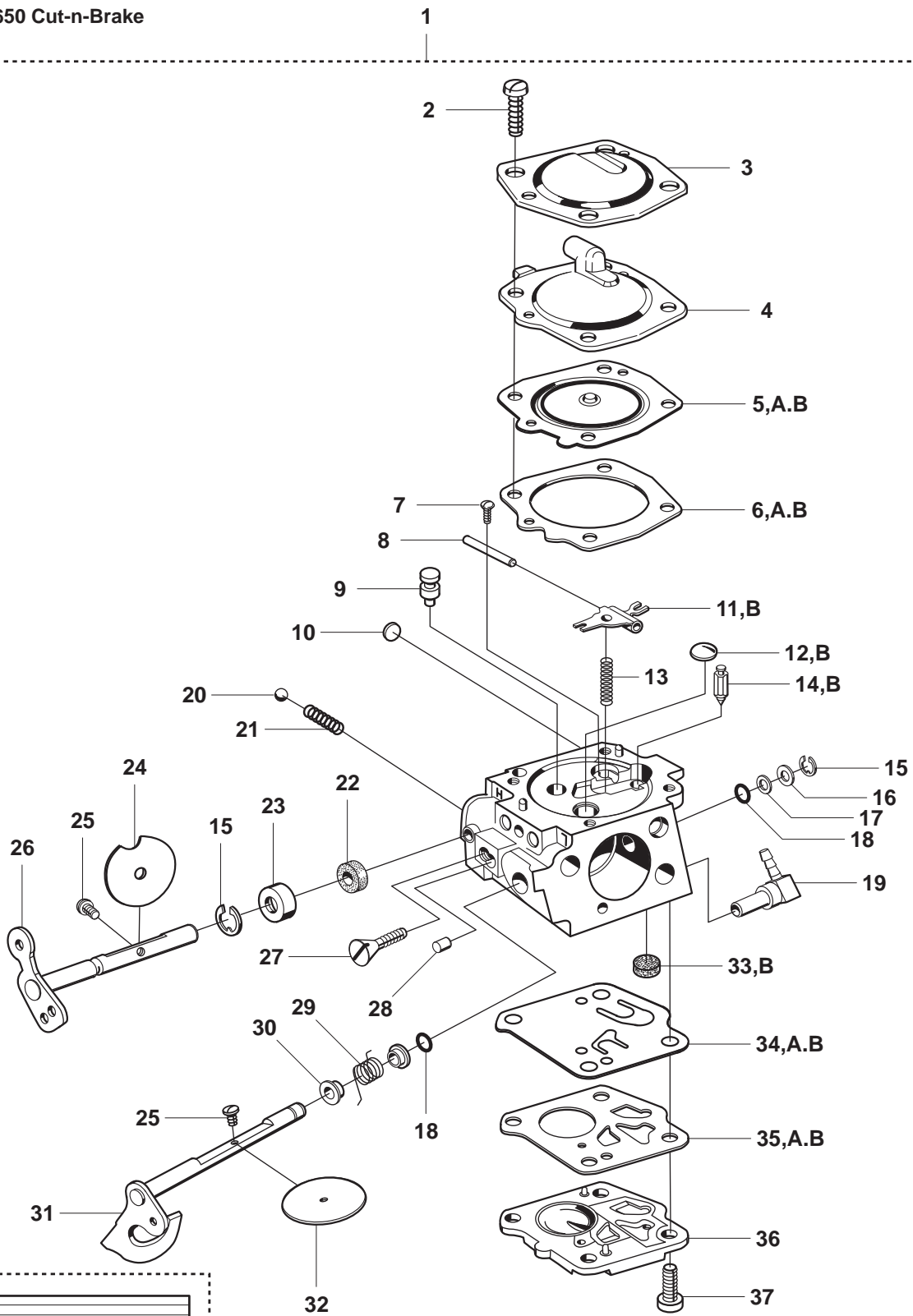
**N****K650 Cut-n-Brake**

**Page N**  
**K650 Cut-n-Break**

Pos.	Part No.	Description	Quantity	Notes
1	503 28 04-18	CARBURETTOR	1	Tillotson HS 175N. Incl. 2 - 39
2	506 27 14-01	MET.RETENTION SCREW	4	
3	506 31 61-01	DIAPHRAGM	1	
4	506 31 15-01	INSERT	1	Yellow
5	501 22 09-01	DIAPHRAGM	1	Kit 38 & 39
6	501 22 08-01	DIAPHRAGM GASKET	1	Kit 38 & 39
7	501 48 52-01	PIN RETAINING SCREW	1	
8	501 22 21-01	PIN RETAINING SCREW	1	
9	503 77 98-01	CHECKVALVE ASSY	1	
10	501 22 02-01	WELCH PLUG(SMALL)	1	
11	501 22 20-01	LEVER	1	Kit 39
12	501 22 03-01	WELCH PLUG(LARGE)	1	Kit 39
13	501 22 25-01	SPRING	1	
14	505 31 65-50	INLET NEEDLE	1	Kit 39
15	501 82 18-01	THROTTLE SH."E"RING	1	
16	503 65 31-01	THROTTLE SH.WASHER	1	
17	503 65 30-01	WASHER	1	
18	505 31 64-95	THROTTLE SH.QUADRING	1	
19	503 53 40-01	CONNECTOR ELBOW	1	
20	501 22 04-01	CHOKE FRICTION BALL	1	
21	501 22 05-01	SPRING	1	
22	506 27 57-01	SEAL CHOKE SHAFT	1	
23	506 27 61-01	RETAINER	1	
24	506 23 83-01	CHOKE	1	
25	503 65 27-01	SCREW SHUTTER	1	
26	506 27 56-01	CHOKE SHAFT & LEVER	1	
27	503 57 87-01	IDLE SPEED SCREW	1	
28	503 57 86-01	SPEED SCREW RET BALL	1	
29	505 31 66-05	THROTTLE SH. SPRING	1	
30	501 42 71-01	CHOKE SHAFT SLEEVE	2	
31	505 31 66-19	THROTTLE SH.&LEVER	1	
32	505 31 61-14	THROTTLE FLAP	1	
33	503 98 82-01	SCREEN	1	
34	501 22 12-01	FUEL PUMP DIAPHRAM	1	Kit 38 & 39
35	501 22 13-01	FUEL PUMP GASKET	1	Kit 38 & 39
36	501 22 14-01	FUEL PUMP COVER	1	
37	501 22 15-01	SCREW	4	
38	506 32 12-01	REPAIR PARTS KIT	1	
39	501 49 48-02	DIAPHRAGM SET	1	

**P** K650 Cut-n-Brake  
Accessories  
Zubehöre  
Accessoires  
Accesorios  
Tillbehör

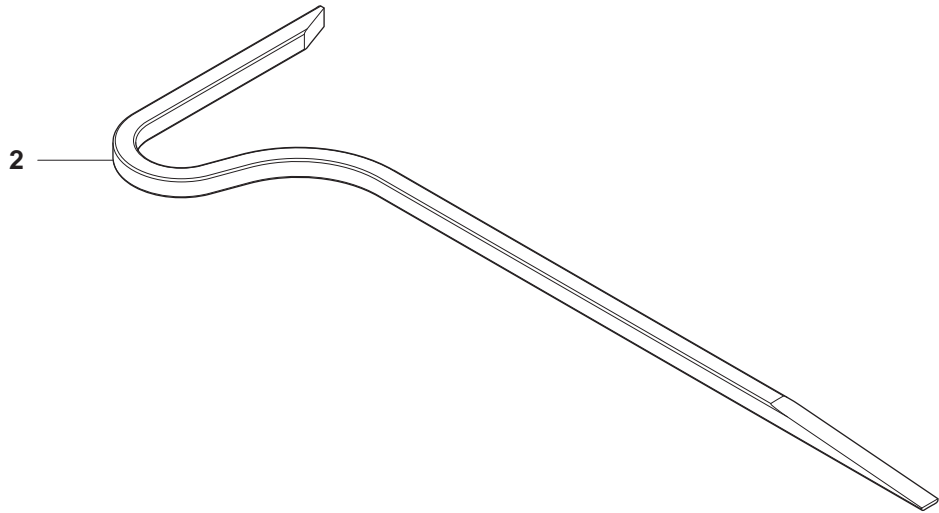
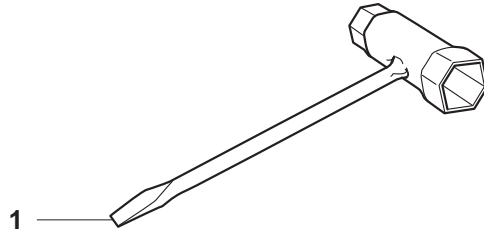

3

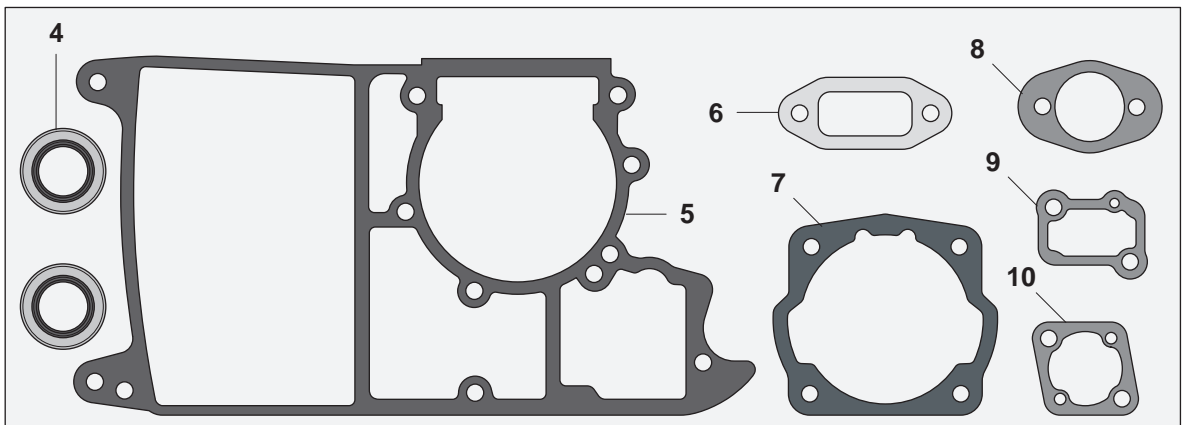

**Page P**

**K650 Cut-n-Break**

<b>Pos.</b>	<b>Part No.</b>	<b>Description</b>	<b>Quantity</b>	<b>Notes</b>
1	501 69 17-02	COMBINATION TOOL	1	NV 13 - 19
2	544 17 80-02	TOOL	1	
3	544 38 42-02	GASKET KIT	1	
4	503 26 02-04	SEALING RING	2	
5	503 44 31-01	GASKET CRANKCASE	1	
6	506 34 06-01	GASKET	1	
7	503 49 10-01	GASKET	1	
8	506 09 64-01	GASKET	1	
9	506 32 03-01	GASKET	1	
10	506 32 02-01	GASKET	1	